

# MECHANICAL FACTS AND FEATURES

TRACK ODDS AND  
DAILY DOUBLE TRACK ODDS  
CONSOLES



*Designed and Manufactured by*

**BUCKLEY MANUFACTURING CO.**

**4223 WEST LAKE STREET**

**CHICAGO, U. S. A.**

## I N D E X

Page	
1 - 3	Mechanical Features
4	Dimensions and Weight
5	To set up Machine for Operation
6	Care of Coin Chute
7	Fuses
7 - 8	Sequence of Cam Contact Switches
9	Instructions for Removing: Payout Mechanisms Odds Changer Spinner Daily Double Flasher Unit
10-11	Suggestions and Instructions on the Various Service Calls: Care of Commutators If Machine fails to Start To check failure of lights
11-12-13	To check failure of Payout Unit
14	To check failure of Odds Changer and Spinner

## PARTS BOARDS ILLUSTRATIONS

### PLATE

- # 1 - Mechanism Board Assembly  
Daily Double Flasher  
Check Separator Parts
- # 2 - Coin Head Parts
- # 3 - Spinner Unit Parts
- # 4 - Payout Unit Parts
- # 5 - Daily Double Jackpot Parts  
Odds Changer Parts
- # 6 - Cabinet Top Parts
- # 7 - Cabinet Assembly Parts

## WIRING CIRCUITS

- Circuit # 1 - Odds Changer Lights
- # 2 - Spinner Lights
- # 3 - Panel Lights
- # 4 - Daily Double Lights
- # 5 - Transformer
- # 6 - Master Relay Coil (Closing)
- # 7 - Master Relay Coil (Holding)
- # 8 - Motor and Motor Brake Coil (Starting)
- # 9 - Motor and Motor Brake Coil (Running)
- #10 - Spinner Clutch Coil
- #11 - Spinner Brake Coil
- #12 - Flasher Motor and Brake Coil
- #13 - Odds Changer Coil
- #14 - Payout Reset Coil
- #15 - Payout Relay Coil
- #16 - Payout Relay Coil
- #17 - Payout Coil
- #18 - Daily Double Payout Coil
- #19 - Motor Variator and Resistor
- #20 - Coin Head Locking Coil

TO THE OPERATOR:

1941 model Track Odds and Daily Double Track Odds are custom built by thoroughly trained and expert coin-machine craftsmen.

Please do not confuse these special built consoles with other types of mass production machines which are designed and built to give only limited service.

Buckley Track Odds and Daily Double Track Odds will stay on location year in and year out. Only the best of materials and workmanship are put into these consoles.

You should install Track Odds and Daily Double Track Odds in your best locations. The first few weeks of play will convince you that no other coin-operated machine can compare with Track Odds and Daily Double Track Odds from the standpoint of earnings. The earnings will be consistent month after month. No longer will it be necessary to switch machines every month or two. When you buy Buckley consoles you make a profitable and permanent investment.

Many out-of-the-ordinary and exclusive features are incorporated in the design and manufacture of these custom built consoles. The price of the machine includes these exclusive features -- there are no additional charges -- we give you the best equipment available.

TWO POPULAR MODELS

TRACK ODDS ( STANDARD MODEL ) WITH PAY OUT  
of 2, 4, 10, 16, and 30.

DAILY DOUBLE TRACK ODDS, with regular payout of 2, 4, 10, 16, and 30, plus--daily double payout up to \$25.00 tops. Daily Double feature has flasher dial, with auxiliary payout for added purse Daily Double checks.

TOP GLASS (An exclusive feature).

The top glass used in Buckley's console machines is something new and different and is presented for the first time in the coin machine industry. It is called "TUF-FLEX", a newly patented, tempered plate glass that offers super-strength and perfect clearness. While it is not claimed to be unbreakable, it is a proven fact that Tuf-Flex will stand at least 100 times more abuse than the finest grade plate glass of the same thickness. For this reason, it adapts itself ideally for use in a machine of the console type. TUF-FLEX cannot be cut or drilled with any known instrument or tool and therefore, offers maximum protection.

Each top is attractively and brilliantly laid out with color schemes perfectly suited for the various types of games offered.

#### STEEL CABINETS (Drill-proof)

Newly designed, modernistic, all steel, electrically welded cabinets -- finished in a manner comparable to the most modern and finest automobile bodies. The use of steel cabinets in coin-operated machines is a forward step in the industry's progress.

Hardened steel plate interlining definitely eliminates the possibility of drilling the cabinet to manipulate the mechanism. This positive drill-proof protection is standard equipment -- no extra charge.

As an added protection a special guard rail is provided around the spinner arm. This guard rail is of drill-proof Swedish steel.

All cabinets are equipped with heavy, modernistic, chrome plated feet, adjustable to assure level installation. Ample space is provided for the use of weights and each cabinet has been scientifically constructed to provide proper ventilation so as to eliminate any possibility of the mechanism over-heating.

#### MULTIPLE COIN CHUTE

The coin head used is of the multiple seven slot type -- our own special design and manufacture -- carefully tested in our factory under actual operating conditions for at least 100 plays. We recommend it as being the only multiple coin head available that will operate with maximum efficiency. Chart proof--gyp proof--manipulation proof. Easy to service, if necessary. Any separate slot can be played or all seven slots can be played or any combination of the seven slots can be played at one time.

The last four coins played in each slot are clearly visible, thus practically eliminating the slug nuisance. The handle is provided with a clutch to prevent breakage from violent usage.

Coin heads on Buckley's consoles are equipped with a special design of locking mechanism. When the machine is played, this locking mechanism will automatically lock the coin head. This will prevent the coin head being operated until the cycle of the machine is completed.

#### PAYOUT UNIT

Buckley console machines are equipped with the famous Buckley PAYMASTER unit, the one which has been so sensation-

ally popular on more than 10,000 automatic payout machines and which has been generally approved by qualified engineers and operators as representing the finest and most compact piece of automatic payout equipment ever developed. Extremely rapid in its action, positive in its payouts--the PAYMASTER is designed to eject one coin at a time--any variation in the thickness of coins will not effect the operation--it will positively pay out the correct amount of coins every time.

#### ODDS CHANGER

To add greater player appeal and to further eliminate the charting practice so commonly followed on all other machines of the spinner type, we have developed and use our own exclusive changing odds reel, controlled by a special "Variator" of our own exclusive design.

Every time machine is played the odds changing drum is spun three times--each spin making from one to two revolutions. Drum is equipped with 24 stops. Odds have been carefully calculated to fascinate the players and hold their interest.

#### VARIATOR

The Variator used in Buckley Console machines consists of mechanically operated cam switch mechanism. This cam operates two sets of switches. #1 set of switches governs the speed variations of the odds changer. #2 set of switches governs the speed variations of the Spinner. To realize the full benefits of this Variator, the knurled drive wheel must be in constant contact with #3 cam. (See sketch Variator).

#### SPINNER

The spinner used in Track Odds and Daily Double Track Odds is also of our own design. It incorporates two outstanding principles that insure perfect operation.

First--it is what we term "Free-Wheeling." By this, we mean it operates in a manner directly opposite of the usual spinner device. The power of the motor rotating the spinner arm is automatically thrown off as soon as the spinner arm reaches a certain speed, from this point, and until the spinner comes to a definite stop, the spinner revolves under its own momentum on roller bearings which require no lubrication.

Second--the speed of the motor which sets the spinner in motion is variable and is controlled by our own designed speed Variator.

As a result, of the use of the "Free-Wheeling" and speed Variator principles, we have eliminated any possibility of the players charting the spinner. This is another exclusive feature found only in Buckley consoles.

## POWER TRANSFORMER

Buckley custom-built consoles are equipped with heavy-duty-transformers which are designed to automatically compensate for the average fluctuation in current supply. The regular current of 110 volts, 60 cycles, is reduced as follows:

- 6-8 volts for the light circuit.
- 24 volts for the payout circuit.
- 24 volts for the spinner circuit.
- 24 volts for the odds changer circuit.

## WEIGHTS and MEASUREMENTS

### TRACK ODDS

206 pounds

Net Weight

Gross Weight

295 pounds

(Packed for shipment)

Dimension of Cabinet: 19 in. x 40 in. x 43½" high

Dimension of Shipping crate: 22½" x 44" x 48" high

### DAILY DOUBLE TRACK ODDS

216 pounds

304 pounds

BUCKLEY  
TRACK-ODDS  
AND  
DAILY DOUBLE TRACK ODDS

-o-o-o

I N S T R U C T I O N S

(These instructions and circuit diagrams apply only to machines with serial numbers 12,000 and over, built since April 1941).

TO SET UP MACHINE FOR OPERATION:

Each machine is provided with four heavy, modernistic, chrome plated feet, adjustable to assure firm installation. These feet are packed in a corrugated paper box, packed with machine. Holes are provided in the base of the machine for fastening these legs.

BE SURE that the available current is 110 volts 60 cycle alternating current. If machine is plugged into different current it may cause serious damage to electrical parts.

TO LIFT TOP GLASS--turn lock (located immediately under coin top housing at the rear of machine) and pull out latch rod.

Check all plugs to be sure that no connections have been loosened during shipment. See that all fuses are in place. Then--load the payout tube--we recommend that tube be completely filled (180 coins or checks). If your machine is equipped with Daily Double feature, load the Daily Double checks (packed in cloth bag in cash box), in the auxiliary payout. We recommend that these checks be placed in Daily Double auxiliary payout, in the following order:

5¢ PLAY MACHINES

4 checks	marked	3.50 each	bottom
1 check	"	5.00	
4 checks	"	3.50	
1 check	"	10.00	
4 checks	"	3.50	
1 check	"	5.00	tube
6 checks	"	3.50	
1 check	"	23.50	
8 checks	"	3.50	top

## 25¢ PLAY MACHINES

### SUGGESTED ARRANGEMENT OF JACKPOT TOKENS IN QUARTER DAILY DOUBLE TRACK ODDS

We suggest that the jackpot tokens be inserted in the Daily Double payout in the following manner:

4	tokens	marked	70	bottom
1	"	"	80	
4	"	"	70	
1	"	"	100	
4	"	"	70	tube
1	"	"	80	
6	"	"	70	
1	"	"	300	
8	"	"	70	top

In following this arrangement, the 4 tokens with the value of 70 quarters will be placed at the bottom of the payout tube and will follow as outlined above.

Of course, any arrangement desired by the operator can be used but we recommend that the tokens be placed in the Daily Double payout as outlined above as this method has proven satisfactory in the operation of many quarter play machines.

When loading payout tube, be sure that the first few coins or checks are flat in payout tube base. Test payout and if O. K. fill up the payout tube.

BE SURE top glass latch is replaced and locked, and cash box door is securely locked.

For best operation be sure that coin slides in coin chute are cleaned regularly. The following information will give you a better understanding of the operation and adjustments recommended from time to time to assure complete satisfaction and uninterrupted operation. Study these instructions before attempting to make any adjustments.

#### COIN CHUTE

The coin chute housing is one solid assemble. In order to remove the housing, lift up playing field glass, push out pins (marked red) the ends of which appear in the two lower corners, underneath the housing casting. Any small tool is suitable for this purpose. After pins have been removed, housing can be lifted from mechanism. When replacing coin chute housing, hold handle at its farthest back position to insure positive engagement of actuating part.

#### COIN CHUTE CONTACT SWITCHES

There are seven sets of triple contact switches located in the back of the coin chute mechanism. These switches control the

lights in the seven (7) panels located in the upper end of the glass top, payout mechanism and also the switch for motor circuit, for example: When a coin is played in any slot, the triple switch in the back of that particular slot is closed. One of these switches illuminates the light-up panel corresponding to the slot in which the coin has been played. The other switch closes the circuit which leads to the corresponding contact on the spinner commutator. If the spinner stops on this number, the circuit is completed and the machine pays off. The third switch closes the motor circuit.

#### MOTOR STARTING SWITCHES

There are three contact switches located in the cabinet under the coin chute. The bottom switch "A" is the master relay closing switch. The center switch "B" is the master relay holding switch. The top switch "C" is the motor starting switch.

The bottom switch "A" is closed only for an instant when a coin is played. At all other times this switch is open. IMPORTANT: If the bottom switch "A" is closed when it should be open, the machine will run continuously without the insertion of a coin.

The center switch "B" is closed when the bottom switch "A" is closed. It then opens for an instant and again closes when the top switch "C" is closed.

The top switch "C" is open for an instant when a coin is played, but at all other times it is closed. IMPORTANT: If the top switch "C" is open when it should be closed the motor will not start.

#### FUSES

- #1 - Main Fuse - 110 Volts - 5 Amp.
- #2 - Payout Fuse - 24 Volts - 10 Amp.
- #3 - Odds Changer)  
and Spinner) - 24 Volts - 10 Amp.  
Jackpot and Flasher on )  
Daily Double Master Relay)  
and Payout Relay).
- #4 - Light Fuse - 6 Volts - 20 Amp.

#### SEQUENCE OF CAM CONTACT SWITCHES

- #1 cam switch runs the motor. This switch is open at the beginning of the cycle.
- #2 cam switch closes the master relay. This switch is closed at the beginning of the cycle.
- #3 cam switch shuts off the master relay when its cycle is completed. This switch is closed at the beginning of the cycle.

- #4 cam switch energizes the coil which engages clutch on the spinner, causing arm to revolve. This switch is open at the beginning of the cycle.
- #5 cam switch energizes the coil which releases the brake on the spinner gear and again applies this brake when the switch contact opens near the end of its cycle. This switch is open at the beginning of the cycle.
- #6 cam switch energizes the coil which spins the odds changer. This switch is open at the beginning of the cycle.
- #7 cam switch energizes the small coil located in the payout mechanism. When this coil is energized the commutator disc (or copper sector V) is released, bringing it back to its starting position. This switch is open at the beginning of the cycle.
- #8 cam switch energizes the payout relay coil which completes the #15 payout circuit, allowing the payoff mechanism to complete the pay-off designated on the odds changer. This switch is open at the beginning of the cycle.
- #9 cam switch (installed only on machines equipped with daily double auxiliary payout). This switch operates daily double flasher motor. This switch is open at the beginning of the cycle.

INSTRUCTIONS FOR REMOVING  
PAYOUT MECHANISM, ODDS CHANGER, SPINNER  
AND DAILY DOUBLE FLASHER UNITS

**TO REMOVE PAYOUT MECHANISM:**

Pull out 2 male plugs fastened on top of payout mechanism. Then remove red screws on payout base. Loosen four green screws on steel parts fastened to payout tube, slide each of these steel parts down about one inch (1") then turn mechanism slightly and lift out of cabinet.

When mechanism is replaced, be sure to line it up on the base so that the coins will properly feed into the tube. Also be sure to set steel parts on tube back in their original location, and tighten 4 green screws firmly.

**TO REMOVE ODDS CHANGER UNIT:**

Pull out 3 male plugs. Remove four nuts fastening legs of odds changer. Then lift odds changer from the cabinet.

When replacing the odds changer be sure to locate it in its original position.

**TO REMOVE SPINNER UNIT:**

Pull 2 male plugs. Then remove the three nuts fastening the spinner to the board and lift spinner from cabinet.

When replacing spinner, be sure it is located in exact position as originally installed. After unit is fastened in cabinet, check to see that spinner arm does not drag on spinner guard; also, that light appears squarely under colored number panel of top glass.

**TO REMOVE DAILY DOUBLE FLASHER UNIT:**

Pull out 2 male plugs. Take out 2 wood screws and lift Flasher Unit out of cabinet.

## SUGGESTIONS AND INSTRUCTIONS

### ON THE VARIOUS SERVICE CALLS

#### CARE OF COMMUTATORS:

There are two (2) commutators. They are located on the spinner and odds changer. **IMPORTANT:** Keep these points lubricated, using 3-in-one oil. The lubrication of these points will keep the contacts clean and prevent corrosion.

#### IF MACHINE FAILS TO START WHEN COIN IS PLAYED:

1. See that the power cord is plugged in.
2. Inspect fuse #1.
3. Trace circuit #5 and circuit #9.
4. See that starting switch rod is working freely and returning to its original starting position.
5. When handle is held down after putting coin in slot, master relay should be closed. If it is not closed check circuit #7; also check relay closing switch on circuit #6.
6. If master relay is closed when handle is down, but opens when handle is returned, check circuit #7, especially relay holding switch. Also check master relay switch "A", (in circuit #8) which should also be closed when handle has been returned.
7. If circuits #5 and #9 are O. K.; check circuit #6, especially motor starting switch. Also check master relay switch "B" (in circuit #7). Both of these switches should be closed when handle has been returned.
8. Check switches in coin chute. These switches should be closed when coins are located in front of switch plungers.

### L I G H T S

All lights are 6-8 volts, bayonet type. The larger lights are type #81, and the smaller lights, type #51. All light bulbs are in duplicate (except small bulbs in Daily Double Flasher). The accidental burning out of one bulb will not result in an unnecessary service call.

#### TO CHECK FAILURE OF LIGHTING CIRCUITS

##### A. IF ALL LIGHTS FAIL TO LIGHT:

1. Inspect fuse #4.

##### B. IF PANEL LIGHTS FOR A PARTICULAR NUMBER FAIL:

1. See that coin chute switch is closed.
2. Inspect bulbs and socket connections.
3. Check circuit #3, and be sure that ground connections are tight.

C. IF ALL PANEL LIGHTS FAIL:

1. Check action of switch carrier plate on coin chute.
2. Check action of pump, controlling switch carrier plate.
3. Check circuit #3, and be sure that ground connection is tight.

D. IF A PARTICULAR LIGHT ILLUMINATES WHEN A COIN IS NOT PLAYED:

1. See that the light contact switch in the coin chute is not closed when there is no coin in the corresponding slot.

E. IF SPINNER LIGHTS FAIL:

1. Inspect bulbs and socket connections.
2. Check fuse #4.
3. Check spinner ring brushes "A", in circuit #2.
4. Check circuit #2, and be sure ground connection is tight.

F. IF ODDS CHANGER LIGHTS FAIL:

1. Inspect bulbs and sockets.
2. Check fuse #4.
3. Check circuit #1, and be sure ground connection is tight.

TO CHECK FAILURE OF PAYOUT UNIT

A. IF MACHINE DOES NOT PAY OUT ON ANY PLAYED SLOT:

(This is usually due to payout coil failing to operate)

1. Check Fuse #2.
2. Check plugs #1, #2, #3, #5, and #6. They should be pushed down firmly in the female sockets.
3. Check alignment of odds changer brushes with odds changer commutator points.
4. Check coin chute switches. They should be closed when coins are located in front of the switch plungers.
5. Check payout unit oscillating switch for loose connections or failure to make proper contacts.
6. Check payout unit connecting rod, which is fastened to shaft in large payout coil. If this rod is broken, coil will energize but will not pull coin ejector slide forward to eject the coins.
7. Check spinner commutator brush, be sure that it is pressing against all the buttons to make positive contact.
8. Check circuit #15.

B. IF MACHINE DOES NOT PAY OUT BUT PAYOUT MECHANISM MAKES A CLICKING NOISE:

1. This trouble is caused by coins being turned in the payout tube. There is a hole drilled in the cabinet, underneath the payout tube; insert small screw driver in this hole and loosen coin jam. If it is impossible to settle coins into their proper position, remove the payout tube and

straighten coins in payout base. When replacing payout tube be sure that the two spring wires in the payout base are located in their proper places.

C. IF UNIT PAYS OUT ONLY ONE COIN OR FAILS COMPLETELY:

1. Check return action of payout unit Sector V. Be sure that Sector V does not bind when it returns to starting position.
2. Check plunger contacts in circuits #15 and #16 and be sure they are pressing firmly against the Sector V.
3. Check circuit #14 - payout reset coil and contact on #7 cam switch.

D. IF UNIT PAYS ONLY ONE TO FOUR COINS WHEN IT SHOULD PAY MORE:

1. Check payout relay coil in circuit #16. This coil should remain closed until payout is completed. If this coil fails to remain closed for duration of payout, proceed as follows:
2. Clean contact sector V on payout unit.
3. Check relay coil switch "B" and cam switch #8 in circuits #15 and #16.
4. If switches are O. K., check circuit #16 through Spinner.
5. Check circuit #14 to see that payout unit resets.
6. If payout coil fails to return to starting position, trouble may be in the condenser. (Condenser is the metal box with two porcelain plugs and mounted on payout mechanism.) To prove condenser, disconnect the wires leading to condenser. If payout unit operates with condenser disconnected, it shows condenser is faulty, and should be replaced with a new one.

E. IF PAYOUT FAILS WHEN ONE CERTAIN SLOT IS PLAYED:

(All other slots pay out correctly)

1. Check coin chute switches in slot that is giving trouble.
2. Check Spinner commutator contact.
3. Check odds changer commutator contacts. (#7 slot has 2 contacts on odds changer).
4. Trace circuit #16 through Spinner, then through coin chute and through odds changer.

F. IF UNIT FAILS TO PAY ON A CERTAIN COMBINATION:

(2, 4, 10, 16 or 30)

1. Check odds changer collector ring contact.
2. Check payout unit brush contacts.
3. Check circuit #15 through odds changer, payout unit and through #3 and #8 cam switches.

G. IF UNIT PAYS OUT MORE THAN THE AMOUNT SHOWN ON ODDS CHANGER:

1. Check springs on actuating and retaining pawl of payout ratchet.

2. Check retaining pawl for proper clearance, between the retaining pawl and payout ratchet notch. This checking should be done when the payout ratchet is in reset position and the square block on ratchet is resting on set screw painted red. Make adjustment as follows:  
Move retaining pawl out of the ratchet notch, then let it in slowly to engage. If the pawl is not free to engage into the ratchet notch, turn set screw painted red in, until pawl is engaging freely.
3. Check copper sector V - fastened together with fibre disc to main payout unit shaft, by 3/16" steel hexagon nut, as follows:

Reset payout unit to starting position, then advance payout copper sector V - two notches on the payout ratchet, then check two plungers marked by No. 2. These two plungers should clear the copper segment V - about 1/32" and rest only on fibre disc. If these two plungers do not have a clearance of 1/32" from the copper sector V -, readjust the copper sector V - as follows:

Loosen 3/16" steel hexagon nut, turn copper segment V - together with the fibre disc to left, until the two plungers clear the copper sector V - by 1/32", then tighten steel nut securely.

This adjustment is very important and care should be taken not to advance the copper sector V- more than 1/32".

If this adjustment is made and the machine pays out correctly on two plungers marked number 2, check payout on plunger marked number 30. If the machine pays out one or two coins short, make following adjustment:

Reset payout Unit to starting position, advance payout copper sector V - 30 notches on payout ratchet. Check one plunger marked number 30. This plunger should clear the copper sector V- about 1/32". If the clearance is greater than 1/32", most likely the machine will pay short.

Loosen 2 round head machine screws, that holds the square fibre plate to which the plungers are attached.

Shift only one end of the fibre plate (the nearest end to number 30 plunger) until plunger marked number 30 has 1/32" clearance from the copper sector V-.

Tighten two screws securely.

Improper adjustment of copper sector V- and fibre plate (plunger mounting plate) will cause the machine to pay too many or not enough coins or checks.

H. IF MACHINE PAYS OUT WHEN NO COIN IS PLAYED:

1. Check coin chute switches. These switches should be open when there is no coin in front of the switch plungers.

TO CHECK FAILURE OF ODDS CHANGER

A. IF ODDS CHANGER DRUM FAILS TO REVOLVE:

1. Check circuit #13 and be sure that #6 cam switch is making proper contact.
2. Examine fuse #3.

B. IF DRUM STOPS BETWEEN ROWS OF NUMBERS:

1. Check action of spring which returns coil shaft; if spring is weak, replace it.
2. See that drum is not dragging on coil or bakelite brush mounting.

C. IF ODDS CHANGER ADJUSTMENT HAS BECOME LOOSE OR HAS BEEN INCORRECTLY ADJUSTED:

1. To set, locate the hole drilled in the commutator opposite the #1 switch, then set the paper reel strip so that the first row (2-2-4-4-4-2-30) appears through the opening of the glass.
2. See Circuit #13 for odds changer wiring.

TO CHECK FAILURE OF SPINNER

A. SPINS ONLY A FEW TURNS:

1. Tighten brass nut on spinner coil armature to increase speed.
2. To decrease speed, loosen nut. Be sure to replace cotter pin through armature and brass nut.

Correct adjustment allows spinner to revolve from 9 to 12 revolutions.

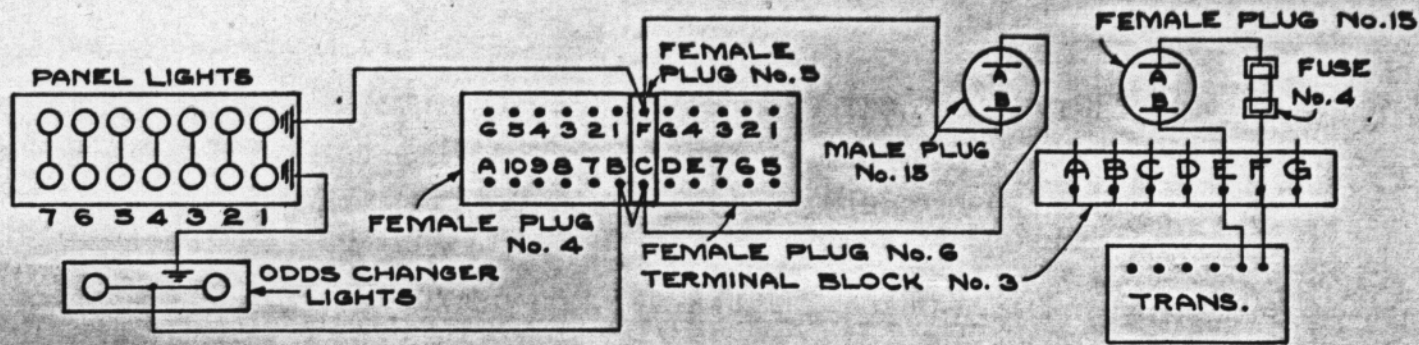

**CIRCUIT #1, ODDS CHANGER LIGHTS**  
(Illuminated Continuously)

Transformer to terminal block #3 F, Buss wire to fuse #4, white wire to Female plug #15 A, to male plug #15 A, to Female Plug #6 C, jumper to Female plug #4 B, white red black wire to odds changer lights---grounded to light mounting bar, white orange wire to panel lights mounting bar, white orange wire to Female Plug #5 F, Black wire to male plug #15 B, to female plug #15 B, Black wire to terminal block #3 E, to transformer.

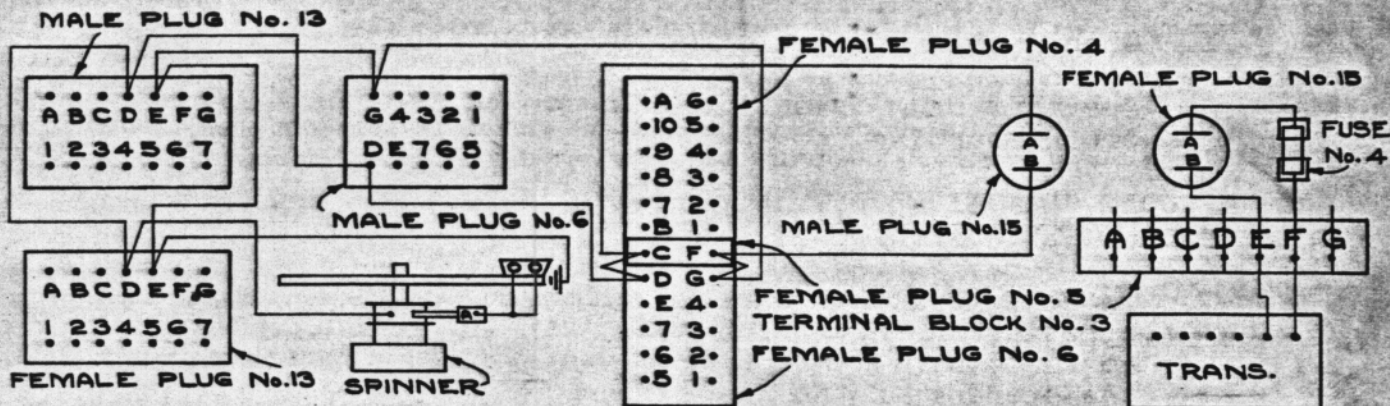

**CIRCUIT #2, SPINNER LIGHTS**  
(Illuminated Continuously)

Transformer to terminal block #3 F, Buss wire to fuse #4, white wire to Female plug #15 A, to male plug #15 A, to female plug #5 C, jumper to female plug #6 D, to male plug #6 D, white wire to male plug #13 D, to female plug #13 D, white wire to spinner ring #A, to brushes #A, white wire to spinner lights---grounded to light mounting bar, to spinner frame, white orange wire to female plug #13 E, to male plug #13 E, white orange wire to male plug #6 G, to female plug #6 G, jumper to female plug #5 F, black wire to male plug #15 B, to female plug #15 B, black wire to terminal block #3 E, to transformer.

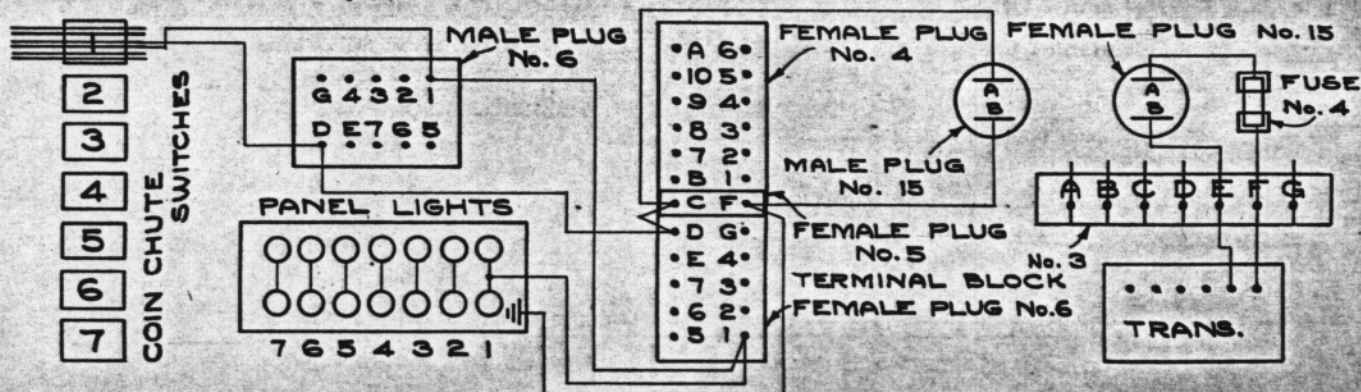

**CIRCUIT #3, PANEL LIGHTS**  
(For No. 1 Coin Slot:  
(For slots No. 2, 3, 4, 5, 6, 7, wiring is similar)

Transformer to terminal block #3 F, Buss wire to fuse #4, white wire to female plug #15 A, to male plug #15 A, to female plug #5 C, jumper to female plug #6 D, to male plug #6 D, white wire to light switch #1, white orange blue wire to male plug #6-1, to female plug #6-1, white orange blue wire to panel lights #1---grounded to lights mounting bar, white orange wire to female plug #5 F, black wire to male plug #15 B, to female plug #15 B, black wire to terminal block #3 E, to transformer.

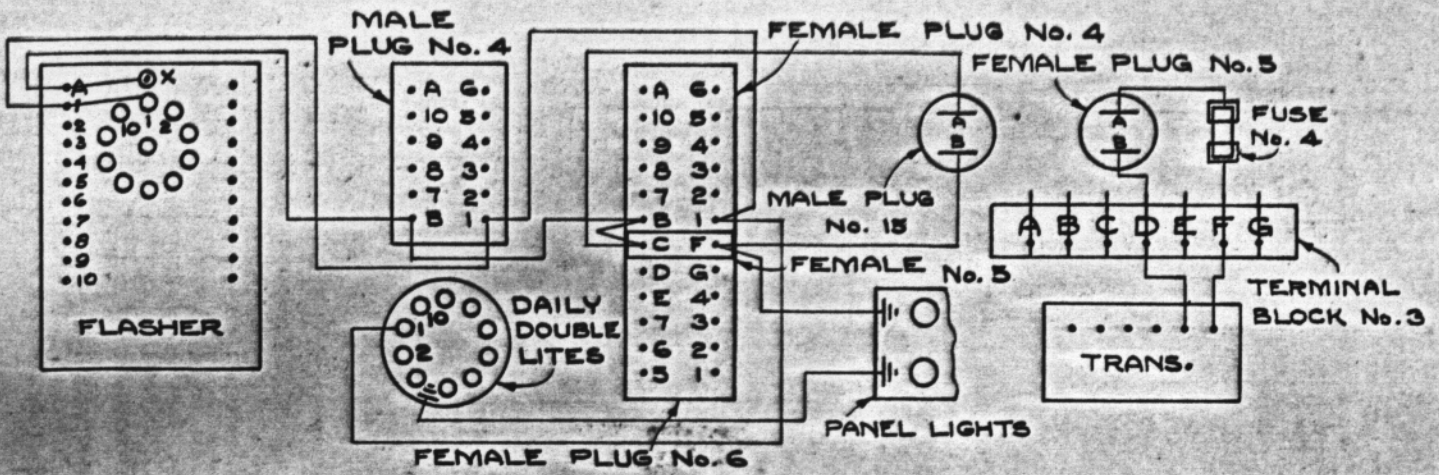

**CIRCUIT #4, DAILY DOUBLE LIGHTS**

(For #1 - Red Light)  
 (For other lights, wiring is similar)

Transformer to terminal block #3 F, Buss wire to fuse #4, white wire to female plug #15 A, to male plug #15 A, to female plug #5 C, jumper to female plug #4 B, to male plug #4 B, white wire to flasher terminal #A, white wire to plunger #X to moving plate, to moving plunger, to rivet #1, white blue wire to terminal #1, white blue wire to male plug #4 - 1, to female plug #4 - 1, white blue wire to daily double lights #1 (RED)---grounded to daily double light casting, white orange wire to female plug #5 F, black wire to male plug #15 B, to female plug #15 B, black wire to terminal block #3 E, to transformer.

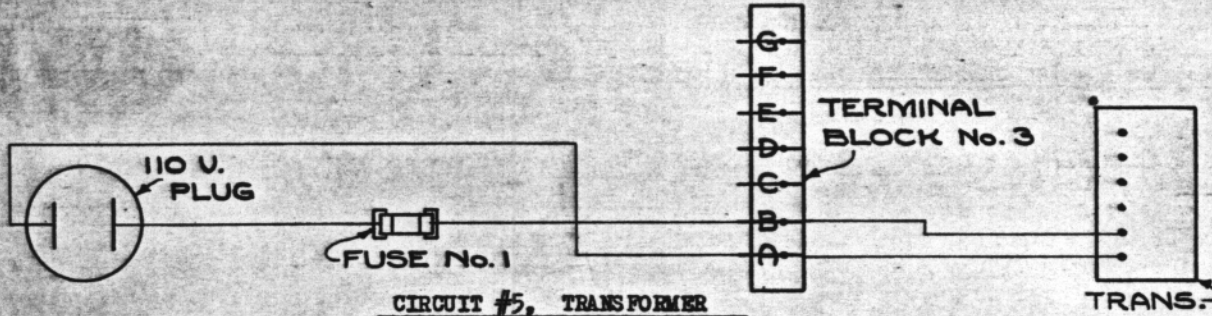

**CIRCUIT #5, TRANSFORMER**

110 Volt plug, black wire to fuse #1, black wire to terminal block #3 B, to transformer---to terminal block #3 A, black white wire to 110 volt plug.

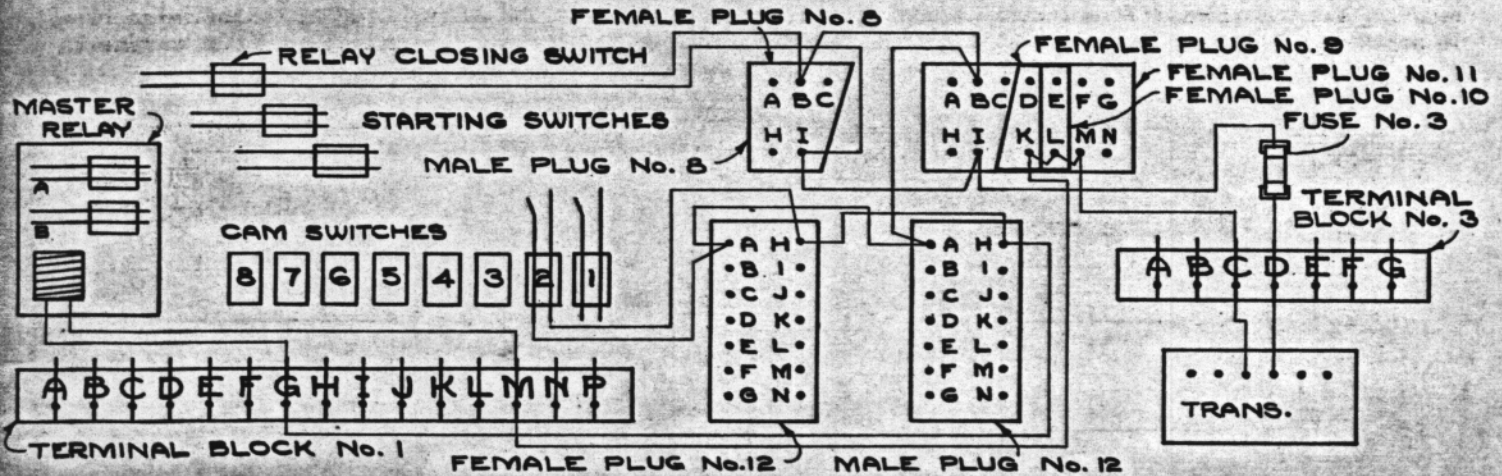

**CIRCUIT #6, MASTER RELAY COIL (CLOSING)**

The important contacts in Circuit #6 are:  
 RELAY CLOSING SWITCH & #2 CAM SWITCH.

Transformer to terminal block #3 D, yellow red wire to fuse #3, yellow red wire to female plug #8-I, to male plug #8-1, yellow red wire to relay closing switch, yellow black wire to male plug #8 B, to female plug #8 B, yellow black wire to male plug #12 A, to female plug #12 A, yellow black wire to bottom of #2 cam switch, to top of #2 cam switch, yellow black wire to female plug #12 H, to male plug #12 H, yellow black wire to terminal block #1 G, to master relay coil--- to terminal block #1 M, yellow wire to female plug #9 I, jumper to female plug #11 M, yellow wire to terminal block #3 C, to transformer.

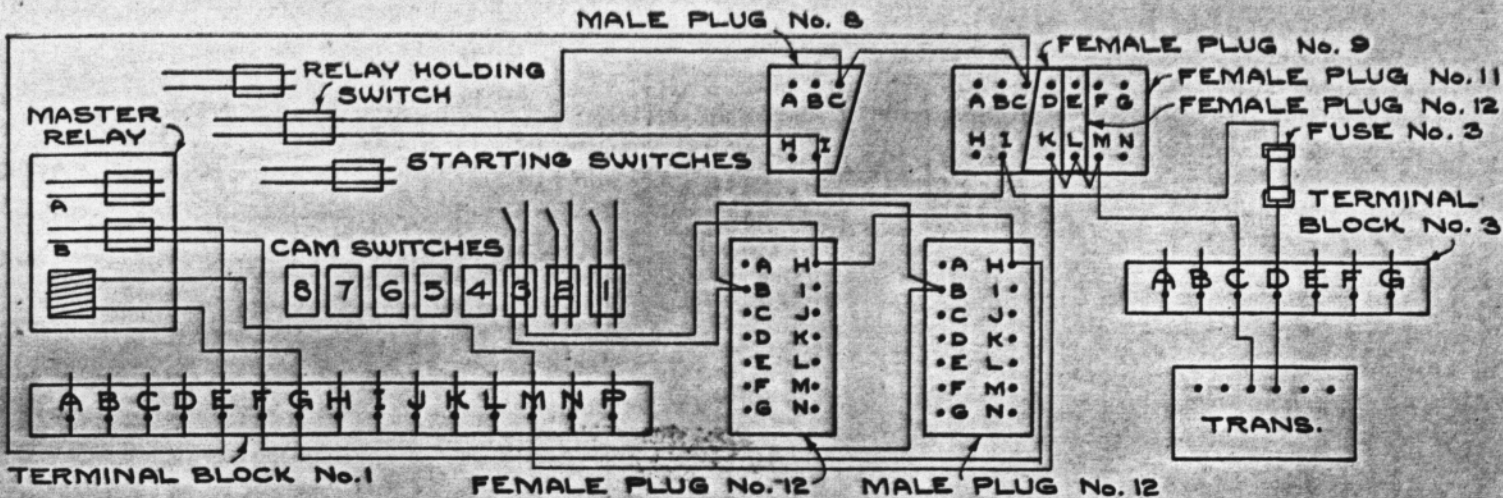

**CIRCUIT #7, MASTER RELAY COIL, (HOLDING)**

The important contacts in Circuit #7 are:  
 RELAY HOLDING SWITCH, MASTER RELAY SWITCH  
 #B & #3 CAM SWITCH.

Transformer to terminal block #3D, yellow red wire to fuse #3, yellow red wire to female plug #8-I, to male plug #8-I, yellow red wire to relay holding switch, yellow green wire to male plug #8 C, to female plug #8 C, yellow green wire to terminal block #1 E, yellow green wire to master relay switch #B, yellow green wire to terminal block #1 F, yellow green wire to male plug #12 B, to female plug #12 B, yellow green wire to bottom of #3 cam switch, to top of #3 cam switch, yellow black wire to female plug #12 H, to male plug #12 H, yellow black wire to terminal block #1 G, to master relay coil---to terminal block #1 M, yellow wire to female plug #9 K, jumper to female plug #11 M, yellow wire to terminal block #3 C, to transformer.

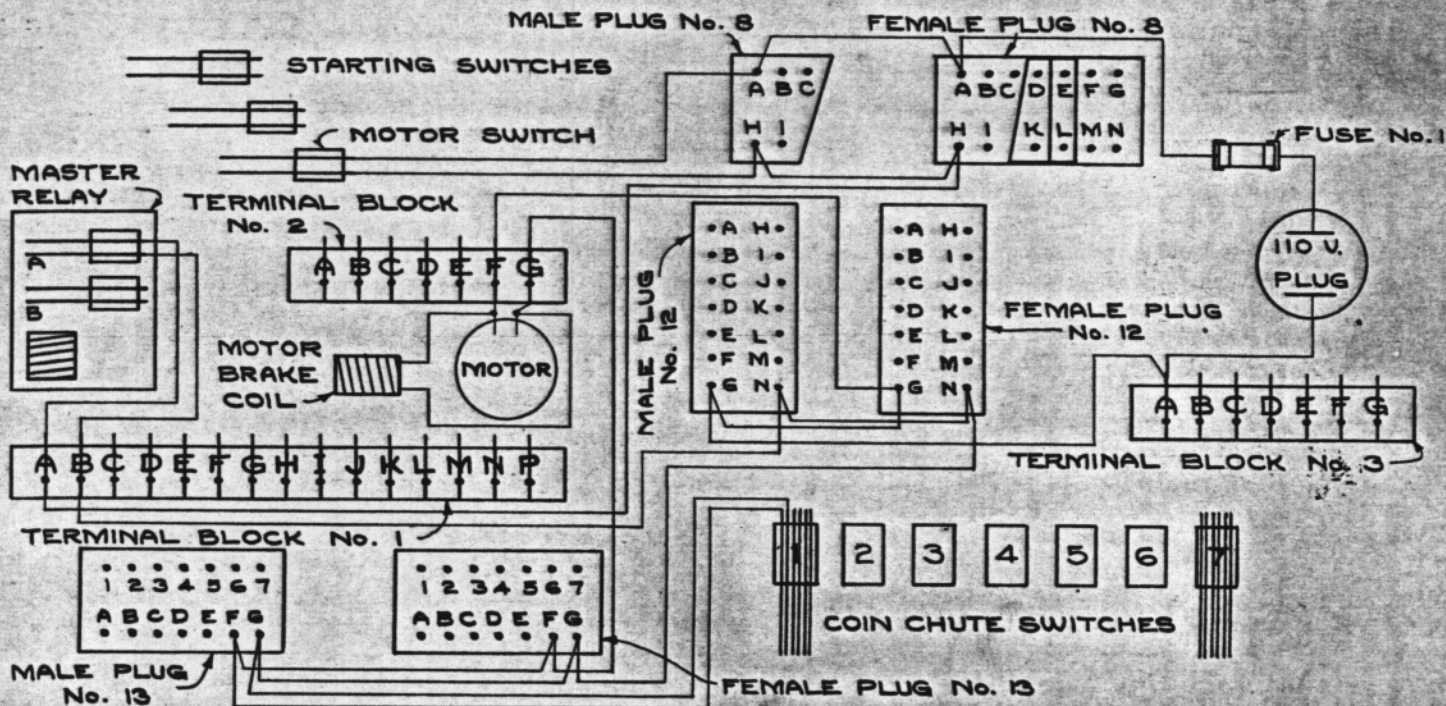

**CIRCUIT #8, MOTOR & MOTOR BRAKE COIL (STARTING)**

The important contacts in Circuit #8 are: MOTOR  
 STARTING SWITCH, MASTER RELAY SWITCH #A & COIN  
 CHUTE OUTSIDE SWITCHES.

110 volt plug, black wire to fuse #1, black wire to female plug #8 A, to male plug #8 A, black wire to motor Starting switch, black wire to male plug #8 H, to female plug #8 H, black wire to terminal block #1 A, black wire to master relay switch A, black wire to terminal block #1-B, black wire to male plug #12 N, to female plug #12 N, black wire to female plug #13 G, to male plug #13 G, black wire to coin chute outside switches, black wire to male plug #13 F, to female plug #13 F, black wire to terminal plug #2 G, to motor & motor brake coil---to terminal block #2 F, black white wire to female plug #12 G, to male plug #12 G, black white wire to terminal block #3 A, black white wire to 110 volt plug.

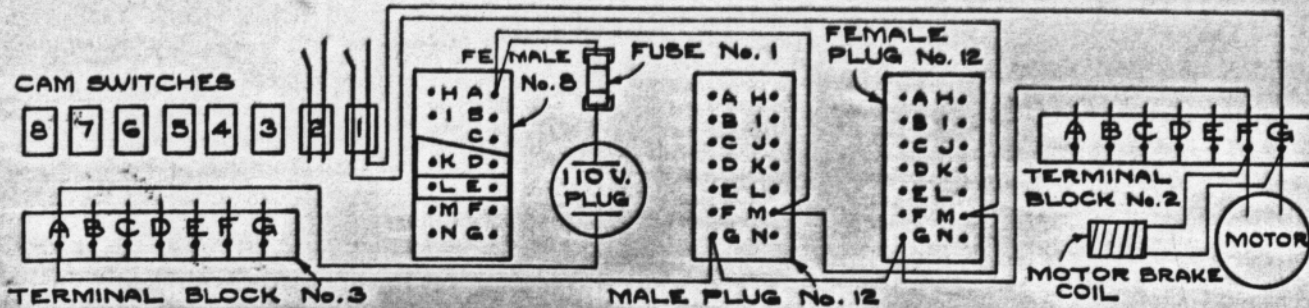

**CIRCUIT #9 MOTOR & MOTOR BRAKE COIL, (RUNNING)**  
 (Automatic cam reset if 110 v. plug is pulled before machine completes play.)

The important contact in circuit #9 is #1 CAM SWITCH

110 volt plug, black wire to fuse #1, black wire to female plug #8 A, black wire to male plug #12 M, to female plug #12 N, black wire to bottom of #1 cam switch, to top of #1 cam switch, black wire to terminal block #2 G, to motor & motor brake coil----to terminal block #2 F, black white wire to female plug #12 G, to male plug #12 O, black white wire to terminal block #3 A, black white wire to 110 volt plug.

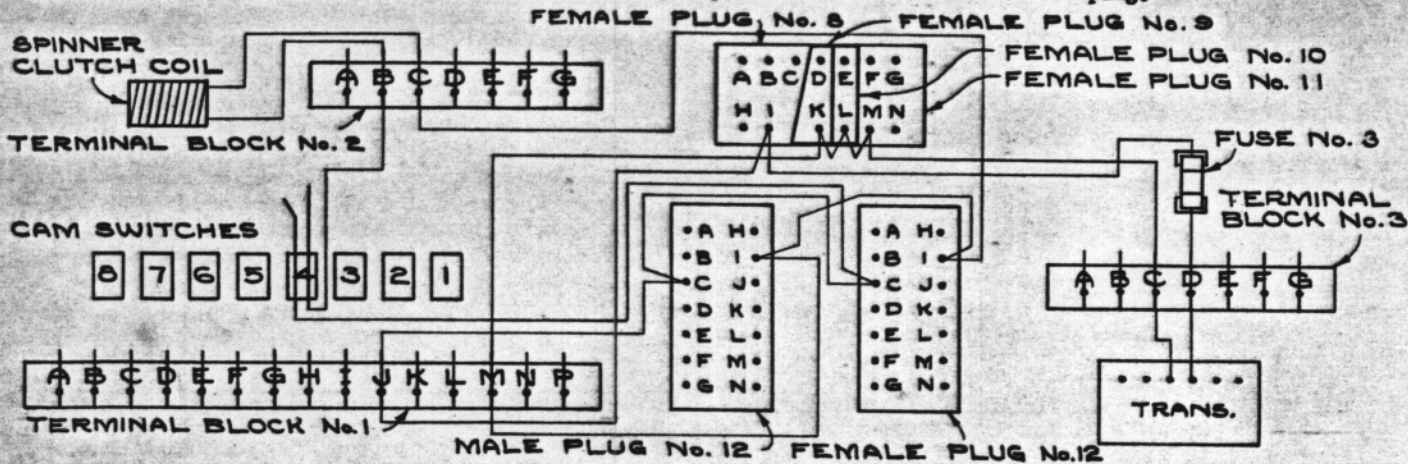

**CIRCUIT #10, SPINNER CLUTCH COIL**

The important contact in circuit #10 is: #4 CAM SWITCH

Transformer to terminal block #3 D, yellow red wire to fuse #3, yellow red wire to female plug #8-I, yellow red wire to terminal block #1 J, yellow red wire to male plug #12 C, to female plug #12 C, yellow red wire to bottom of #4 cam switch, to top of #4 cam switch, green wire to terminal block #2 B, green wire to spinner clutch coil----yellow wire to terminal block #2 C, yellow wire to female plug #12-I, to male plug #12-L, yellow wire to terminal block #1 M, yellow wire to female plug #9 K, jumper to female plug #11 M, yellow wire to terminal #3 C, to transformer.

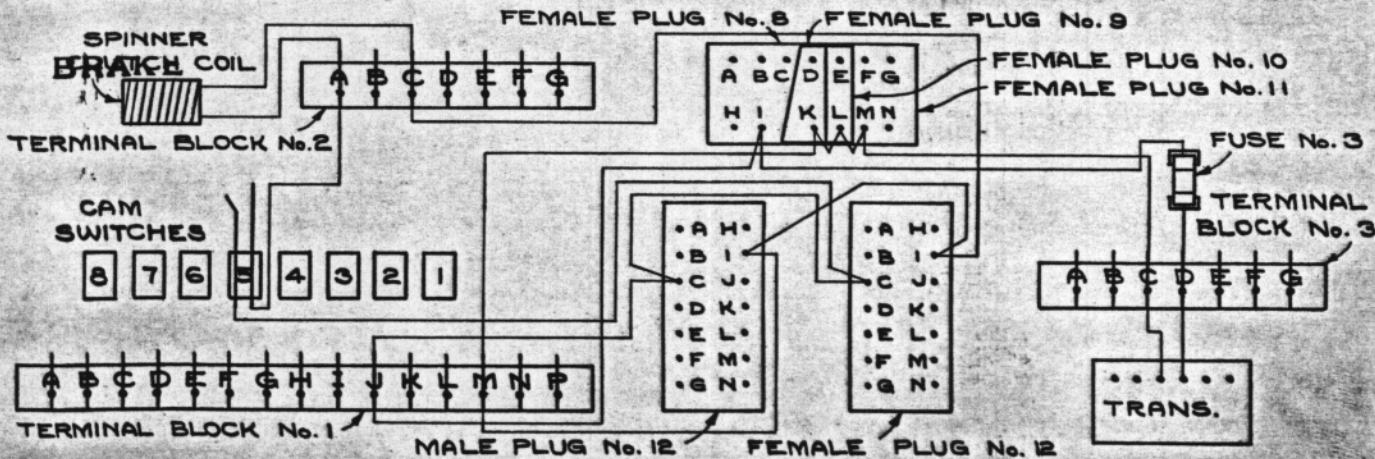

**CIRCUIT #11, SPINNER BRAKE COIL**

The important contact in Circuit #11 is: #5 CAM SWITCH.

Transformer to terminal block #3 D, yellow red wire to fuse #3, yellow red wire to female plug #8-I, yellow red wire to terminal block #1 J, yellow red wire to male plug #12 C, to female plug #12 C, yellow red wire to bottom of #5 cam switch, to top of #5 cam switch, orange white wire to terminal block #2 A, orange white wire to spinner brake coil----yellow wire to terminal block #2 C, yellow wire to female plug #12-I, to male plug #12-L, yellow wire to terminal block #1 M, yellow wire to female plug #9 K, jumper to female plug #11 M, yellow wire to terminal #3 C, to transformer.

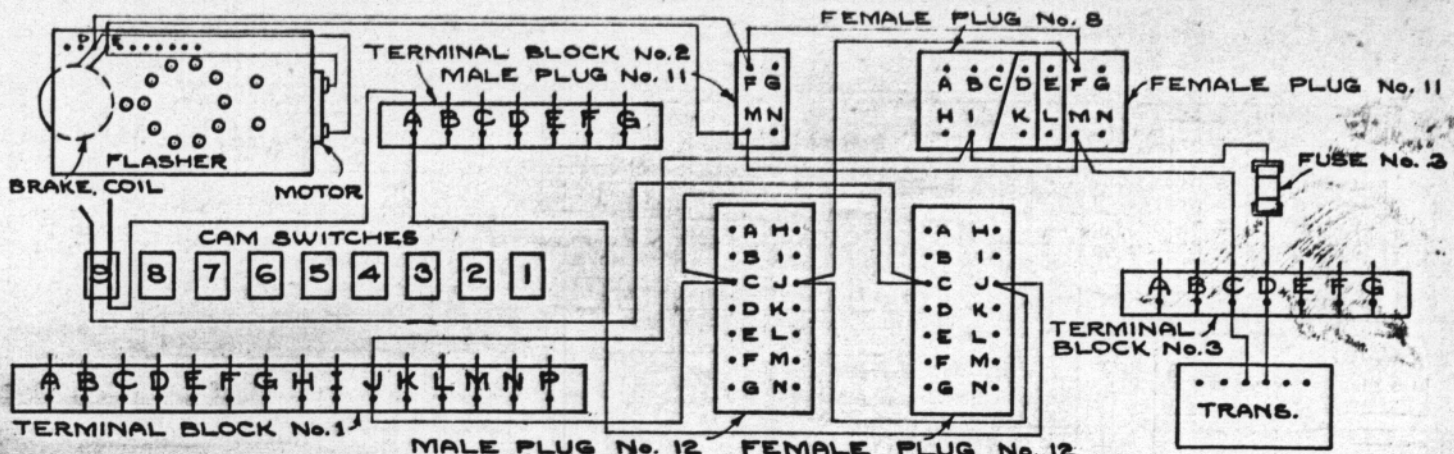

**CIRCUIT #12, FLASHER MOTOR & BRAKE COIL-Through #9 cam switch**

Transformer to terminal block #3 D, yellow red wire to fuse #3, yellow red wire to female plug #8-I, yellow red wire to terminal block #1 J, yellow red wire to male plug #12 C, to female plug #12 C, yellow red wire to bottom of #9 cam switch, to top of #9 cam switch, orange white wire to terminal block #2 A, orange white wire to female plug #12 J, to male plug #12 J, orange white wire to female plug #11 F, to male plug #11 F, orange white wire to terminal #D, orange white wire to flasher motor & brake coil---yellow wire to terminal #E, yellow wire to male plug #11 M, to female plug #11 M, yellow wire to terminal block #3 C to transformer.

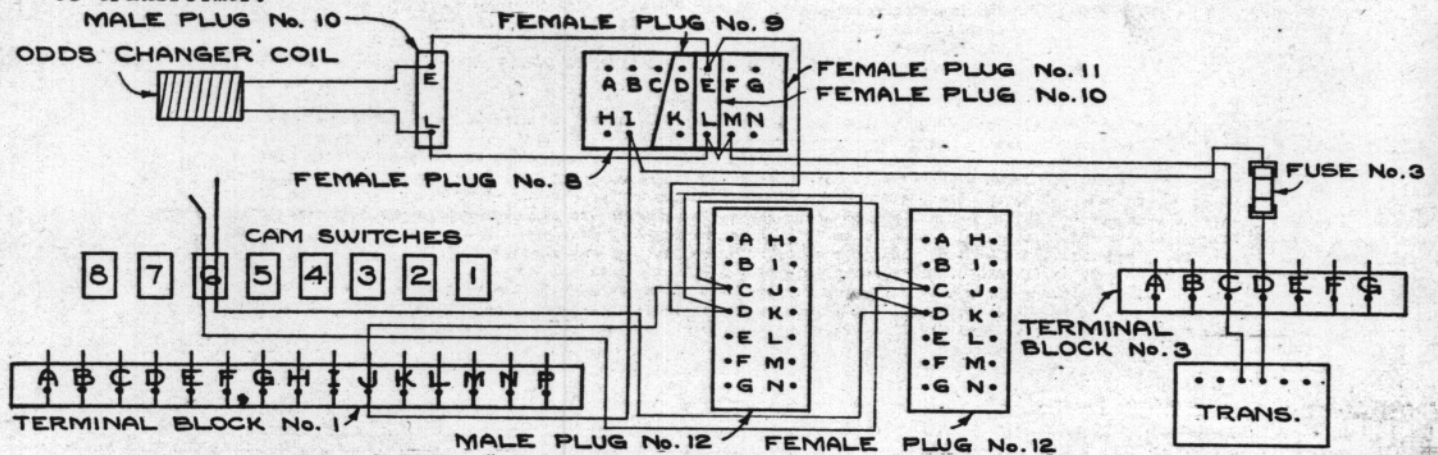

**CIRCUIT #13, ODDS CHANGER COIL-Through #6 cam switch**

Transformer to terminal block #3 D, yellow red wire to fuse #3, yellow red wire to female plug #8-I, yellow red wire to terminal block #1 J, yellow red wire to male plug #12 C, to female plug #12 C, yellow red wire to bottom of #6 cam switch, to top of #6 cam switch, orange wire to female plug #12 D, to male plug #12 D, orange wire to female plug #10 E, to male plug #10 E, orange wire to odds changer coil---yellow wire to male plug #10 L, to female plug #10 L, jumper to female plug #11 M, yellow wire to terminal block #3 C, to transformer.

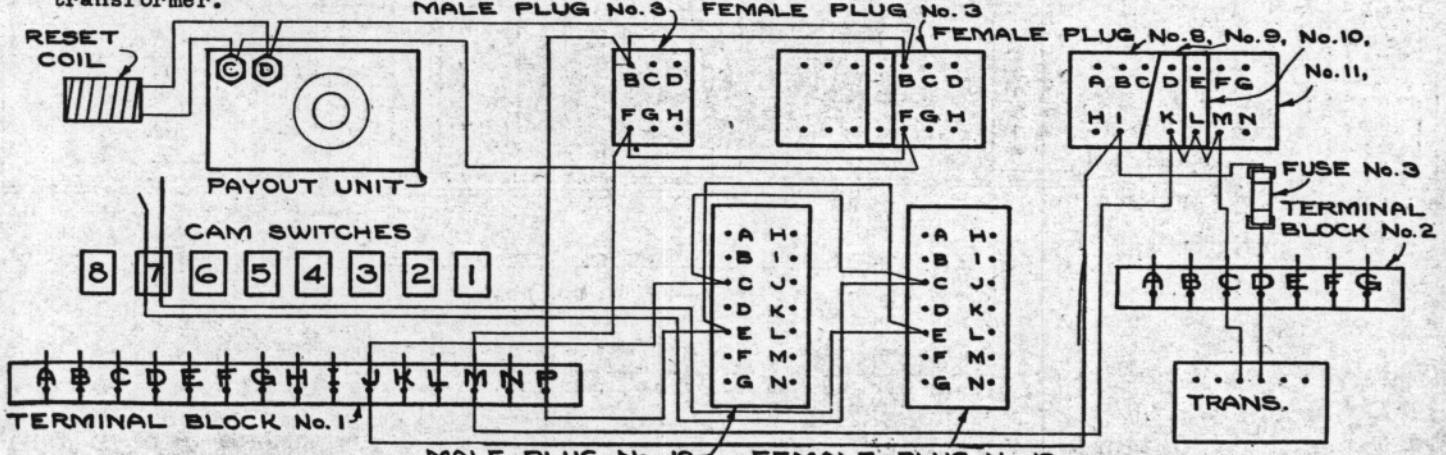

**CIRCUIT #14, PAYOUT RESET COIL-Through #7 cam switch**

Transformer to terminal block #3 D, yellow red wire to fuse #3, yellow red wire to female plug #8-I, yellow red wire to terminal block #1 J, yellow red wire to male plug #12 C, to female plug #12 C, yellow red wire to bottom of #7 cam switch, to top of #7 cam switch, orange black wire to female plug #12 E, to male plug #12 E, orange black wire to terminal block #1 P, orange black wire to male plug #3 B, to female plug #3 B, to binder post # D, to payout reset coil---to binder post #C, to female plug #3 F, to male plug #3 F, yellow wire to terminal block #1 M, yellow wire to female plug #9 K, jumper to female plug #11 M, yellow wire to terminal block #3 C, to transformer.

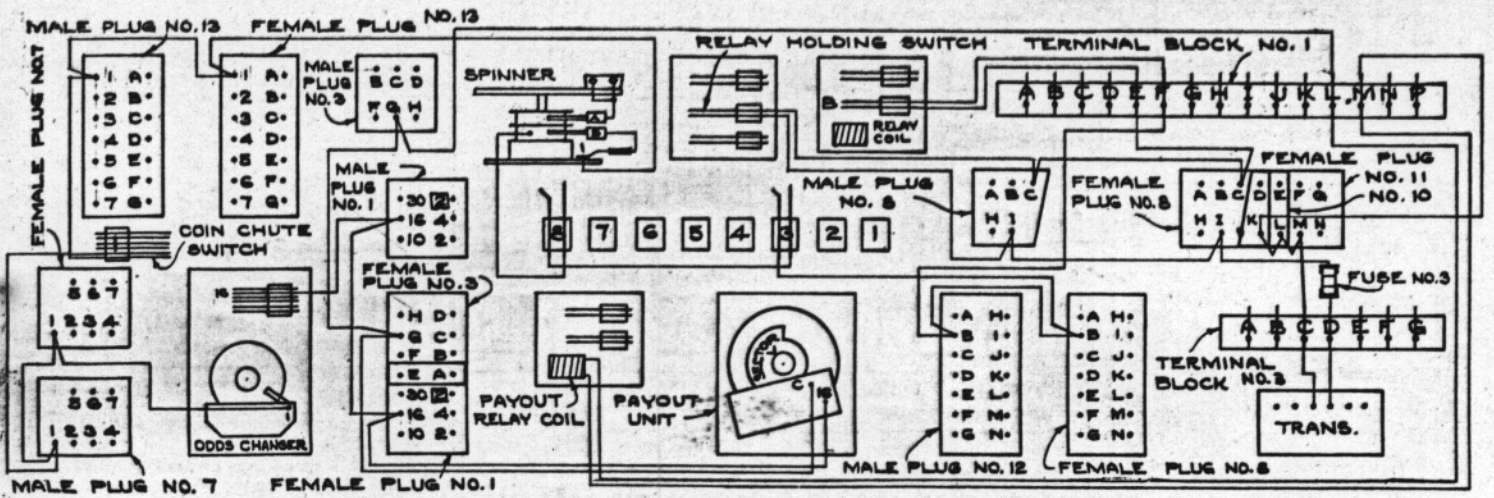

**CIRCUIT #15, PAYOUT RELAY COIL-Through #8 can switch**

(For #1 coin slot and 16 payout. Circuits through other coin slots and other payout numbers are similar)

The important contacts in Circuit #15 are: RELAY HOLDING SWITCH, MASTER RELAY SWITCH #8, #3 CAN SWITCH, #8 CAN SWITCH, SPINNER BRUSHES #8 & COMMUTATOR BRUSH, COIN CHUTE SWITCH #1, ODDS CHANGER COMMUTATOR BRUSH #1 & COLLECTOR RING BRUSH #16, PAYOUT UNIT COMMUTATOR CONTACT SECTOR V.

Transformer to terminal block #3 D, yellow red wire to fuse #3, yellow red wire to female plug #8-I, to male plug #8-I, yellow red wire to relay holding switch, yellow green wire to male plug #8 C, to female plug #8 C, yellow green wire to terminal block #1 E, yellow green wire to master relay switch #8, yellow green wire to terminal block #1 F, yellow green wire to male plug #12 B, to female plug #12 B, yellow green wire to bottom of #3 can switch, to top of #3 can switch, to bottom of #8 can switch, to top of #8 can switch, green white wire to spinner ring #8, to brushes #8, to spinner commutator brush, to commutator point #1, red wire to female plug #13-1, to male plug #13-1, red wire to coin chute switch #1, red white wire to male plug #7-1, to female plug #7-1, red white wire to odds changer commutator brush #1, to commutator point #16, to collector ring #16, to collector ring brush #16, orange wire to male plug #1-16, to female plug #1-16, to payout unit contact plunger No. 16, to commutator contact sector V, to contact plunger C, to female plug #3 G, to male plug #3 G, red white wire to terminal block #1 L, to payout relay coil---to terminal block #1 M, yellow wire to female plug #9 K, jumper to female plug #11 M, yellow wire to terminal block #3 C, to transformer.

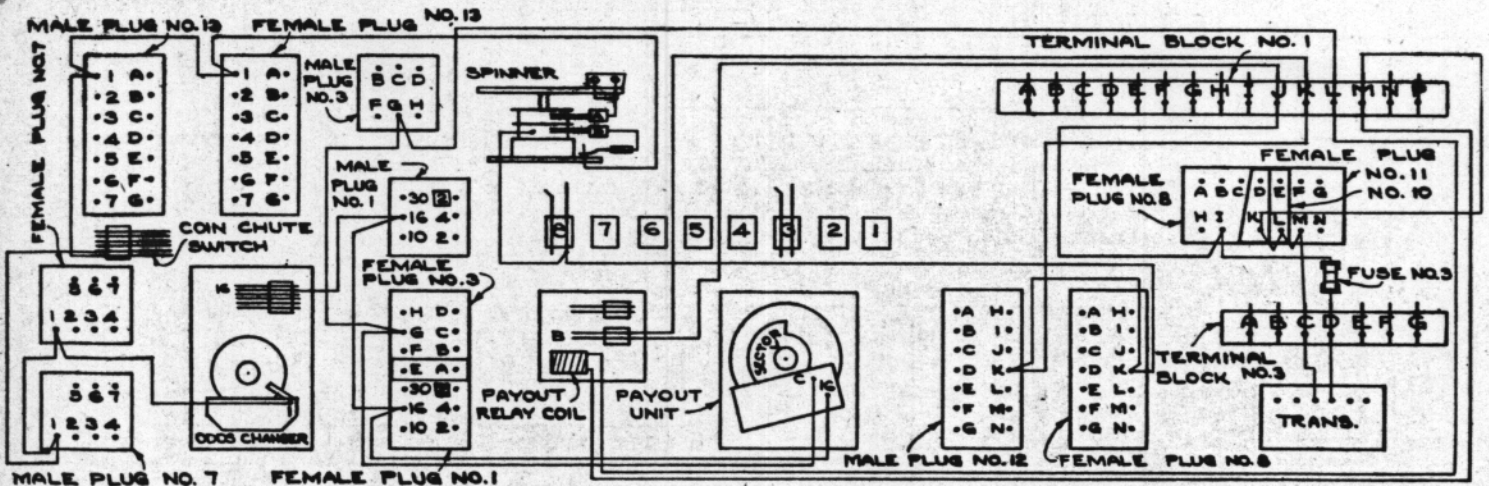

**CIRCUIT #16, PAYOUT RELAY COIL- Through payout relay switch #8.**

(For #1 coin slot and 16 payout. Circuits through other coin slots and other payout numbers are similar.)

The important contacts in Circuit #16 are: PAYOUT RELAY SWITCH #8, SPINNER BRUSHES #8 & COMMUTATOR BRUSH, COIN CHUTE #1, ODDS CHANGER COMMUTATOR BRUSH #1 & COLLECTOR RING BRUSH #16, PAYOUT UNIT COMMUTATOR CONTACT SECTOR V.

Transformer to terminal block #3 D, yellow red wire to fuse #3, yellow red wire to female plug #8-I, yellow red wire to terminal block #1 J, yellow red wire to payout relay switch #8, blue wire to terminal block #1 K, blue wire to male plug #12 K, to female plug #12 K, blue wire to top of #8 can switch, green white wire to spinner ring #8, to brushes #8, to spinner commutator brush, to commutator point #1, red wire to female plug #13-1, to male plug #13-1, red wire to coin chute switch #1, red white wire to male plug #7-1, to female plug #7-1, red white wire to odds changer commutator brush #1, to commutator point #16, to collector ring #16, to collector ring brush #16, orange wire to male plug #1-16, to female plug #1-16, to payout unit contact plunger No. 16, to commutator contact sector V, to contact plunger C, to female plug #3 G, to male plug #3 G, red white wire to terminal block #1 L, to payout relay coil---to terminal block #1 M, yellow wire to female plug #9 K, jumper to female plug #11 M, yellow wire to terminal block #3 C, to transformer.

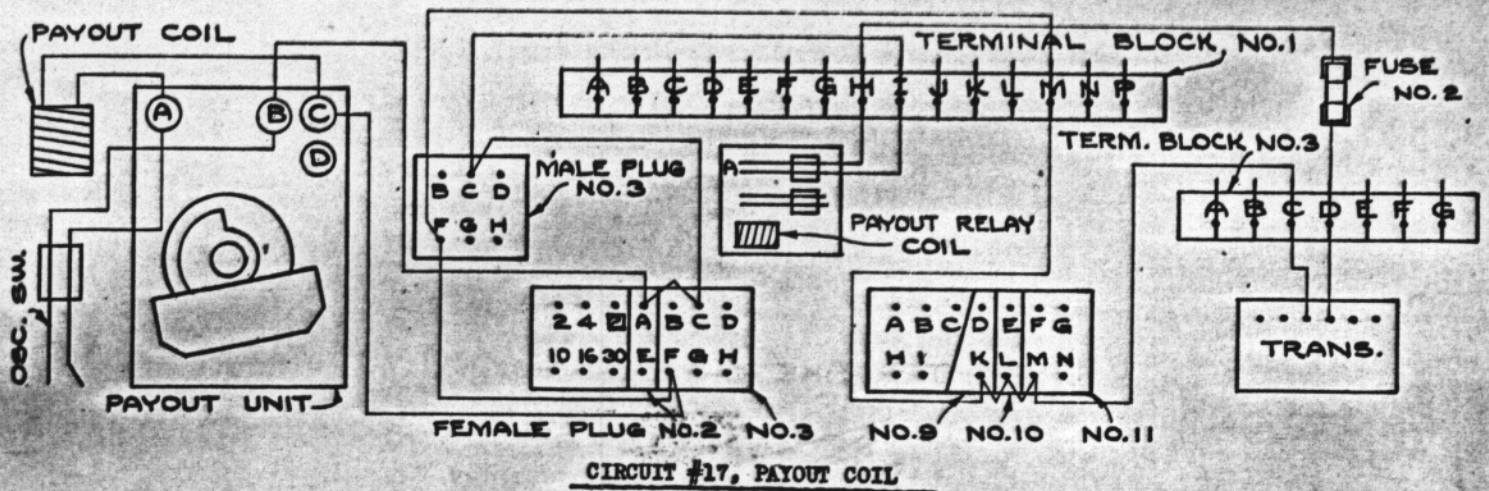

The important contacts in Circuit #17 are:  
 PAYOUT RELAY SWITCH #A & PAYOUT UNIT OSCILLATING SWITCH.

Transformer to terminal block #3 D, red wire to fuse #2, red wire to terminal block #1 H, red wire to payout relay switch #A, red wire to terminal block #1-I, red wire to male plug #3 C, to female plug #3 C, jumper to female plug #2 A, to binder post #B, to top of oscillating switch, to bottom of oscillating switch, to binder post #A, to payout coil---to binder post #C, to female plug #3 E, to male plug #3 F, yellow wire to terminal block #1 M, yellow wire to female plug #9 K, jumper to female plug #11 M, yellow wire to terminal block #3 C, to transformer.

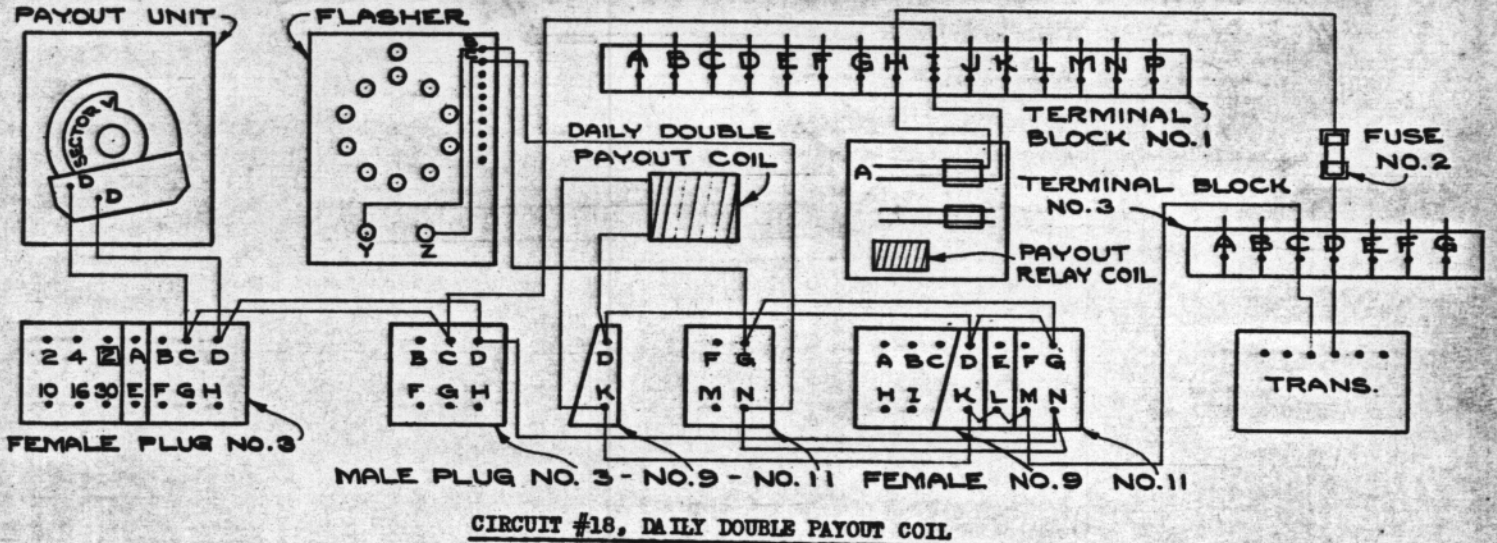

The important contacts in Circuit #18 are:  
 PAYOUT RELAY SWITCH #A PAYOUT UNIT COMMUTATOR CONTACT SECTOR V & FLASHER TWIN MOVING PLUNGERS.

Transformer to terminal block #3 D red wire to fuse #2, red wire to terminal block #1 H, red wire to payout relay switch #A, red wire to terminal block #1-I red wire to male plug #3 C, to female plug #3 C, to payout unit contact plunger D, to commutator contact sector V, to contact plunger D, to female plug #3 D, to male plug #3 D, blue yellow wire to female plug #11 N, to male plug #11 N, blue yellow wire to flasher terminal #C, blue yellow wire to rivet #2, to twin moving plungers, to rivet #Y, blue yellow wire to terminal #B, blue yellow wire to male plug #11 G, to female plug #11 G, jumper to female plug #9 D, to male plug #9 D, blue yellow wire to daily double payout coil---yellow wire to male plug #9 K, to female plug #9 K, jumper to female plug #11 M, yellow wire to terminal block #3 C, to transformer.

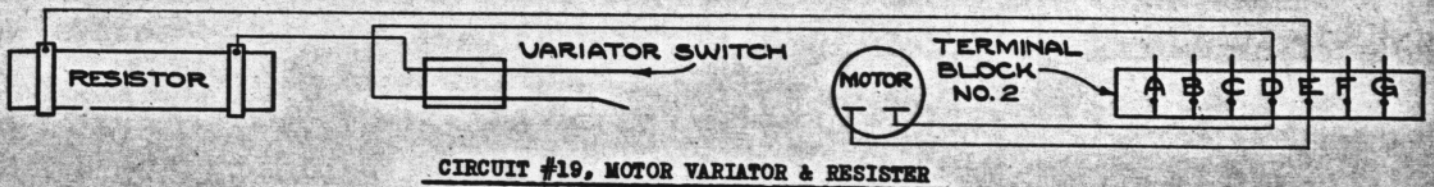

The important contact in Circuit #19 is:  
 Variator Switch.

Variator lead on motor, yellow wire to terminal Block #2 E, white red wire to bottom of resistor, to top of resistor, to top of variator switch, to bottom of variator switch to terminal block #2 D, yellow wire to motor.

(VARIATOR SKETCH)

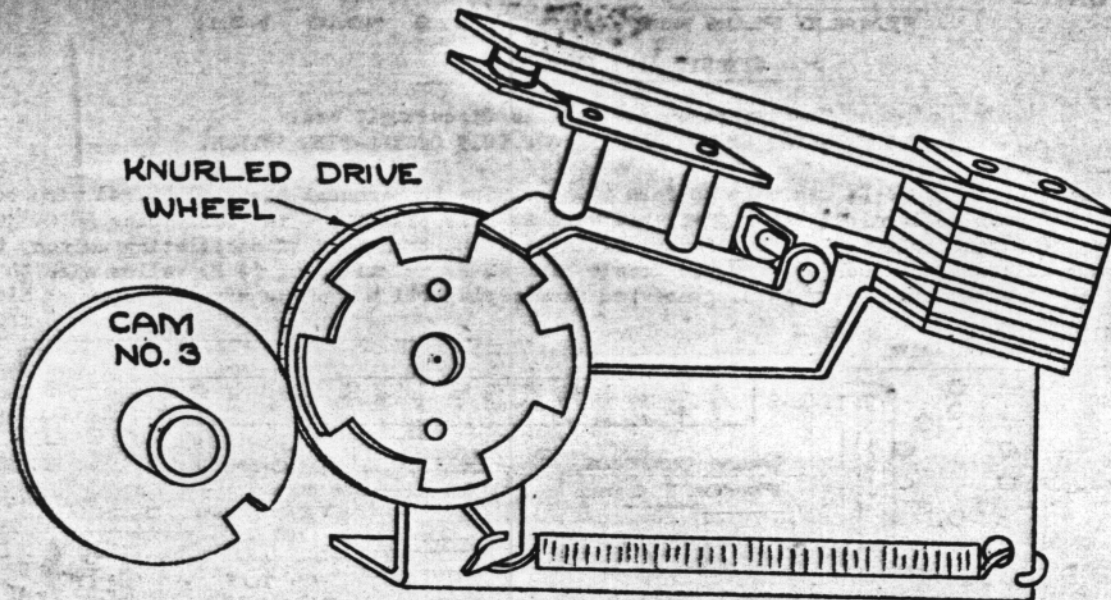

VARIATOR

The Variator used in Buckley Console machines consists of a mechanically operated cam switch mechanism. This cam operates two sets of switches. #1 Set of switches governs the speed variations of the odds changer. #2 Set of switches govern the speed variations of the Spinner. To realize the full benefits of this Variator, the knurled drive wheel must be in constant contact with #3 cam. (See sketch Variator).

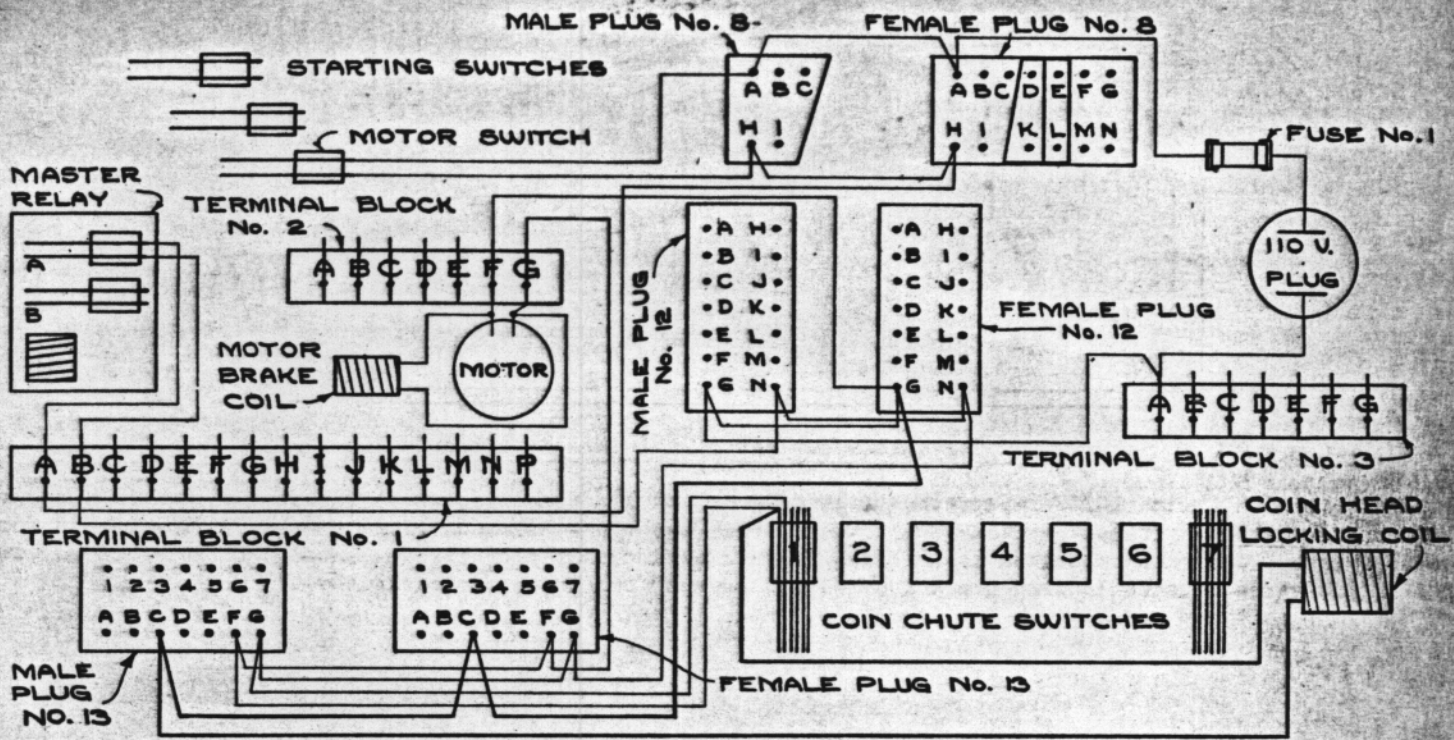

Circuit #20 Coin Head Locking Coil

110 volt plug, black wire to fuse #1, black wire to female plug #8 A, to male plug #8 A, black wire to motor starting switch, black wire to male plug #8 H, to female plug #8 H, black wire to terminal block #1 A, Black wire to master relay switch A, black wire to terminal block #1-B, black wire to male plug #12 H, to female plug #12 H, black wire to female plug #13 G, to male plug #13 G, black wire to coin chute outside switches, black wire to male plug #15F, to female plug #15 F, black wire to terminal block #2 G, to motor & motor brake coil---to terminal block #2 F, black white wire to female plug #12 G, to male plug #12 G, black white wire to terminal block #3 A, black white wire to 110 volt plug. Black wire from coin head locking coil, to outside of coin chute switches. Black white wire from coin head locking coil to male plug #13-C, to female plug #13-C to female plug #12-G.

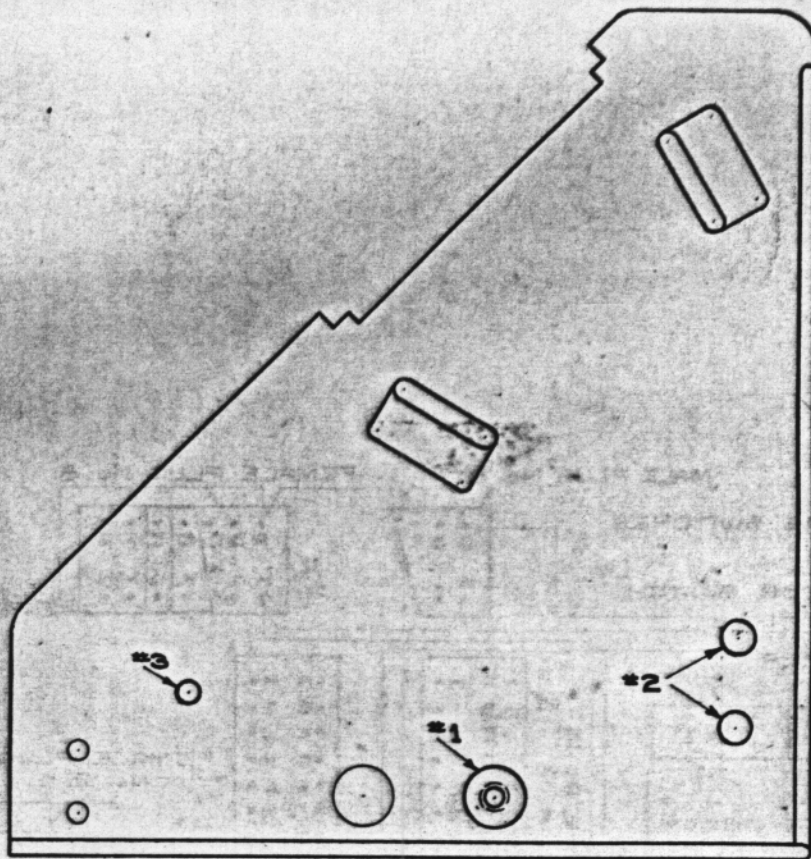

**Instructions to Install Coin Head Locking Coil**

Tap hole (marked #1) with 10/32 Tap; fasten locking arm with 10/32 shoulder screw, fasten spring to pump lug between steel washer and spacer (marked #3, fasten coil, through 2 holes on frame (marked #2). Brass screw on coil armature should be adjusted as follows: Push armature inside of coil, then adjust the Brass screw for 1/32 clearance between locking arm and notched corner on handle lever (marked #4).

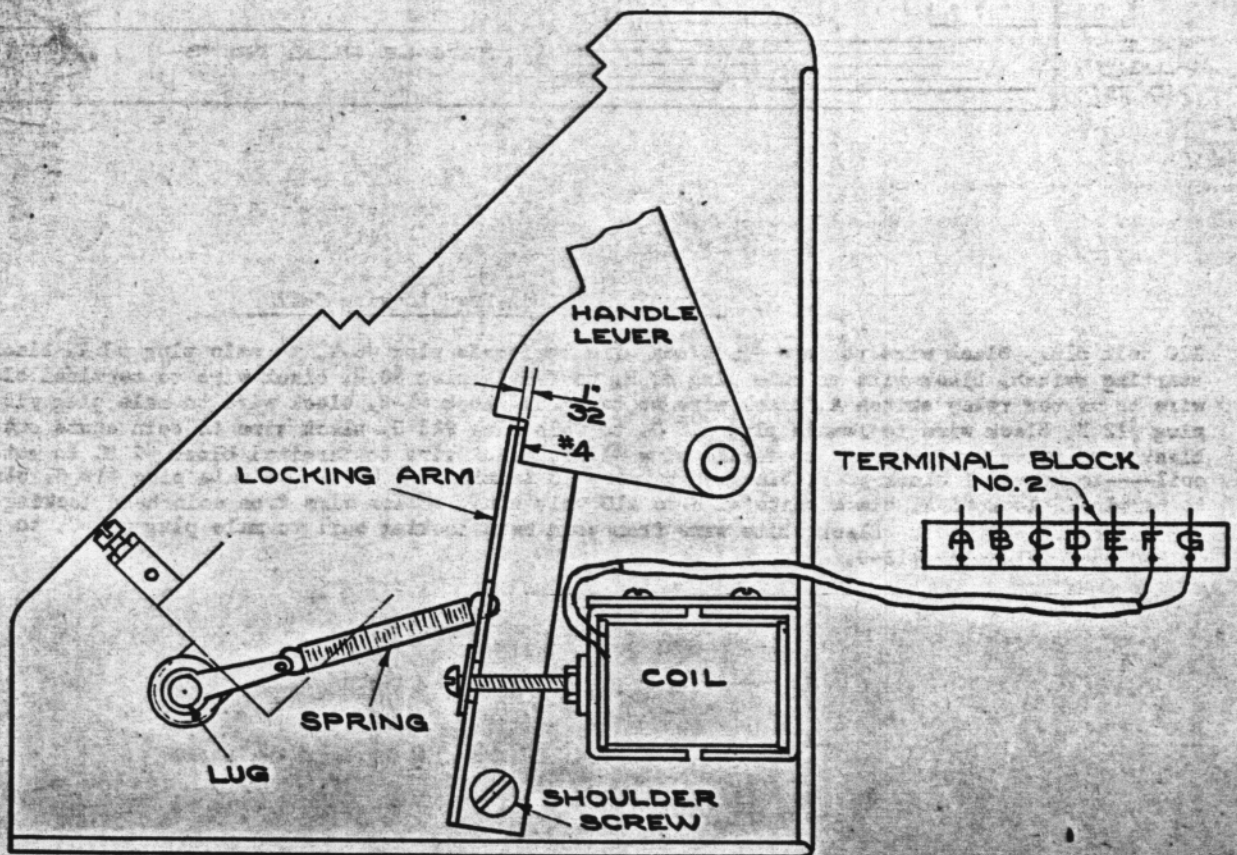

Attach 2 wires from coin head locking coil, to black wires on terminal block #2 F and G.









**20** 2 10 2 2 4 16  
 4 4 2 4 4 2 16  
 2 2 4 2 10 2 10  
 4 4 2 4 2 4 10  
 10 2 4 2 4 2 20  
 2 4 2 16 2 4 16  
 4 2 4 4 4 2 16  
 2 2 2 2 2 4 10  
 4 4 16 4 4 2 10  
 2 2 4 2 2 2 16  
 4 4 2 4 16 4 16  
 2 2 4 2 4 2 16  
 16 4 2 4 2 4 10  
 4 2 4 10 4 2 10  
 2 4 2 2 2 4 16  
 4 2 4 4 4 2 16  
 2 2 10 2 2 4 16  
 4 4 2 4 2 10  
 2 2 4 4 10 2 10  
 10 4 2 2 4 2 16  
 2 2 4 10 2 20 10  
 4 4 2 2 4 10  
 2 2 4 4 4 2 20

DAILY DOUBLE JACKPOT PARTS  
ODDS CHANGER UNIT PARTS

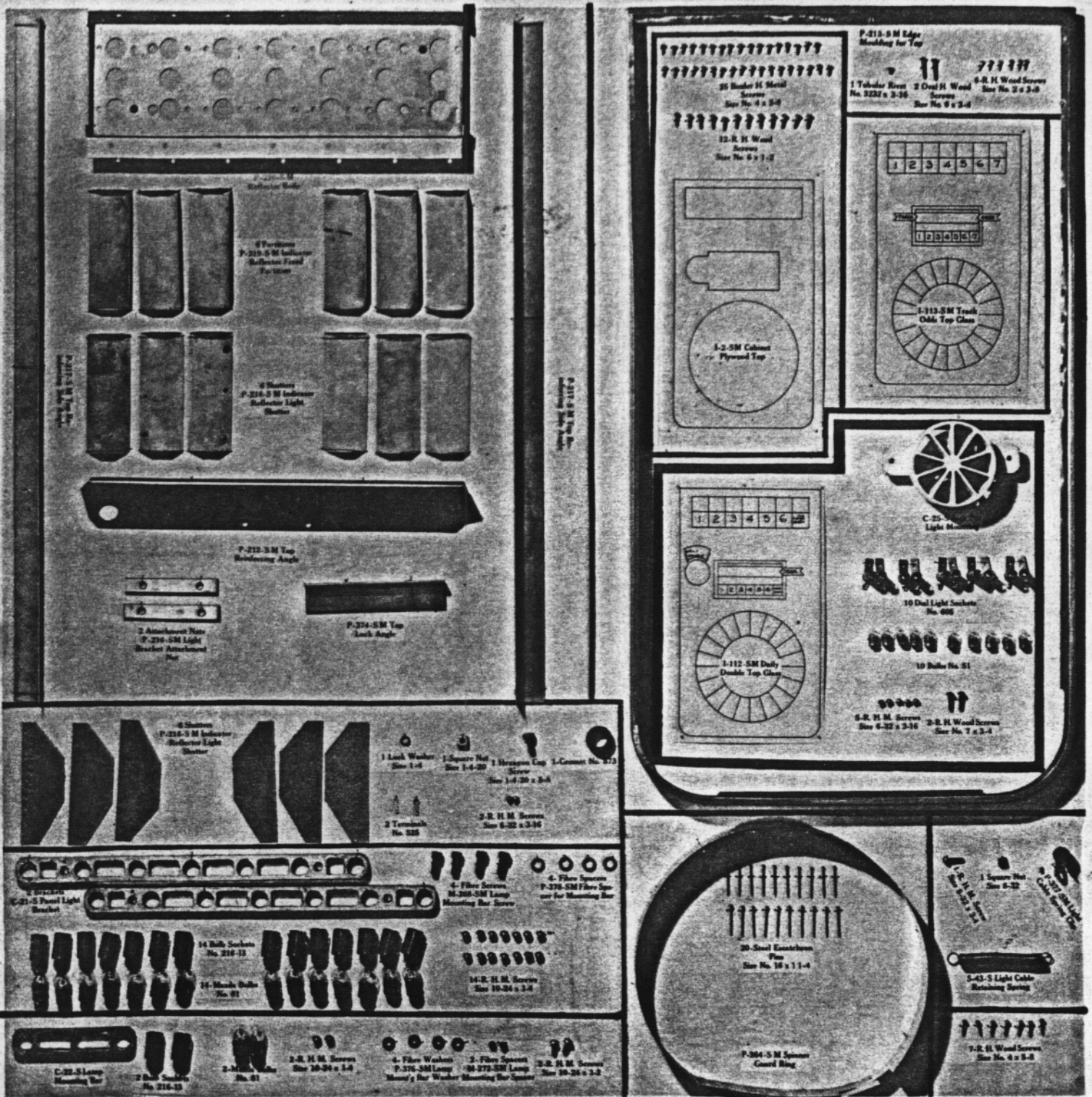

CABINET TOP PARTS