

FACTS!

Concerning

A Deluxe Machine

Designed and Built

for the

ESTABLISHED OPERATOR

BUCKLEY MANUFACTURING CO.

2160 W. WASHINGTON BLVD. CHICAGO, ILLINOIS



A STRIKING DEMONSTRATION OF TUF-FLEX STRENGTH AND FLEXIBILITY

Tuf-Flex

Used Exclusively in Buckley Console Models

To The Operator

You should install Track Odds in your best locations.

Because it will make the most money over the greatest period of time. Its bright, colorful playing field, its simplicity, its mutuel feature, provide the thrill and fascination of an actual horse race.

Track Odds has the same appeal that has made horse racing the oldest and most popular sport in the world.

The operator who buys Track Odds makes a permanent investment. No longer will it be necessary to change machines every month or two.

Top Glasses

The top glass used in Buckley's console machines is something new and different and is presented for the first time in the coin machine business. It is called "TUF-FLEX", a newly patented, tempered plate glass that offers super-strength and perfect clearness. While it is not claimed to be unbreakable, it is a proven fact that TUF-FLEX will stand at least 50% more abuse than the finest grade plate glass of the same thickness. For this reason, it adapts itself ideally for use in a machine of the console type. TUF-FLEX cannot be cut or drilled with any known instrument or tool and therefore offers maximum protection.

Each top is attractively and brilliantly laid out with color schemes perfectly suited for the various types of games offered.

Cabinets

Newly designed, modernistic, all steel, electrically welded cabinets—finished in a manner comparable to the most modern and finest automobile bodies. The use of steel cabinets in coin-operated machines is a forward step in the industry's progress.

All cabinets are equipped with heavy, modernistic, chrome plated feet, self leveling and adjusting. Ample space is provided for the use of weights and each cabinet has been scientifically constructed to provide proper ventilation so as to eliminate any possibility of the mechanism over-heating.

Multiple Coin Chute

The coin head used is of the multiple seven slot type—carefully tested in our factory under actual operating conditions for at least 1000 plays. We recommend it as being the only multiple coin head available that will operate with maximum efficiency. Chart proof—gyp proof—manipulation proof. Easy to service if necessary. Any separate slot can be played or all seven slots can be played or any combination of the seven slots can be played at one time.

The last four coins played in each slot are clearly visible, thus practically eliminating the slug nuisance. The handle is provided with a clutch to prevent breakage from violent usage.

Payout Unit

Buckley console machines are equipped with the famous Buckley PAYMASTER unit, the one which has been so sensationally popular on more than 10,000 automatic payout machines and which has been generally approved by qualified engineers and operators as representing the finest and most compact piece of automatic payout equipment ever developed. Extremely rapid in its action, positive in its payouts—the PAYMASTER is your assurance of complete payout satisfaction.

Odds Changer

To add greater player appeal and to further eliminate the charting practice so commonly followed on all other machines of the spinner type, we have developed and use our own exclusive changing odds reel.

The drum is equipped with 24 stops and makes from two to four complete revolutions every time the machine is played. Non-wearing contacts are positive in action, thus assuring a correct payout.

Spinner

The spinner used is one of our own exclusive design. It is what we call a "free-wheeling" style. By this we mean that it operates in a manner exactly the opposite of the usual spinner device in that the power from the motor is automatically thrown off as soon as it has reached a certain speed, from this point and until it comes to a final stop, the spinner moves under its own momentum on roller bearings which require no lubrication. Through the use of this "free-wheeling" feature we have eliminated any possibility of the players cheating the spinner, because under our system there is a variable speed on each and every play. This is an exclusive feature found only in Buckley consoles.

Power Pack

The power-pack used in Buckley console machines is the largest ever used in a coin-operated product. It was designed especially for our use and tests of as many as 1000 continuous hours play have shown them to be the most satisfactory device of this kind yet developed. Being extra large, with extra capacity and designed for heavy continuous duty without over-heating, these power packs will give you maximum service for the life of the machine itself.

Provisions are made for variation in local current supply. Current is shut off automatically within two minutes after machine has been played.

Lights

The Track Odds top is brilliantly laid out with an eye arresting color scheme. The public is instantly attracted by the extraordinary flash of its constant illumination. This is accomplished by a separate light transformer, entirely independent of the power pack, using very little current. All bulbs are in duplicate, so that the accidental burning out of one bulb will not result in an unnecessary service call.

Electrical Circuits

Simplified to the last degree.

Instructions and wiring diagrams made clear to the average operator, regardless of previous experience with electrical machines.

Weights and Dimensions

Net weight—203 pounds.

Gross weight packed for shipment—309 pounds.

Dimensions of shipping case:

22³/₄ inches x 45³/₄ inches x 47¹/₂ inches.

I N S T R U C T I O N S

(THESE INSTRUCTIONS ARE ONLY FOR MACHINES
WITH SERIAL NUMBERS OF 11,000 OR OVER)

T O P G L A S S

To lift top glass, remove cash box, unscrew wing nuts fastened to upper part of opening.

C O I N C H U T E

The coin chute housing is one solid assembly. In order to remove the housing, lift up playing field glass, push out pins (marked red) the ends of which appear in the two lower corners, underneath the housing casting. Any small tool is suitable for this purpose. After pins have been removed, housing can be lifted from mechanism. Unscrew yellow screws and remove plate to gain access to coin chute switch contacts. When replacing coin chute housing, hold handle at its farthest back position to insure positive engagement of actuating part.

C L O C K

Inside of the clock, which is located on the starting switch bracket underneath the coin chute, is an electrical contact switch. The clock switch remains closed for two minutes after each play. Then the switch opens automatically and shuts off the large power pack. IMPORTANT: Whenever the coin chute clock is ticking the power pack should be operating, which is indicated by a buzzing sound. Should this buzzing sound not be heard, look at the clock contact switch, as, undoubtedly you will find it open when it should be closed. If this is not the trouble, trace circuit #5.

C O I N C H U T E C O N T A C T S W I T C H E S

There are seven sets of double contact switches located in the back of the coin chute mechanism. These switches control the lights in the seven (7) panels located in the upper end of the glass top, and also the payoff mechanism. For example:- when a coin is placed in any slot, the double switch in the back of that particular slot is closed. One of these switches illuminates the light-up panel corresponding to the slot in which the coin has been placed. The other switch closes the circuit which leads to the corresponding contact on the spinner commutator. If the spinner stops on this number, the circuit is completed and the machine pays off.

M O T O R S T A R T I N G S W I T C H E S

There are three contact switches located in the cabinet under the coin chute. The bottom switch "A" is the master relay closing switch. The center switch "B" is the master relay holding switch. The top switch "C" is the motor starting switch.

The bottom switch "A" is closed only for an instant when a coin is played. At all other times this switch is open. IMPORTANT:- If the bottom switch "A" is closed when it should be open, the machine will run continuously without the insertion of a coin.

The center switch "B" is closed when the bottom switch "A" is closed. It then opens for an instant and again closes when the top switch "C" is closed.

The top switch "C" is open for an instant when a coin is played, but at all other times it is closed. IMPORTANT:- if the top switch "C" is open when it should be closed the motor will not start.

F U S E S

There are three (3) fuses on the machine.

The light fuse, #1 (3 amp), is located on the small transformer. This fuse covers only the small light transformer and the light circuit.

The main fuse, #2 (5 amp), is located next to the 110 volt plug. This fuse covers the 110 volt line and if it blows out the entire mechanism becomes inoperative.

The power pack fuse, #3 (5 amp), is located next to the large power pack. This fuse covers circuits #8, 9, 14, 15, 16 and 17.

P O W E R P A C K

The power pack reduces and converts the 110 volt alternating current to approximately 14 volts direct current. The power pack supplies current to every part of the machine except the light transformer, the motor and the motor brake. The foregoing parts are supplied with 110 volt alternating current. The operation of the power pack should not be confused with the small light transformer, as they are independent of each other. The power pack will operate the mechanism efficiently when it is delivering a minimum of 12 volts.

L I G H T T R A N S F O R M E R

The light transformer reduces the 110 volt alternating current to approximately 8 volts, which is the necessary voltage required to illuminate the bulbs. The light transformer does not supply any power to any part of the mechanism and is used only to supply the current to the light circuits.

C O M M U T A T O R S

There are three (3) commutators. They are located on the spinner, odds changer and payoff mechanism. **IMPORTANT:-** keep these points lubricated, using petroleum jelly (vaseline). The lubrication of these points will keep the contacts clean and prevent corrosion.

C O N D E N S E R

The condenser is the tubular piece of metal fastened on top of the pay-out unit commutator. The purpose of the condenser is to absorb the arc (flame) produced by the oscillating switch, thereby preventing corrosion and burning of the oscillating switch contact points.



I N S T R U C T I O N S

FOR REMOVING PAYOUT MECHANISM, ODDS CHANGER, AND SPINNER

P A Y O U T M E C H A N I S M

Pull out male plug fastened on top of payout mechanism. Then remove red screws on payout base. Loosen green screws on steel parts fastened to payout tube, slide each of these steel parts down about one inch (1") then turn mechanism slightly and lift out of cabinet.

When mechanism is replaced, be sure to line it up on the base so that the coins will properly feed into the tube. Also be sure to set steel parts on tube back in their original location.

O D D S C H A N G E R

Pull male plugs #1, #2, #3 and #5. Remove four screws holding bakelite contact strip. Remove four nuts fastening legs of odds changer. Then lift odds changer from the cabinet.

When replacing the odds changer be sure to locate it in its original position.

S P I N N E R

Pull male plugs #5, #6 and #7. Then remove the three nuts fastening the spinner to the board and lift spinner from cabinet.

SEQUENCE OF CAM CONTACT SWITCHES

- #1 cam switch runs the motor. This switch is open at the beginning of the cycle.
- #2 cam switch closes the master relay. This switch is closed at the beginning of the cycle.
- #3 cam switch shuts off the motor when its cycle is completed. This switch is closed at the beginning of the cycle.
- #4 cam switch energizes the coil which engages clutch on the spinner, causing arm to revolve. This switch is open at the beginning of the cycle.
- #5 cam switch energizes the coil which releases the brake on the spinner gear and again applies this brake when the switch contact opens near the end of its cycle. This switch is closed at the beginning of the cycle.
- #6 cam switch energizes the coil which spins the odds changer. This switch is open at the beginning of the cycle.
- #7 cam switch energizes the small coil located in the payout mechanism. When this coil is energized the brush on the payout mechanism commutator is released bringing it back to its starting position. This switch is open at the beginning of the cycle.
- #8 cam switch energizes the payout relay coil which completes the #14 payout circuit, allowing the payoff mechanism to complete the pay-off designated on the odds changer. This switch is open at the beginning of the cycle.
- #9 cam switch energizes the booster coil which insures the closing of the payout relay in the event that the #8 cam switch fails to close it.

INSTRUCTIONS ON THE VARIOUS SERVICE CALLS

IF MACHINE FAILS TO START WHEN COIN IS PLAYED

1. See that the power cord is plugged in.
2. Inspect fuse #2.
3. Trace circuit #5, especially clock switch.
4. See that starting switch rod is working freely and returning to its original starting position.
5. When handle is held down after putting coin in slot master relay should be closed. If it is not closed check circuit #8, especially relay closing switch.
6. If master relay is closed when handle is down, but opens when handle is returned, check circuit #9, especially relay holding switch and master relay switch #A which should both be closed when handle has been returned.
7. If circuits #8 and #9 are O.K., check circuit #6, especially motor starting switch and master relay switch #B which should both be closed when handle has been returned.

L I G H T S

A. IF ALL LIGHTS FAIL TO LIGHT

1. Inspect fuses #1 and #2.
2. Trace circuit #1.

B. IF PANEL LIGHTS FOR A PARTICULAR NUMBER FAIL

1. See that coin chute switch is closed.
2. Check blade of upper contact strip.
3. Inspect bulbs and sockets.
4. Check circuit #4.

C. IF ALL PANEL LIGHTS FAIL

1. Check action of switch carrier plate on coin chute.
2. Check action of pump controlling switch carrier plate.
3. Check alignment of upper and lower contact strips, if adjustment is necessary, loosen odds changer and shift to proper position.
4. Check circuit #4.

D. IF A PARTICULAR LIGHT ILLUMINATES WHEN A COIN IS NOT PLAYED

1. See that the light contact switch in the coin chute is not closed when there is no coin in the corresponding slot.

E. IF SPINNER LIGHTS FAIL

1. Check bulbs and sockets.
2. Check spinner ring brushes #1.
3. Check circuit #3.

F. IF ODDS CHANGER LIGHTS FAIL

1. Check bulbs and sockets.
2. Check alignment of points #8 and #9 on contact strip.
3. Check circuit #2.

PAYOUT UNIT

- A. IF MACHINE DOES NOT PAY OUT ON ANY PLAYED SLOT (coil fails to act)
1. Check plugs #1, #2, #3, #5, and #6. They should be pushed down firmly in the female plugs.
 2. Check alignment of odds changer brushes with odds changer commutator points.
 3. Check coin chute switches. They should be closed when coins are located in front of the switch plungers.
 4. Check payout unit oscillating switch for loose connections or failure to make proper contact.
 5. Check payout unit connecting rod which is fastened to shaft in large payout coil. If this rod is broken, coil will energize but will not pull coin ejector slide forward to eject the coins.
 6. Check spinner commutator brush, be sure that it is pressing against all the buttons to make positive contact.
 7. Check circuit #14.
- B. IF MACHINE DOES NOT PAY OFF BUT THE PAYOUT MECHANISM MAKES A CLICKING NOISE
1. This trouble is caused by coins being turned in the payout tube. There is a hole drilled in the cabinet underneath the payout tube; insert screw driver into this hole and loosen coin jam. If it is impossible to settle these coins into their proper position, remove the payout mechanism and straighten coins in tube.
- C. IF UNIT PAYS OUT ONLY 1 TO 4 WHEN IT SHOULD PAY MORE
1. Check payout relay coil. This coil should remain closed until payout is completed.
 2. If coil fails to remain closed for duration of payoff, check circuit #13.
 3. Check relay coil switch.
 4. If switch is O.K. check circuit #13 from power transformer to spinner.
 5. If payout coil fails to return to starting position, disconnect condenser (small metal tube located on top of payout mechanism). If this corrects the trouble install a new condenser. (Payout unit will work without condenser, but will work more efficiently with condenser.)
- D. IF UNIT FAILS TO PAY ON A CERTAIN SLOT WHICH HAS BEEN PLAYED
1. Check coin chute switch.
 2. Check spinner commutator contact.
 3. Check odds changer commutator contact (#7 slot has 2 contacts).
 4. Trace circuit #14 through spinner, coin chute and odds changer.
- E. IF UNIT FAILS TO PAY OUT ON A CERTAIN DENOMINATION
(2, 4, 6, 10, 16 or 30)
1. Check odds changer collector ring contact.
 2. Check payout unit brush contacts.
 3. Check circuit #14 through odds changer and payout unit.
- F. IF UNIT PAYS OUT MORE THAN THE AMOUNT SHOWN ON ODDS CHANGER
1. Check springs on actuating and retaining pawl of payout gear.
- G. IF MACHINE PAYS OUT WHEN NO COIN IS PLAYED
1. Check coin chute switch.

PAYOUT UNIT (con't.)

H. IF UNIT PAYS OUT 1 OR FAILS COMPLETELY

1. Check return action of payout unit commutator brush. Be sure that brush does not bind when it returns to starting position.
2. Check contact of brush fingers. Be sure that they are pressing firmly against the commutator points.
3. Check circuit #13.

ODDS CHANGER

A. IF DRUM STOPS BETWEEN ROWS OF NUMBERS

1. Check action of spring which returns coil shaft; if it is weak, replace it.
2. See that drum is not dragging on drum cover, coil or bakelite brush mounting.

B. IF ODDS CHANGER ADJUSTMENT HAS BECOME LOOSE OR BEEN INCORRECTLY ADJUSTED

1. To set, locate the hole drilled in the commutator opposite the #1 switch, then set the paper so the first row (2 - 6 - 4 - 4 - 4 - 2 - 30) appears through the opening of the glass.

S P I N N E R

A. SPINS ONLY A FEW TURNS

1. Turn red screw located on spinner coil to the LEFT. Correct adjustment allows spinner to revolve from 9 to 12 revolutions. This is the adjustment for the best variation.

B. IF THE SPINNER REPEATS

1. Level the machine.
2. Make adjustment of spinner coil for 9 to 12 revolutions.



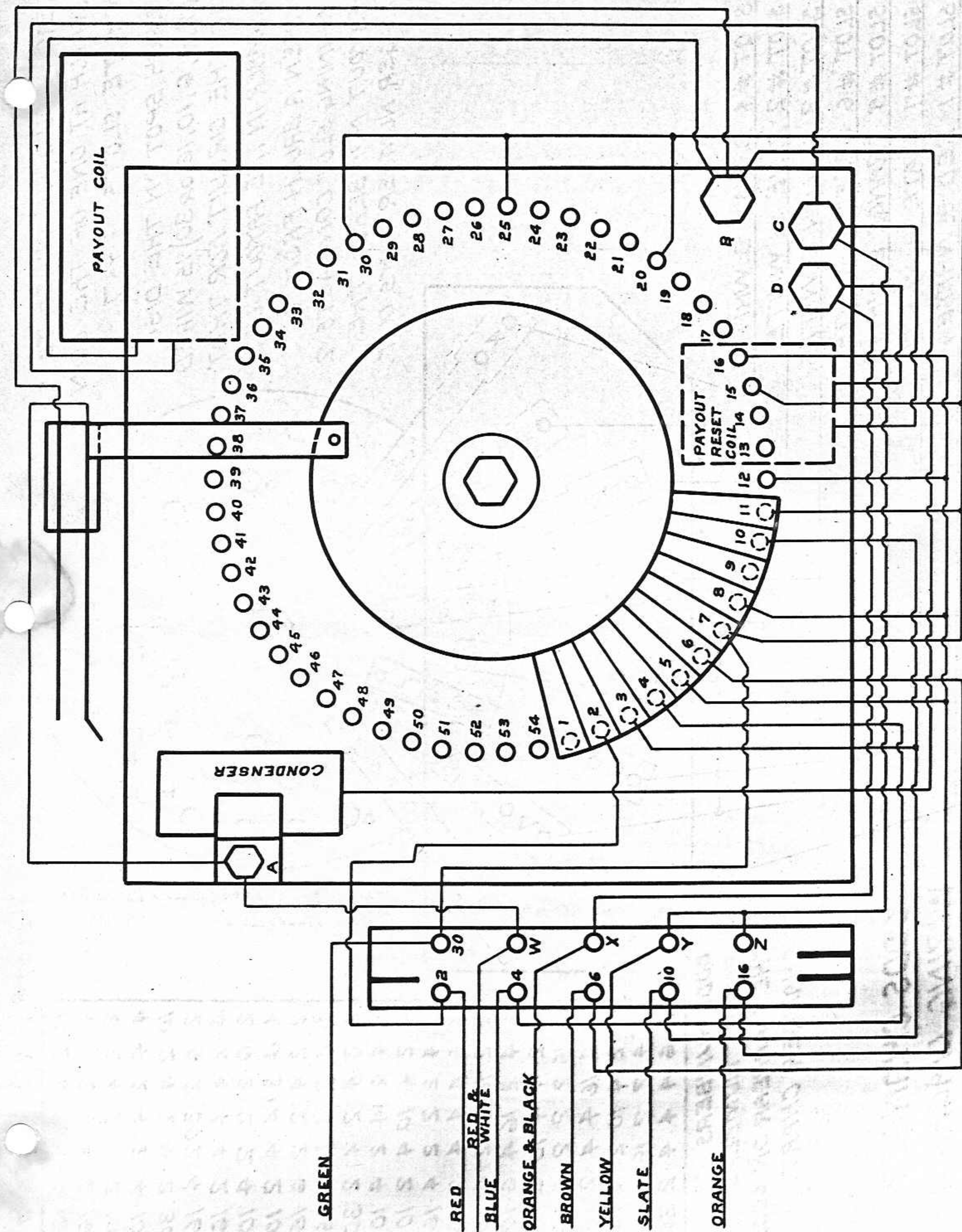

PAYMASTER WIRING DIAGRAM.

8-30-1938

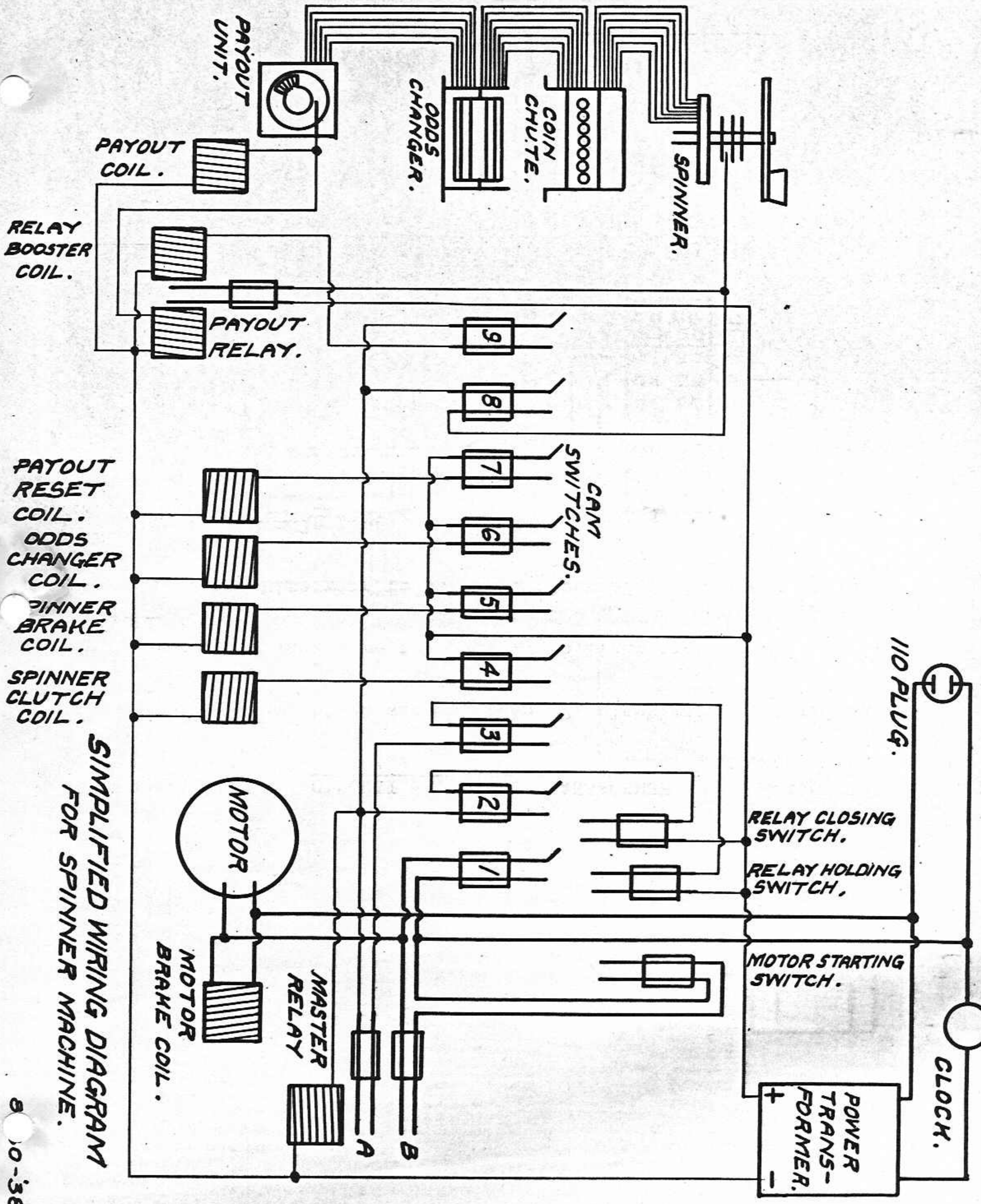

SIMPLIFIED WIRING DIAGRAM
FOR SPINNER MACHINE.



CIRCUIT #1, LIGHT TRANSFORMER

110 Male plug, black wire to fuse #2, black wire to terminal
block #3A, black wire to fuse #1, to light transformer —
black and white wire to terminal block #3B, black and white
wire to 110 male plug.

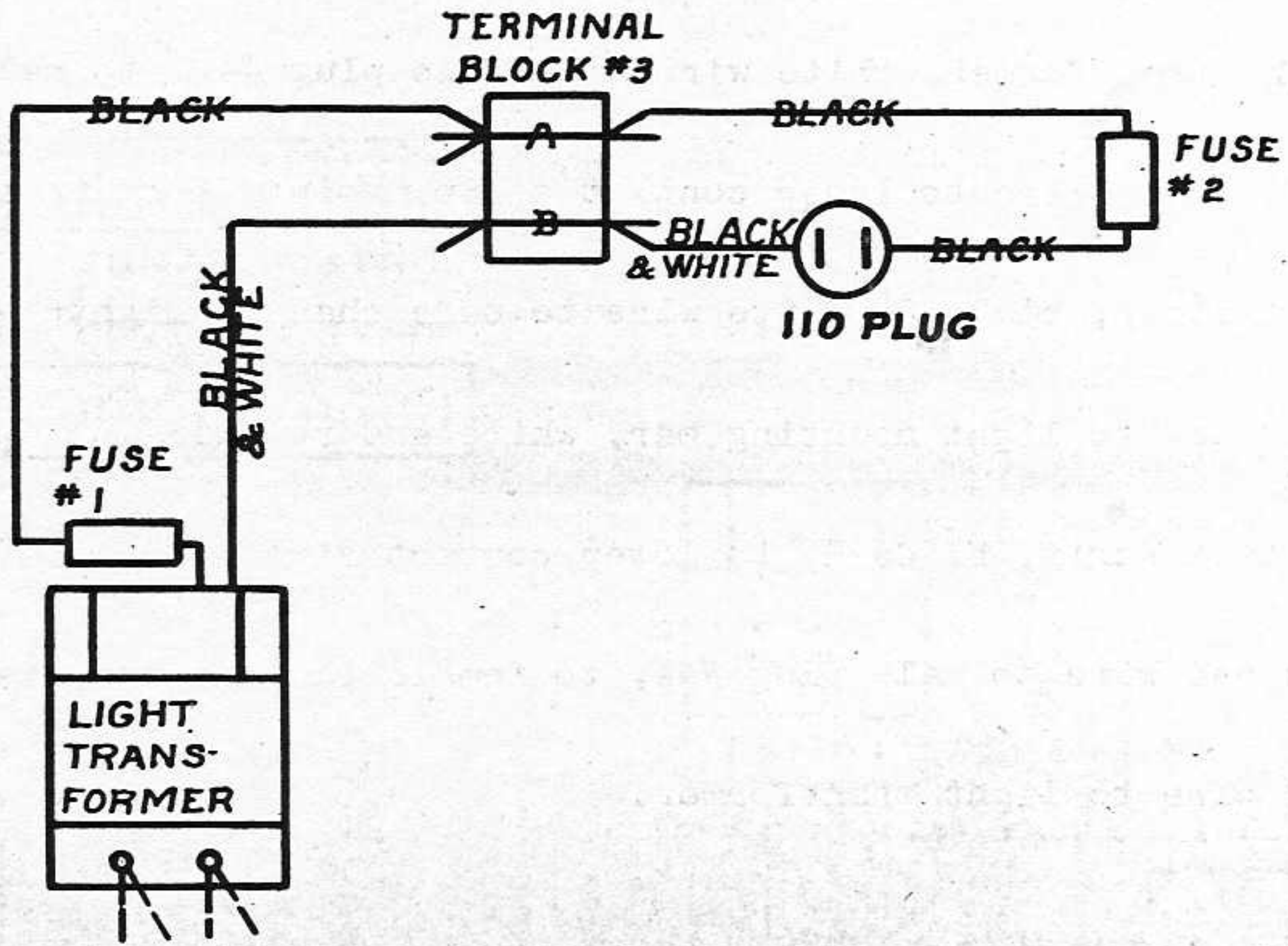

CIRCUIT # 1
LIGHT TRANSFORMER.
8-23-1938

CIRCUIT #2, ODDS CHANGER LIGHTS (Illuminated continuously)

Light transformer, white wire to female plug #4C, to male plug #4C, white wire to lower contact strip, point 8, to upper contact strip, blade 8, white wire to odds changer lights — grounded to light mounting bar, white and red wire to upper contact strip, blade 9, to lower contact strip, point 9, white and red wire to male plug #4A, to female plug #4A, white and red wire to light transformer.

CIRCUIT # 2
LIGHT TRANSFORMER
8-53-1978

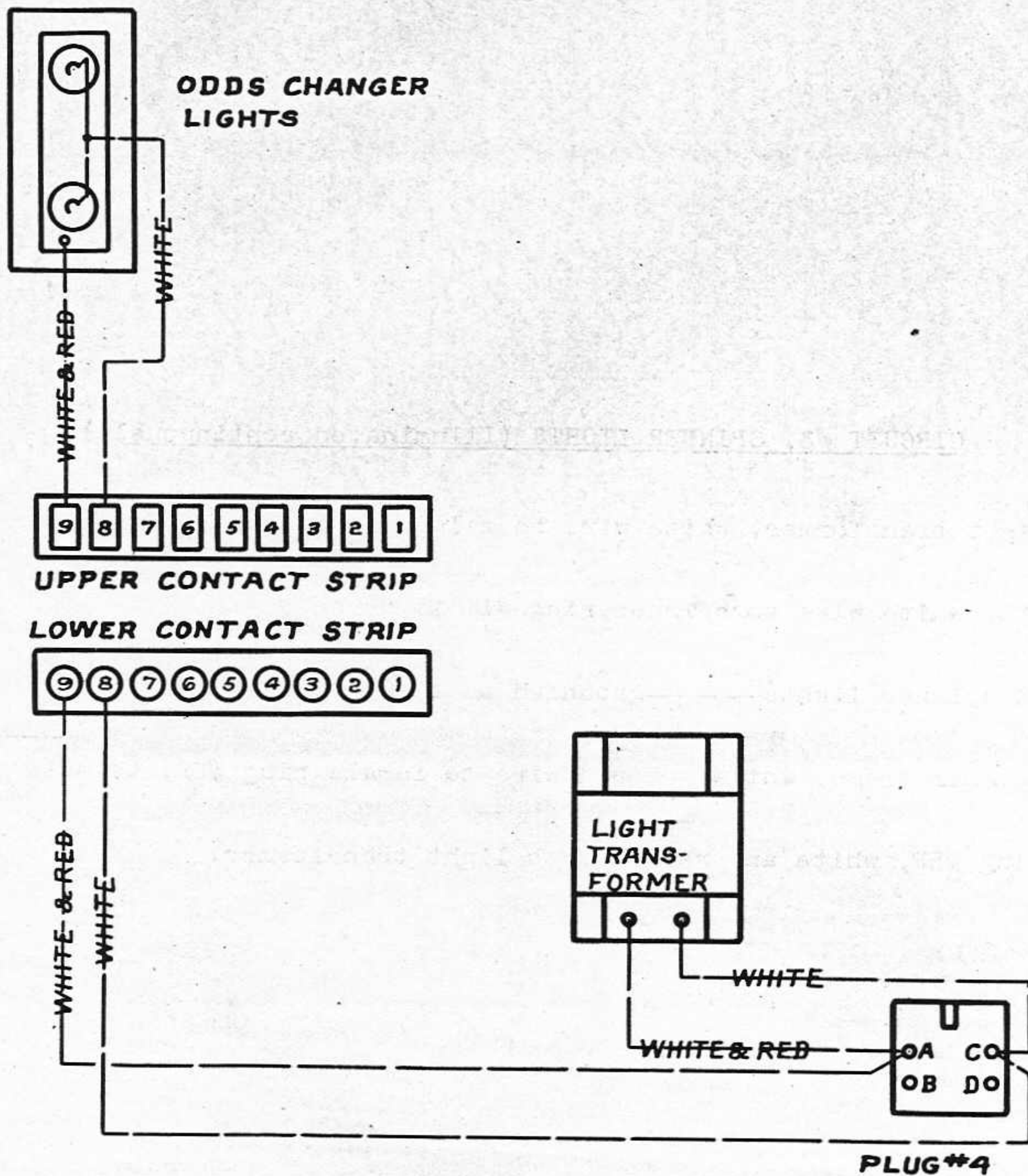

CIRCUIT #2
ODDS CHANGER LIGHTS.

CIRCUIT #3, SPINNER LIGHTS (Illuminated continuously)

Light transformer, white wire to male plug #5L, to female plug #5L, white wire to spinner ring #1, to brushes #1, white wire to spinner lights——grounded to light mounting bar, to spinner frame, white and red wire to female plug #5F, to male plug #5F, white and red wire to light transformer.

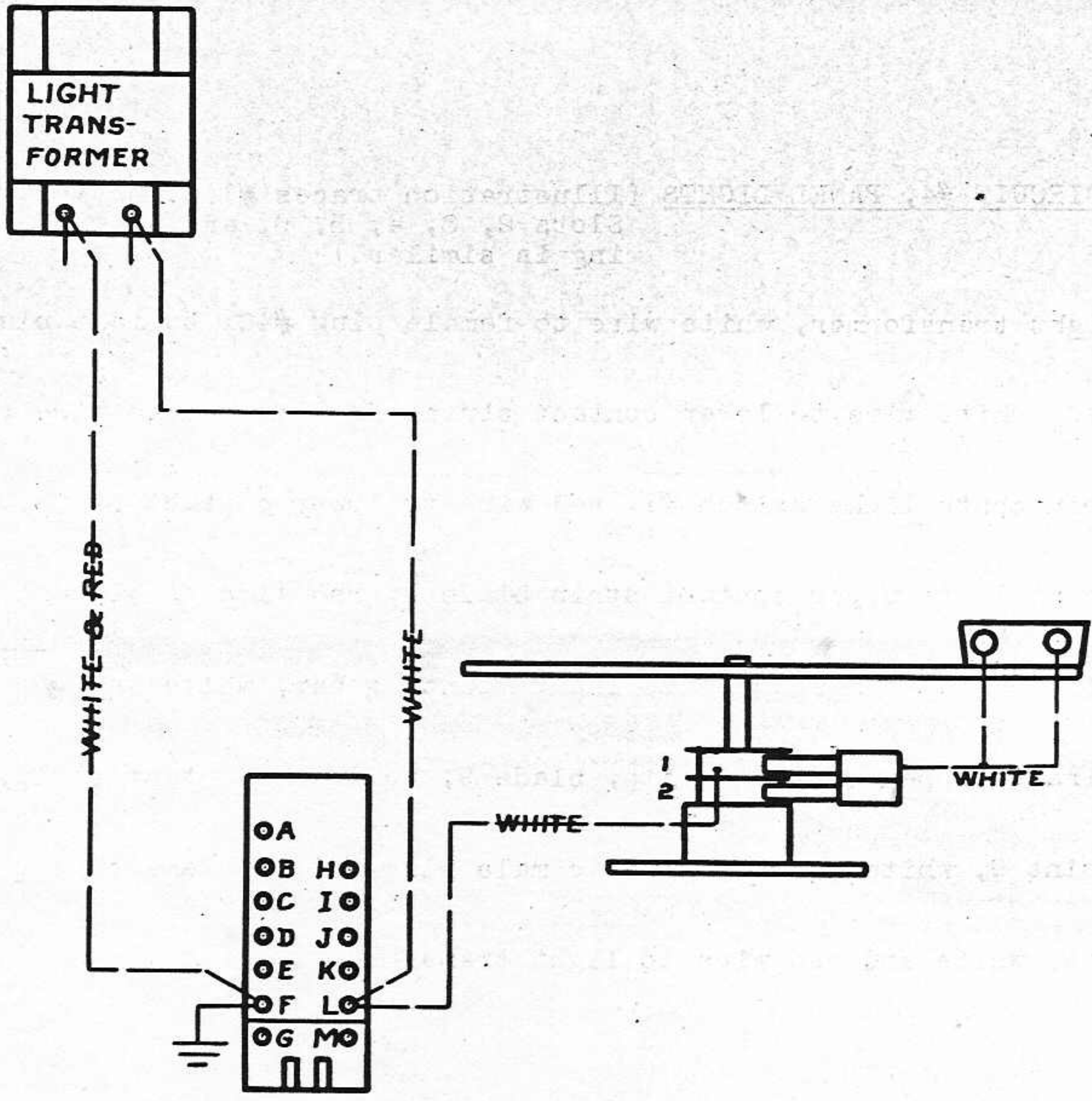

PLUG #5

CIRCUIT # 3
SPINNER LIGHTS
 8-24-1938

CIRCUIT #4, PANEL LIGHTS (Illustration traces #1 coin slot.
Slots 2, 3, 4, 5, 6, and 7, wiring is similar.)

Light transformer, white wire to female plug #4C, to male plug #4C, white wire to lower contact strip, point 8, white wire to coin chute light switch #1, red wire to lower contact strip, point 1, to upper contact strip blade 1, red wire to #1 panel light — grounded to light mounting bar, white and red wire to upper contact strip, blade 9, to lower contact strip, point 9, white and red wire to male plug #4A, to female plug #4A, white and red wire to light transformer.

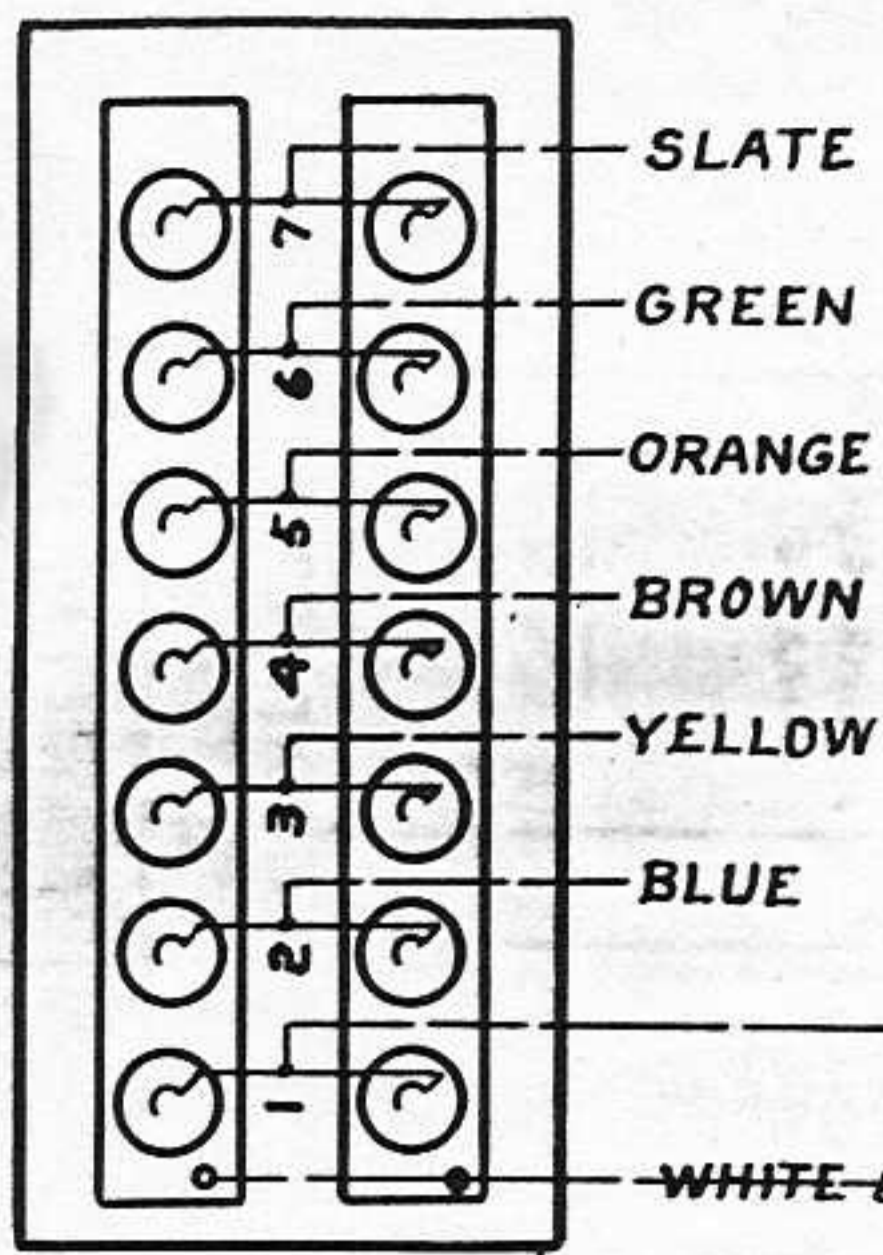

PANEL LIGHTS

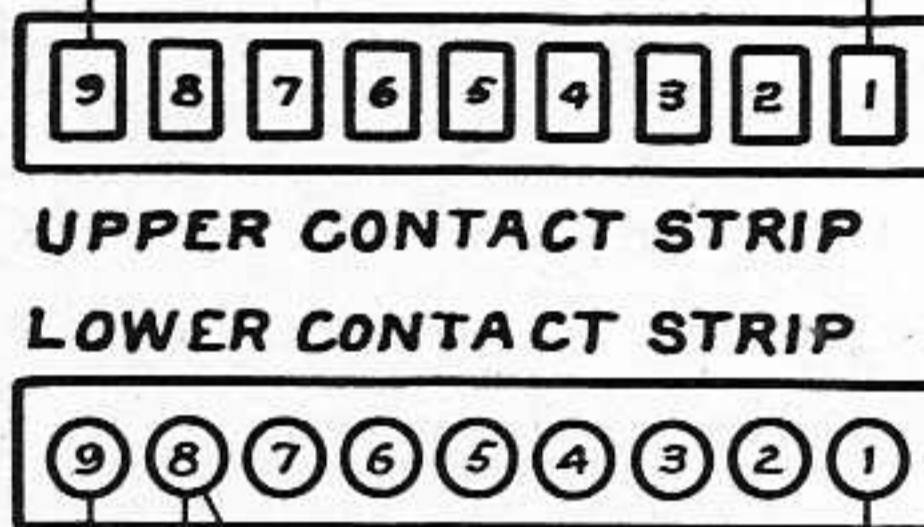

UPPER CONTACT STRIP

LOWER CONTACT STRIP

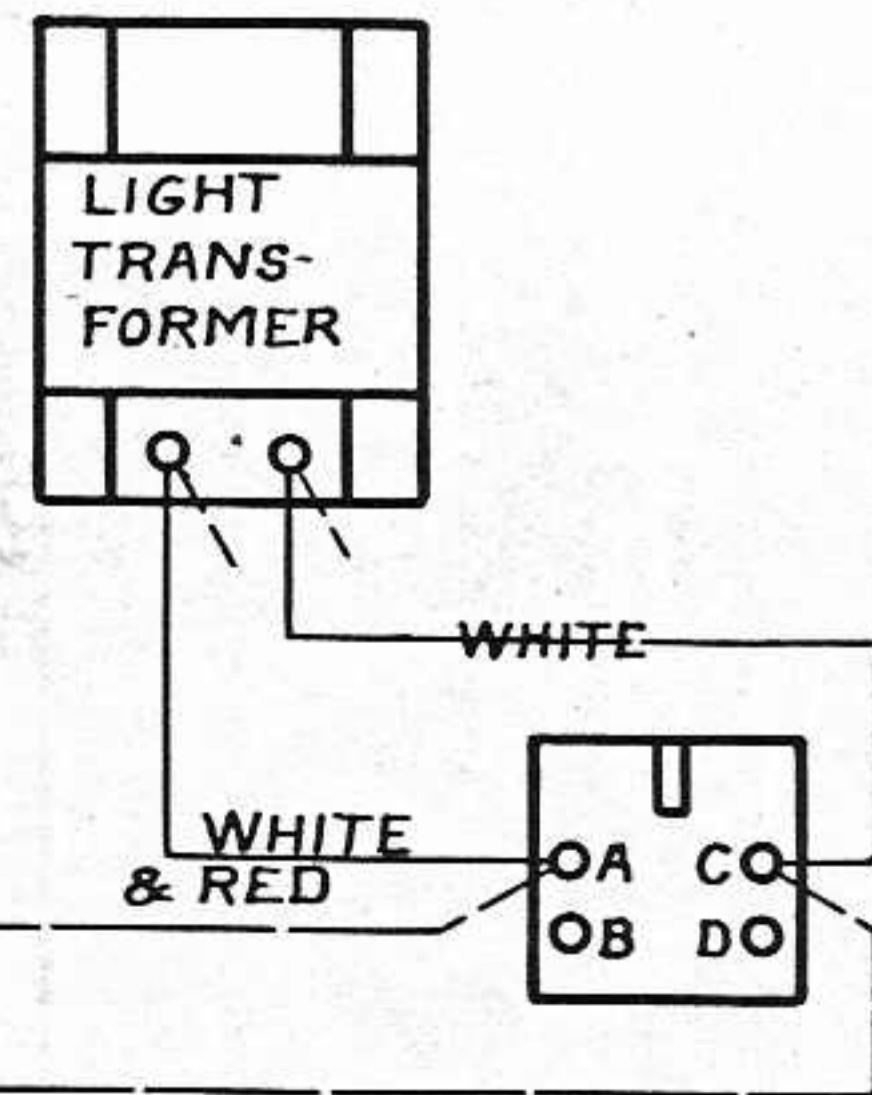
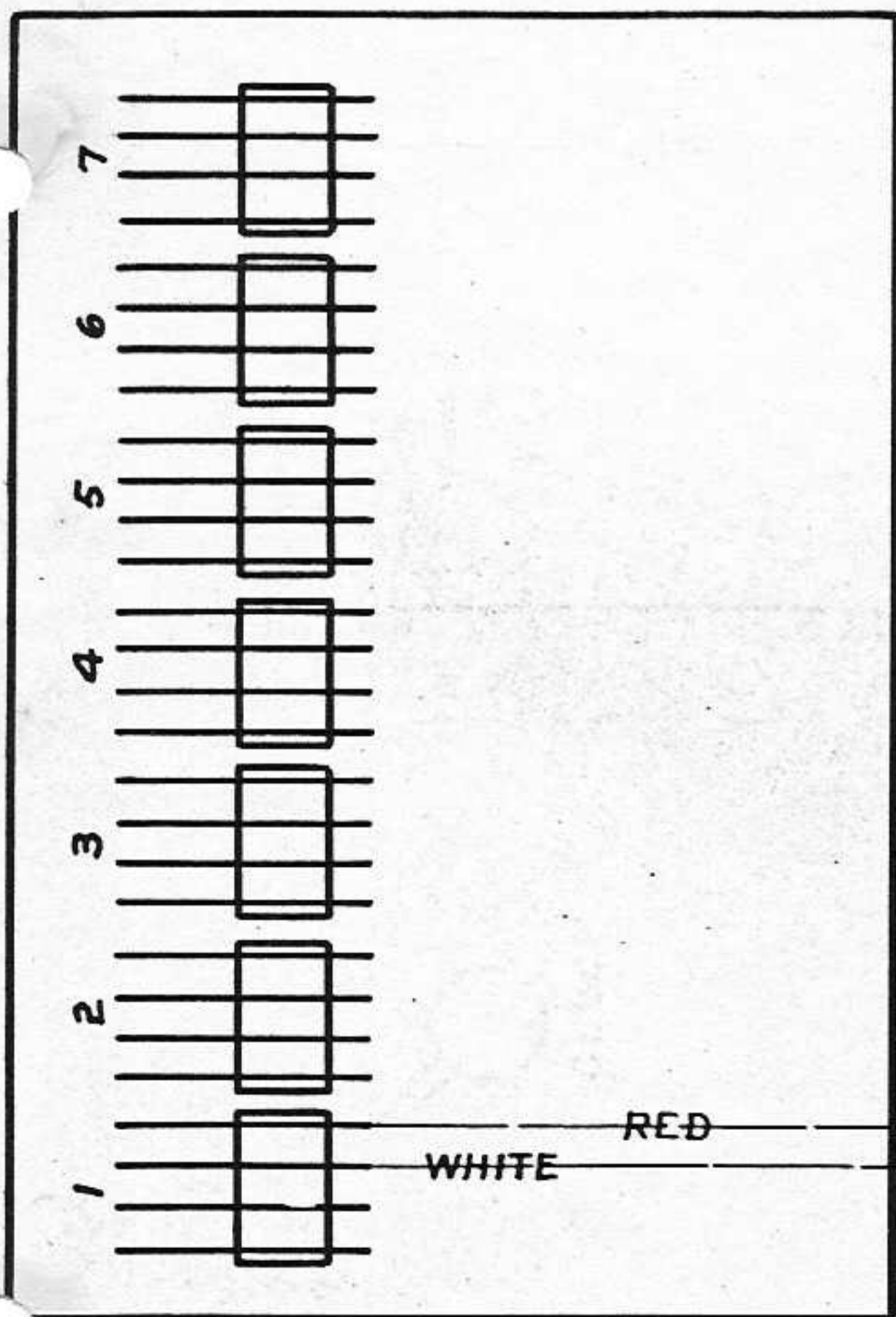

PLUG #4

CIRCUIT # 4
PANEL LIGHTS

8-24-1938

CIRCUIT #5, POWER TRANSFORMER

110 male plug, black wire to fuse #2, black wire to terminal
block #3A, black wire to female plug #3D, to male plug #3D,
black wire to clock switch, black wire to male plug #3H, to
female plug #3H, black wire to power transformer—————
black and white wire to terminal block #3B, black and white
wire to 110 male plug.

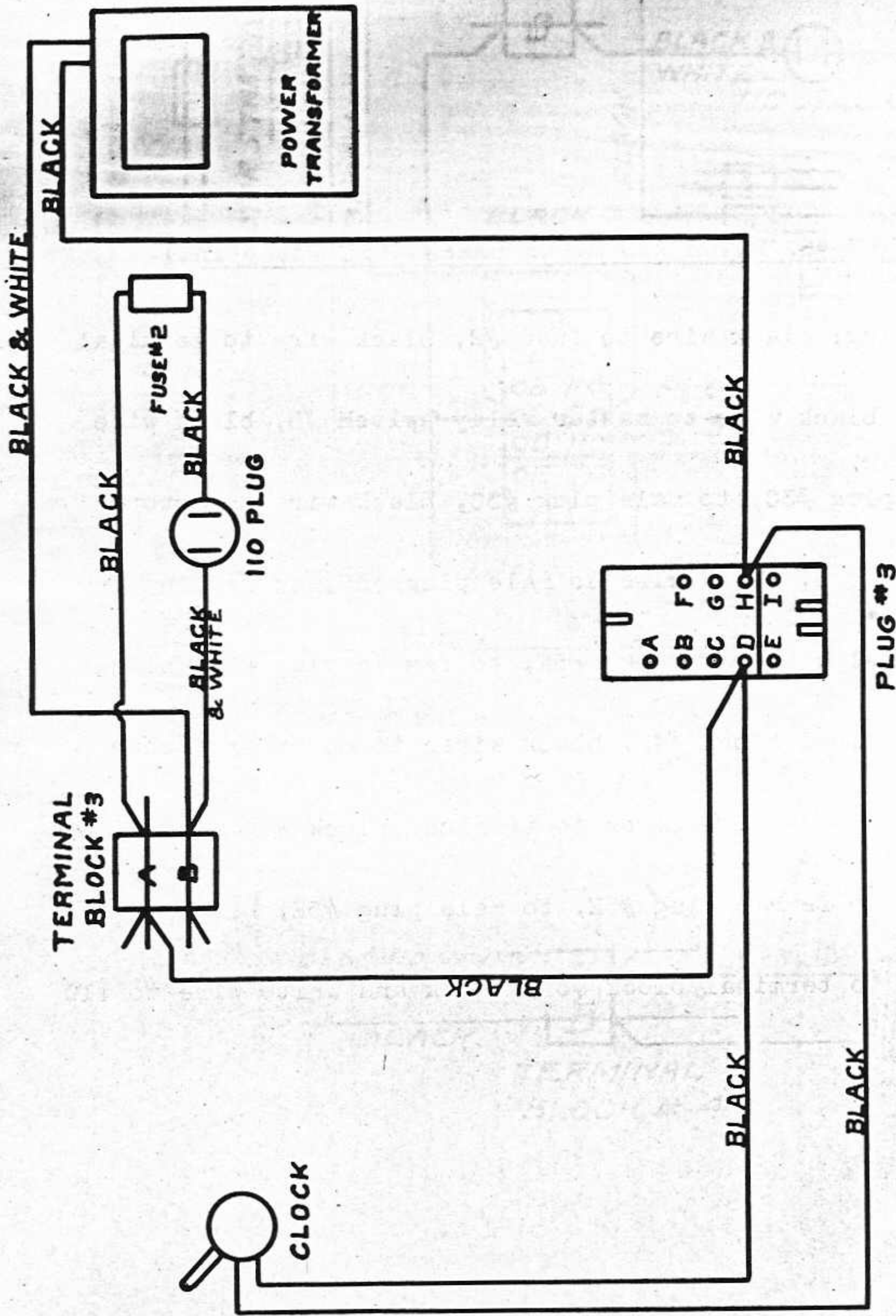

CIRCUIT #5
POWER TRANSFORMER
8-25-1938

CIRCUIT #6, MOTOR AND MOTOR BRAKE COIL (starting)

110 male plug; black wire to fuse #2, black wire to terminal block #3A, black wire to master relay switch #B, black wire to female plug #3C, to male plug #3C, black wire to motor starting switch, black wire to male plug #3G, to female plug #3G, black wire to male plug #5K, to female plug #5K, black wire to terminal block #4B, black wires to motor and motor brake coil——black wires to terminal block #4A, black and white wire to female plug #5E, to male plug #5E, black and white wire to terminal block #3B, black and white wire to 110 male plug.

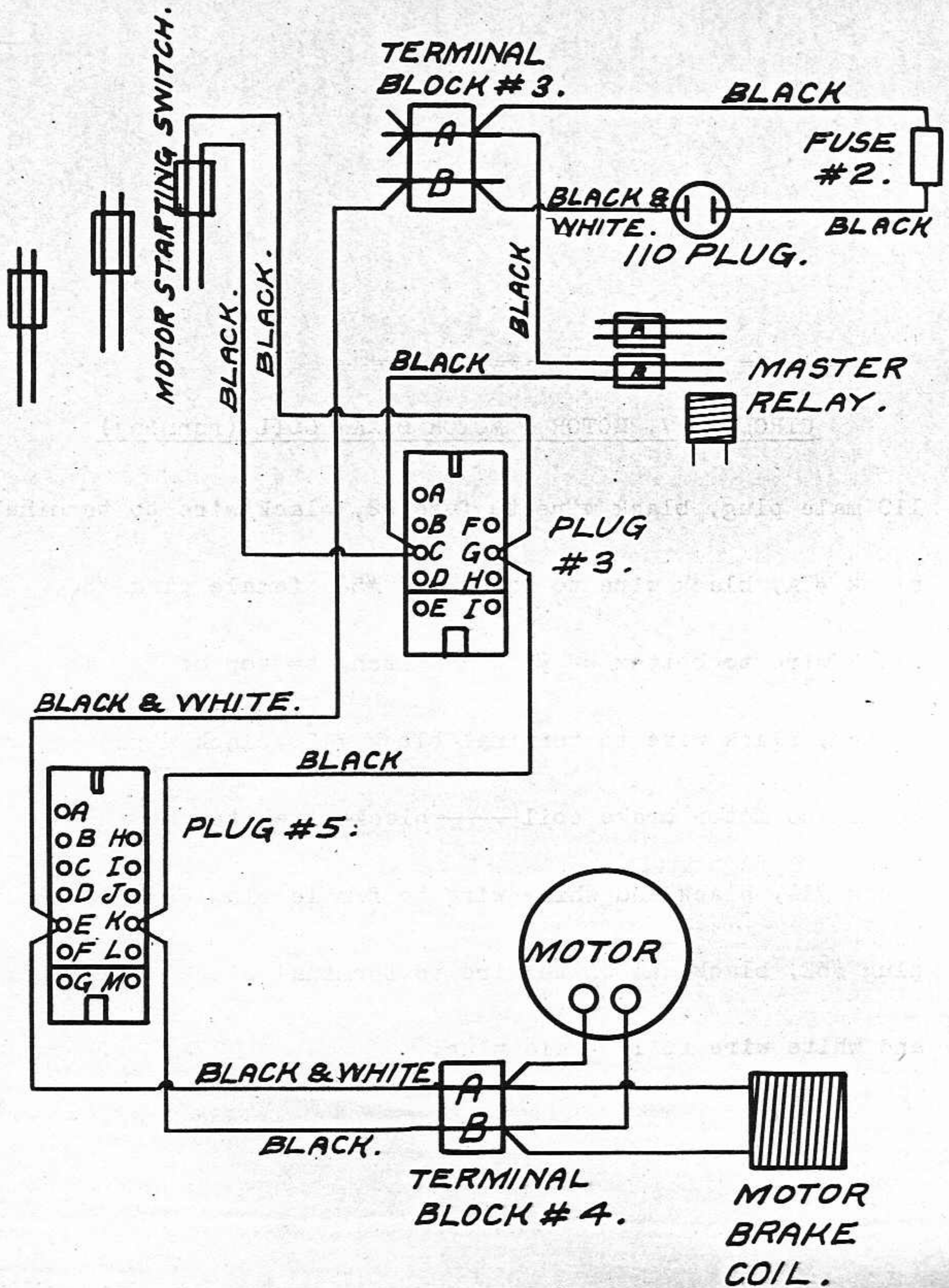

CIRCUIT #6.
MOTOR &
MOTOR BRAKE COIL.
(STARTING)

8-25-38

CIRCUIT #7, MOTOR & MOTOR BRAKE COIL (running)

110 male plug, black wire to fuse #2, black wire to terminal block #3A, black wire to male plug #5J, female plug #5J, black wire to bottom of #1 cam switch, to top of #1 cam switch, black wire to terminal block #4B, black wires to motor and motor brake coil——black wires to terminal block #4A, black and white wire to female plug #5E, to male plug #5E, black and white wire to terminal block #3B, black and white wire to 110 male plug.

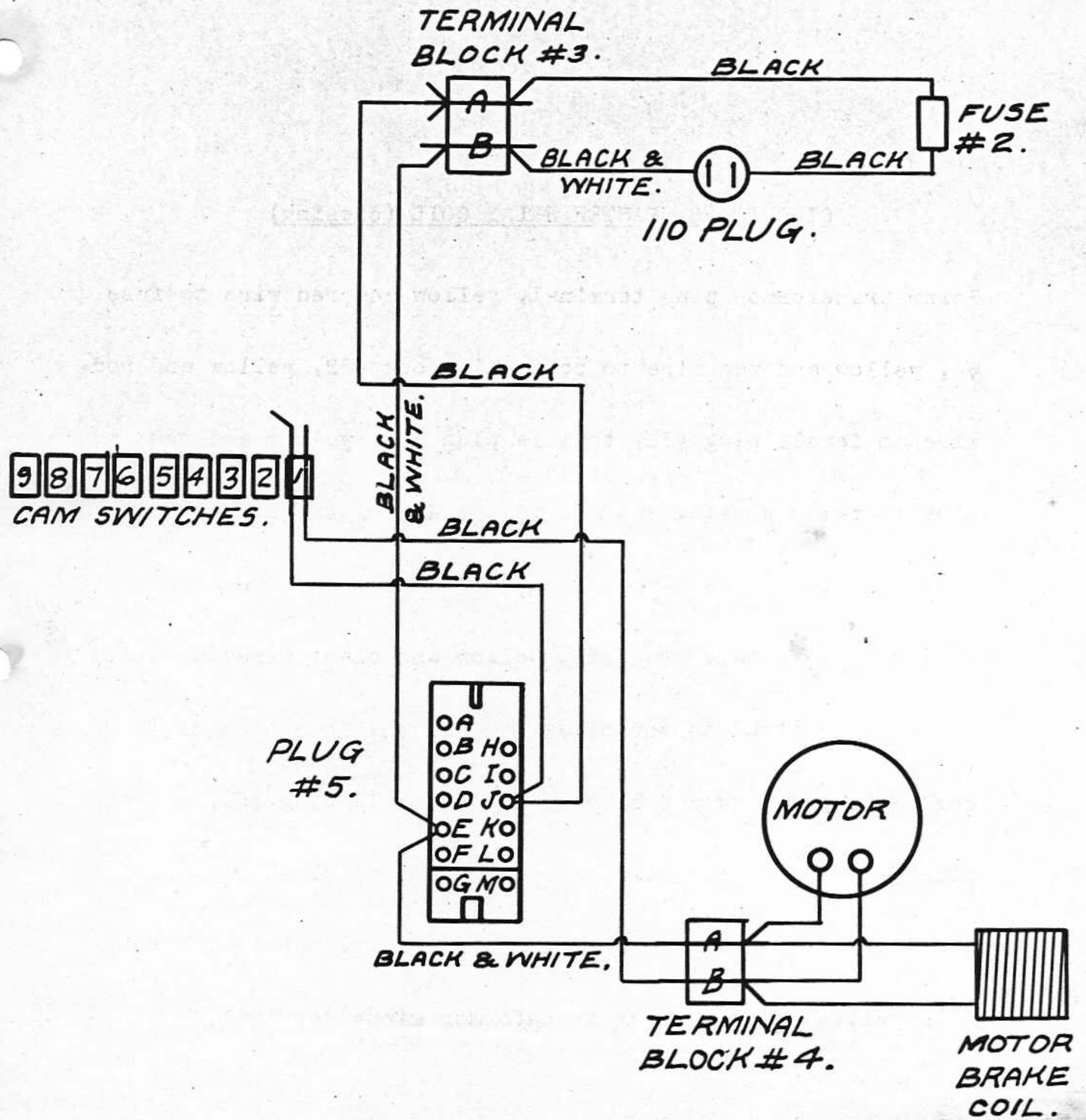

CIRCUIT #7.
 MOTOR &
 MOTOR BRAKE COIL.
 (RUNNING)

TERMINAL
BLOCK #3

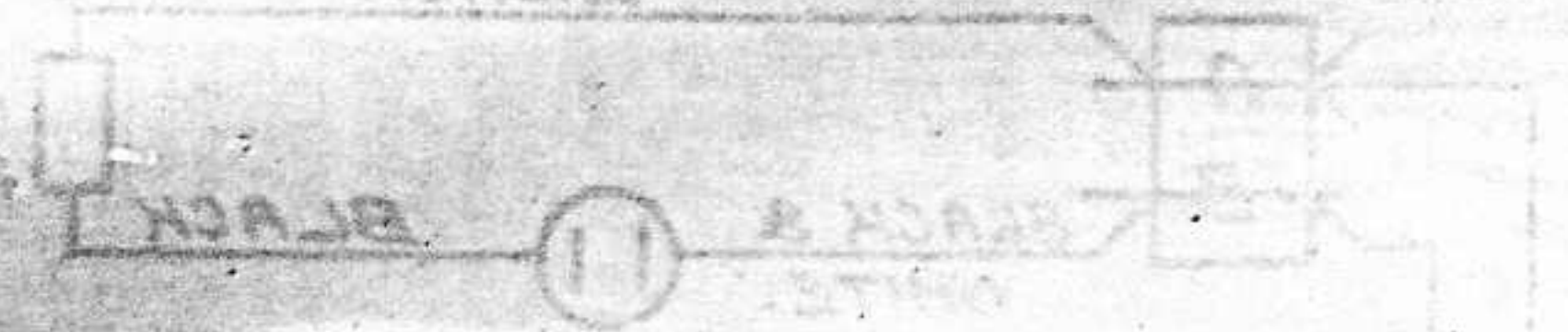

CIRCUIT #8, MASTER RELAY COIL (closing)

Power transformer plus terminal, yellow and red wire to fuse #3, yellow and red wire to terminal block #2B, yellow and red wire to female plug #3B, to male plug #3B, yellow and red wire to relay closing switch, yellow and black wire to male plug #3F, to female plug #3F, yellow and black wire to male plug #5B, to female plug #5B, yellow and black wire to bottom of #2 cam switch, to top of #2 cam switch, to bottom of #9 cam switch, yellow and black wire to female plug #5D, to male plug #5D, yellow and black wire to terminal block #2E, coil wire to master relay coil——coil wire to terminal block #2C, yellow wire to power transformer minus terminal,

CIRCUIT #8
MASTER RELAY COIL
(CLOSING)

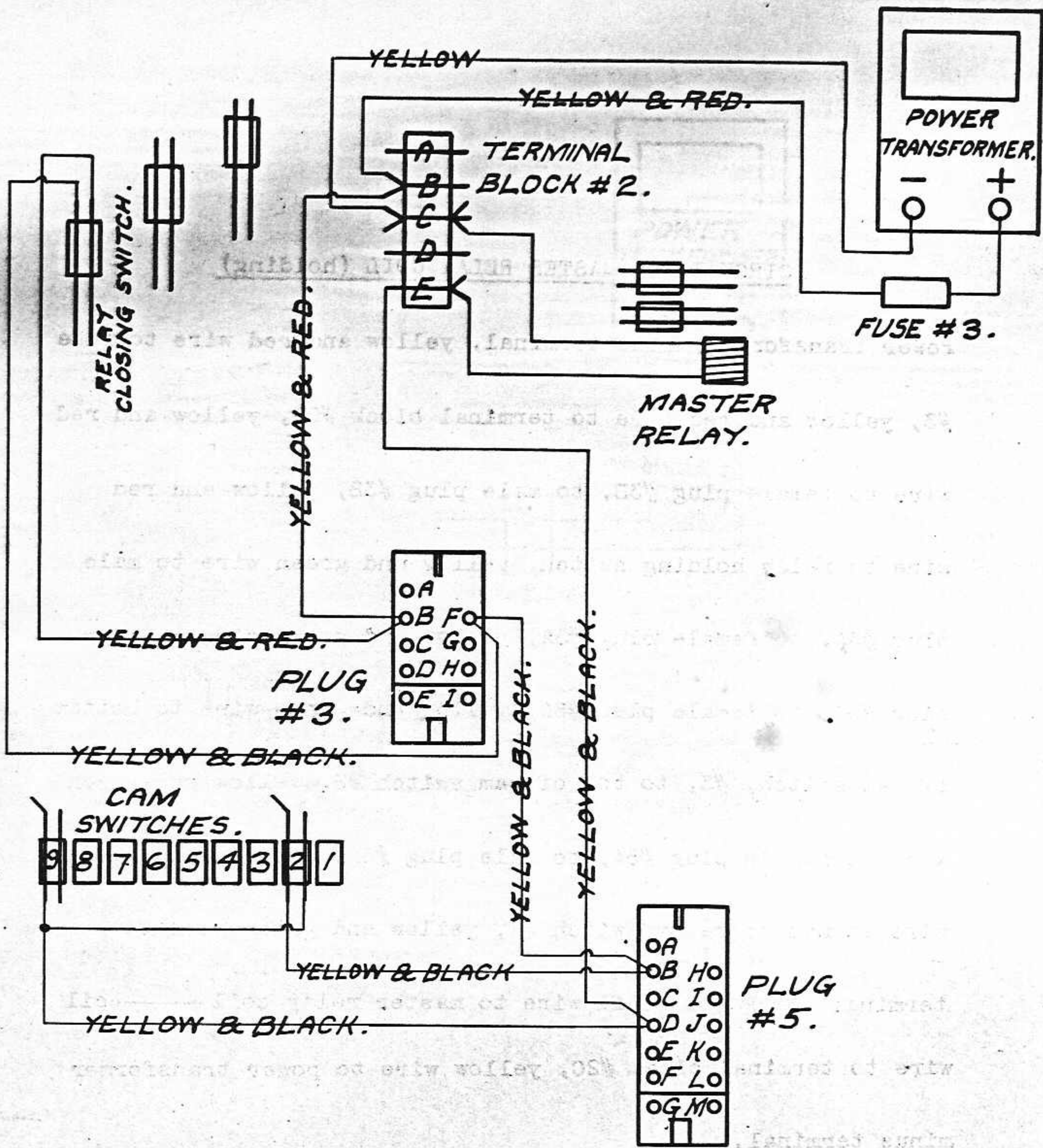

CIRCUIT #8.
MASTER RELAY COIL.
(CLOSING).

8-24-'38

CIRCUIT #9, MASTER RELAY COIL (holding)

Power transformer, plus terminal, yellow and red wire to fuse #3, yellow and red wire to terminal block #2B, yellow and red wire to female plug #3B, to male plug #3B, yellow and red wire to relay holding switch, yellow and green wire to male plug #3A, to female plug #3A, yellow and green wire to male plug #5C, to female plug #5C, yellow and green wire to bottom of cam switch, #3, to top of cam switch #3, yellow and green wire to female plug #5A, to male plug #5A, yellow and green wire to master relay switch #A, yellow and green wire to terminal block #2E, coil wire to master relay coil ——— coil wire to terminal block #2C, yellow wire to power transformer minus terminal.

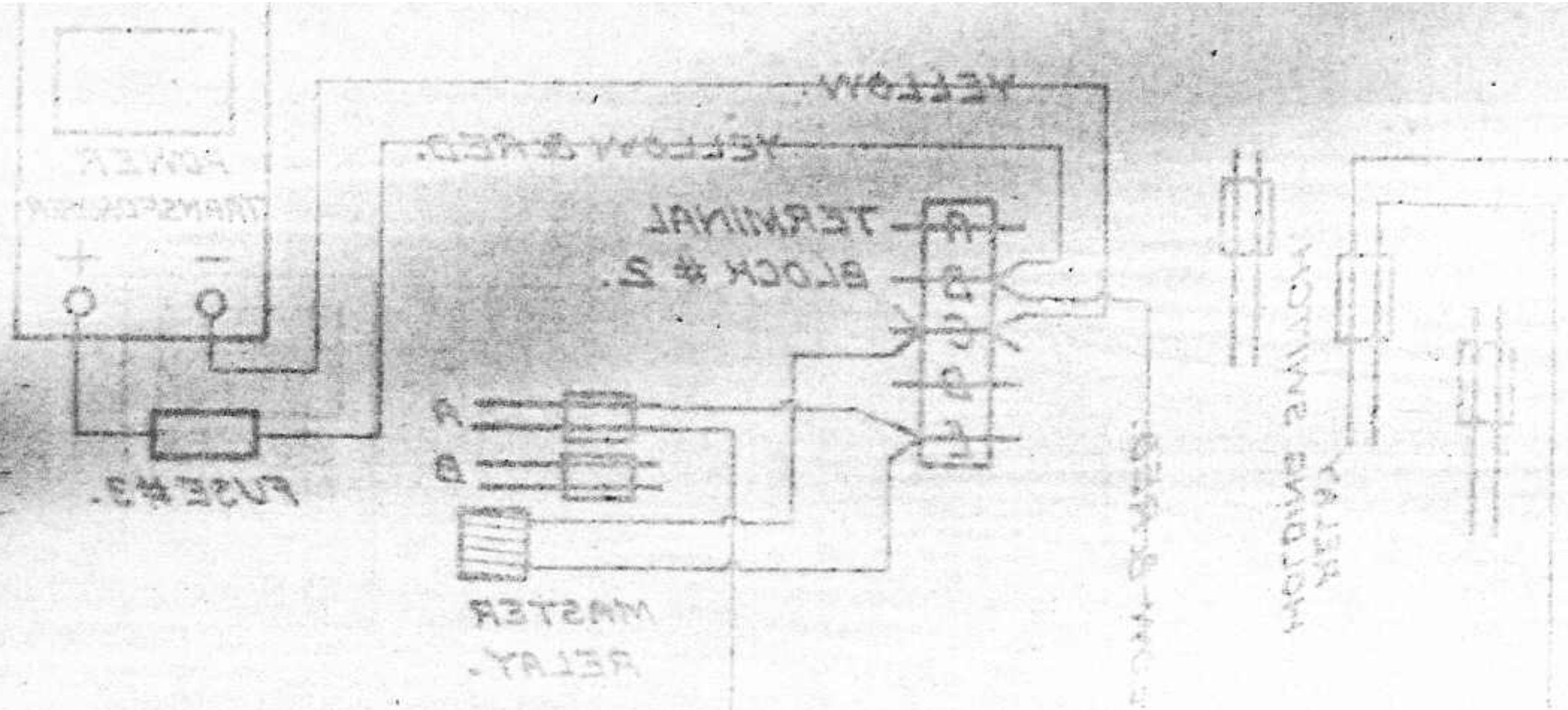

CIRCUIT #10, SPINNER CLUTCH COIL

Power transformer, plus terminal, yellow and red wire to female plug #7B, to male plug #7B, yellow and red wire to bottom of cam switch #4, to top of cam switch #4, green wire to spinner clutch coil——yellow wire to male plug #7A, to female plug #7A, yellow wire to power transformer minus terminal.

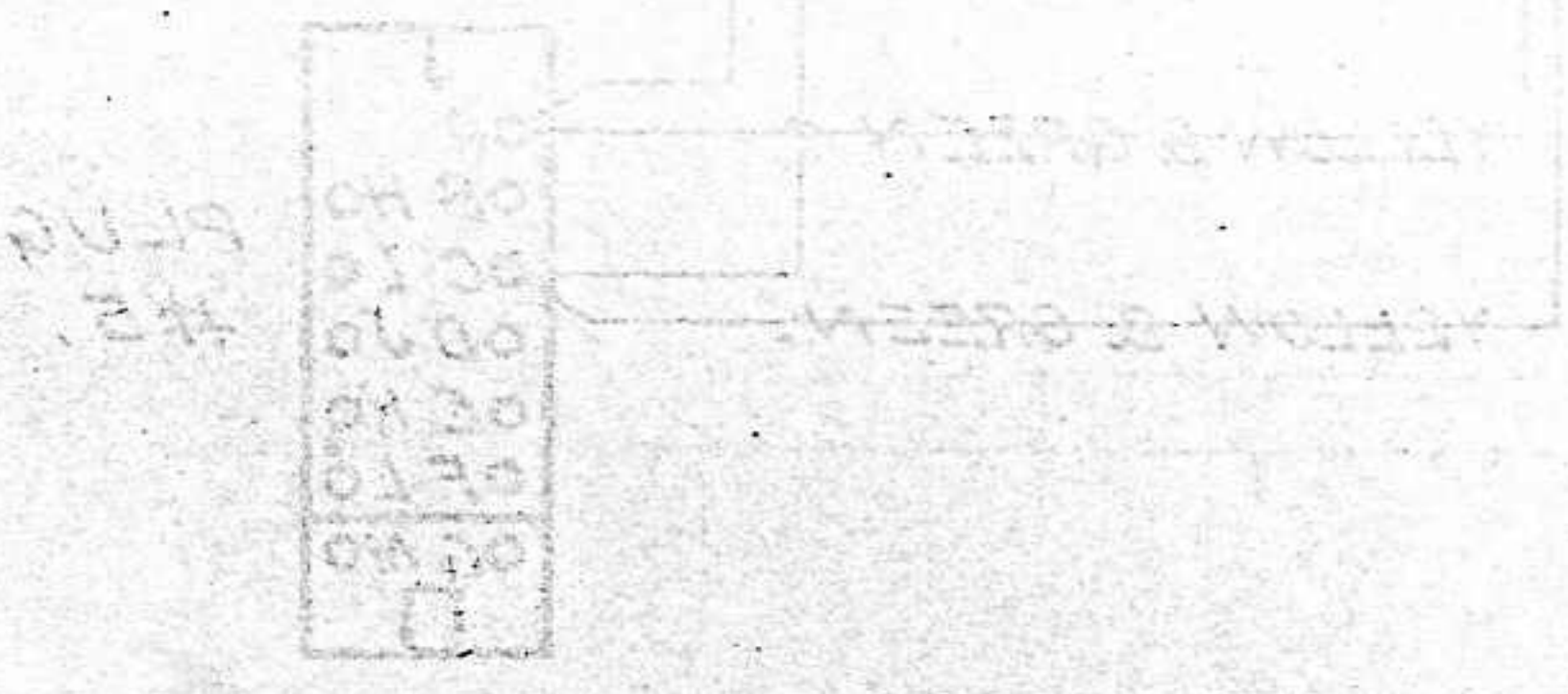

CIRCUIT # 9
 MASTER RELAY COIL
 (GROUNDING)

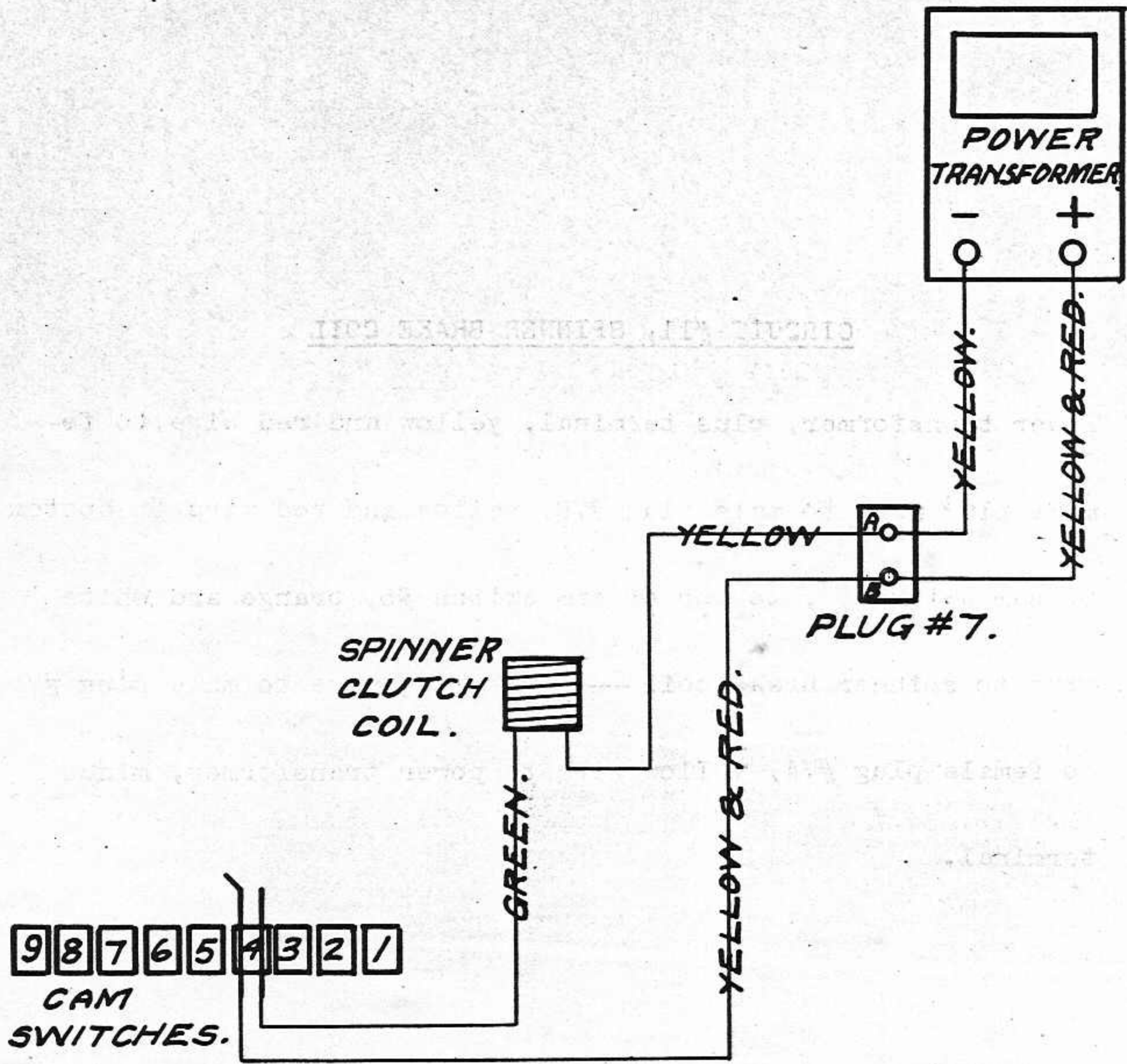

CIRCUIT #10 SPINNER CLUTCH COIL

CIRCUIT #10
SPINNER CLUTCH COIL.
8-24-38.



CIRCUIT #11, SPINNER BRAKE COIL

Power transformer, plus terminal, yellow and red wire, to female plug #7B, to male plug #7B, yellow and red wire to bottom of cam switch #5, to top of cam switch #5, orange and white wire to spinner brake coil ——— yellow wire to male plug #7A, to female plug #7A, yellow wire to power transformer, minus terminal.



CIRCUIT #11
SPINNER BRAKE COIL

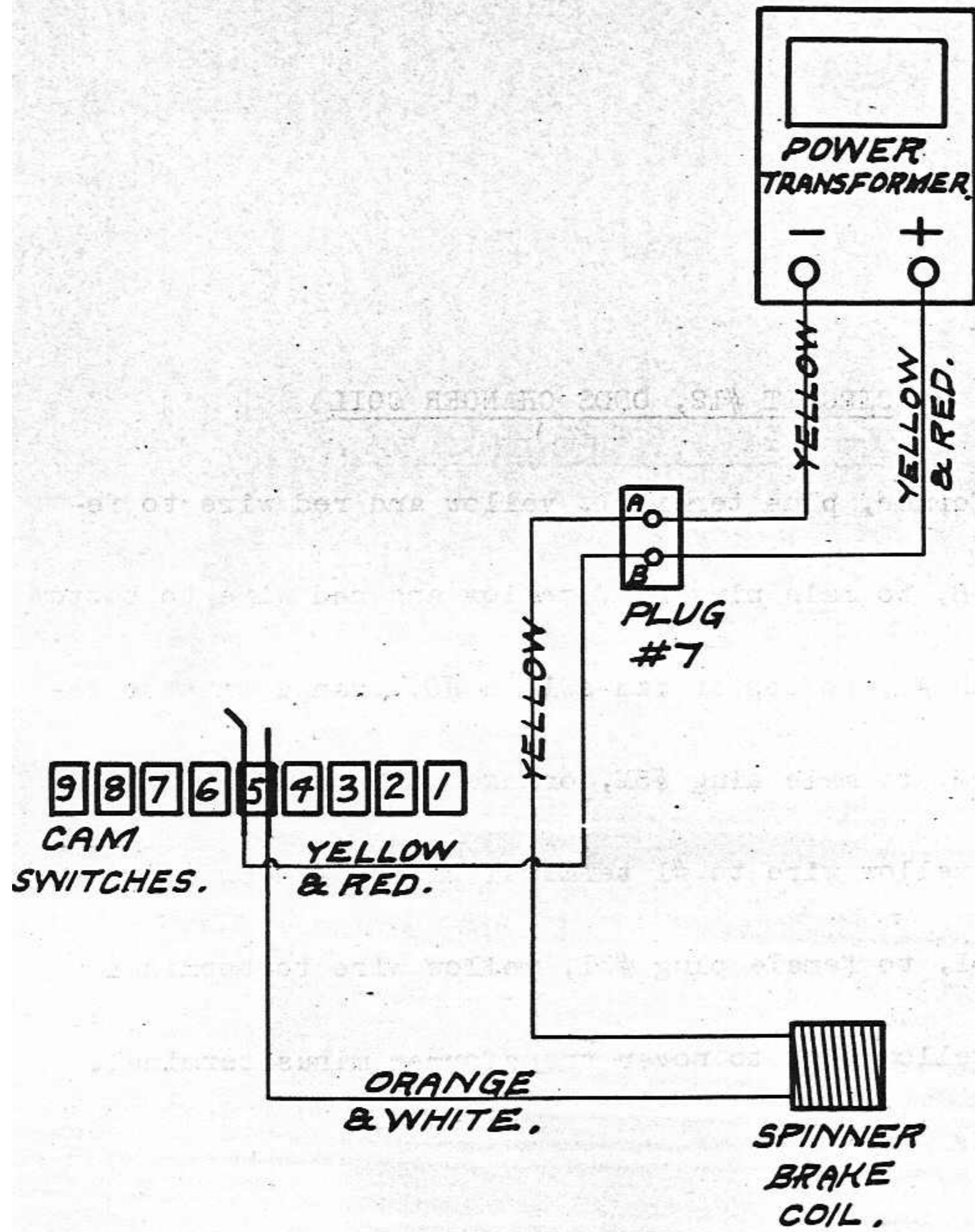

CIRCUIT #11.
SPINNER BRAKE COIL.
8-24-38



CIRCUIT #12, ODDS CHANGER COIL

Power transformer, plus terminal, yellow and red wire to female plug #7B, to male plug #7B, yellow and red wire to bottom of cam switch #6, to top of cam switch #6, orange wire to female plug #5M, to male plug #5M, orange wire to odds changer coil——yellow wire to #1 terminal block, yellow wire to male plug #3I, to female plug #3I, yellow wire to terminal block #2C, yellow wire to power transformer minus terminal.

CIRCUIT #11
SPINNER BRAKE COIL
2-24-59

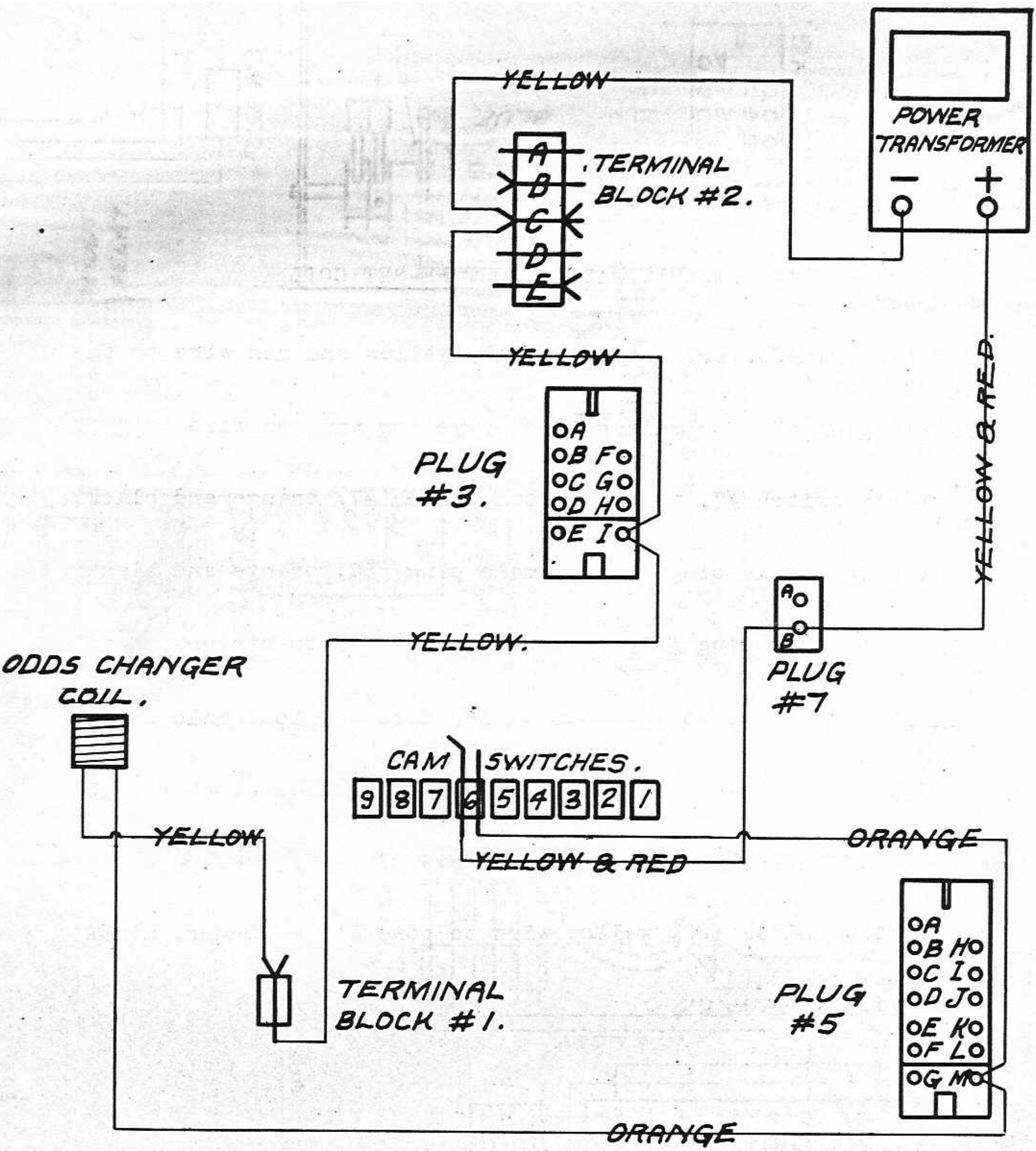

CIRCUIT #12
ODDS CHANGER COIL.
 8-24-38

CIRCUIT #13, PAYOUT RE-SET COIL

Power transformer, plus terminal, yellow and red wire to female plug #7B, to male plug #7B, yellow and red wire to bottom of cam switch #7, to top of cam switch #7, orange and black wire to female plug #5G, to male plug #5G, orange and black wire to male plug #1X, to female plug #1X, to binder post #D, to payout reset coil—to binder post #C, to female plug #1Y, to male plug #1Y, yellow wire to terminal block #1, yellow wire to male plug #3I, to female plug #3I, yellow wire to terminal block #2C, yellow wire to power transformer, minus terminal.

CIRCUIT #14, PAYOUT COIL THROUGH #8 CAM

(Illustration traces #1 coin slot and 16 payout. Other circuits through other coin slots and other payout numbers, are similar).

Power transformer, plus terminal, yellow and red wire to fuse #3, yellow and red wire to terminal block #2B, yellow and red wire to female plug #3B, to male plug #3B, yellow and red wire to relay holding switch, yellow and green wire to male plug #3A, to female plug #3A, yellow and green wire to male plug #5C, to female plug #5C, yellow and green wire to bottom of cam switch #3, to top of cam switch #3, yellow and green wire to female plug #5A, to male plug #5A, yellow and green wire to master relay switch #A, yellow and green wire to terminal block #2E, yellow and black wire to female plug #5D, to male plug #5D, yellow and black wire, to bottom of #9 cam switch, to bottom of cam switch #8, to top of cam switch #8, green and white wire to spinner ring #2, to spinner brushes #2, to spinner commutator brush, to spinner commutator point #1, red wire to female plug #6-1, to male plug #6-1, red wire to coin chute switch #1, red and white wire to male plug #2-1, to female plug #2-1, red and white wire to odds changer commutator brush #1, to odds changer commutator point #16, to collector ring #16, to collector ring brush #16, orange wire to male plug #1-16, to female plug #1-16, to payout unit commutator points #16, to payout unit commutator brush, to oscillating switch brush, to bottom of oscillating switch, to top of oscillating switch, to binder post #B, to payout coil——— to binder post #C, to female plug #1Y, to male plug #1Y, yellow wire to terminal block #1, yellow wire to male plug #3I, to female plug #3I, yellow wire to terminal block #2C, yellow wire to power transformer, minus terminal.

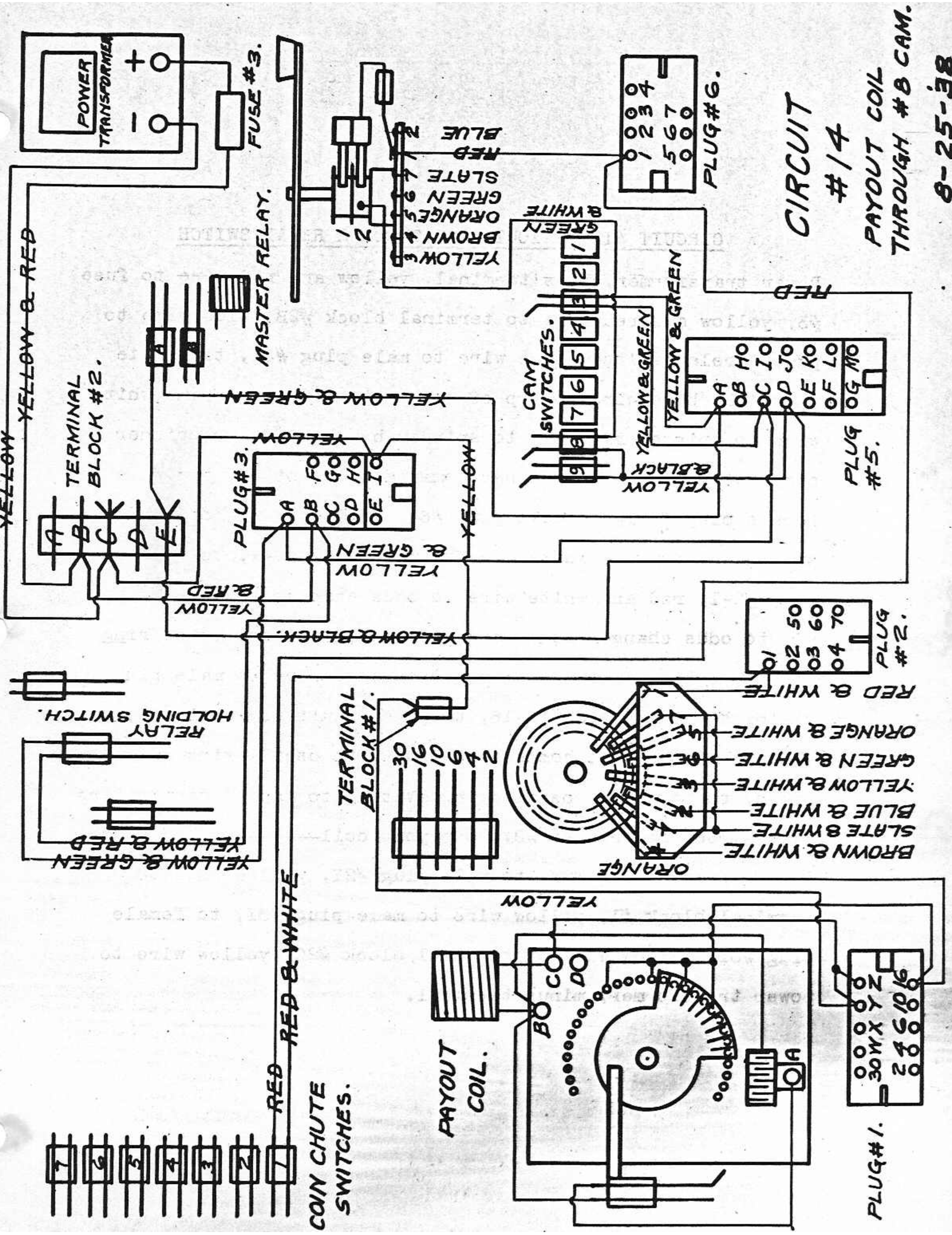

CIRCUIT #14
PAYOUT COIL THROUGH #8 CAM.

8-25-38

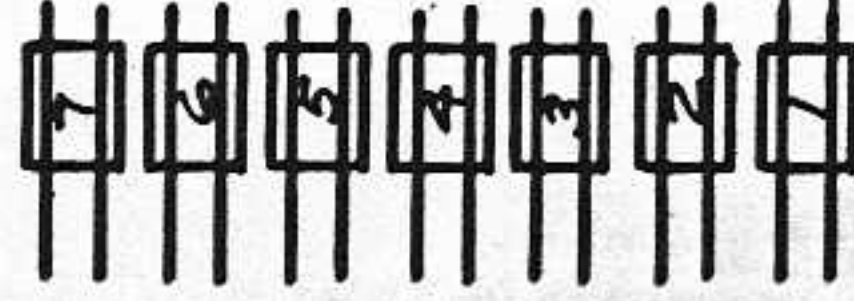

COIN CHUTE SWITCHES.

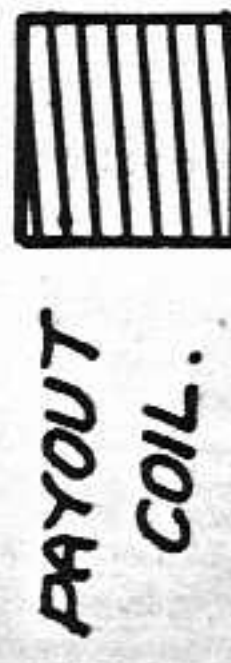

PAYOUT COIL.

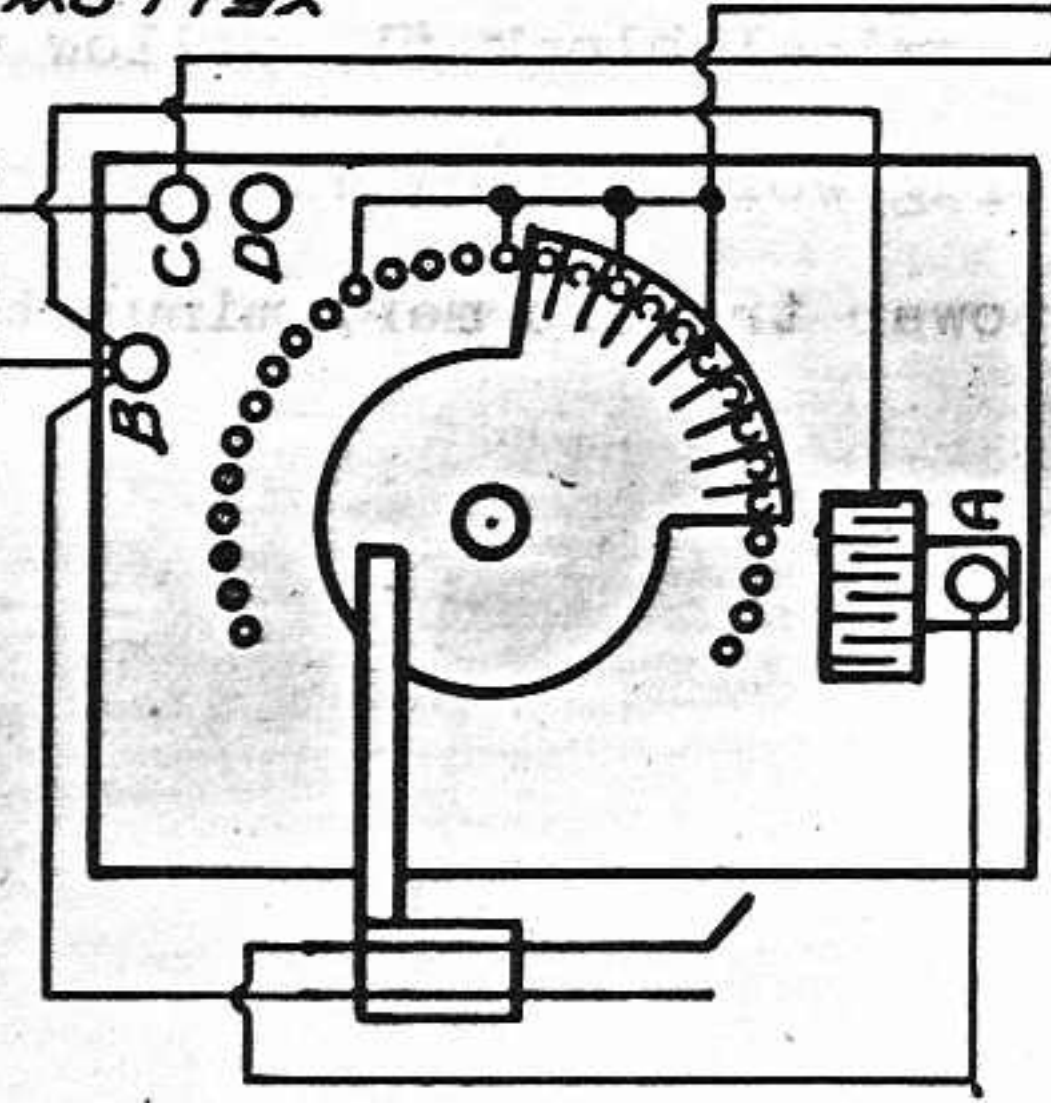

PLUG #1.

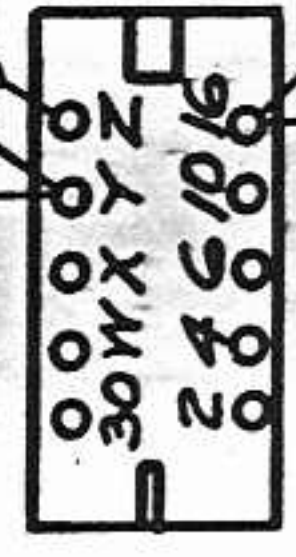

TERMINAL BLOCK #1.

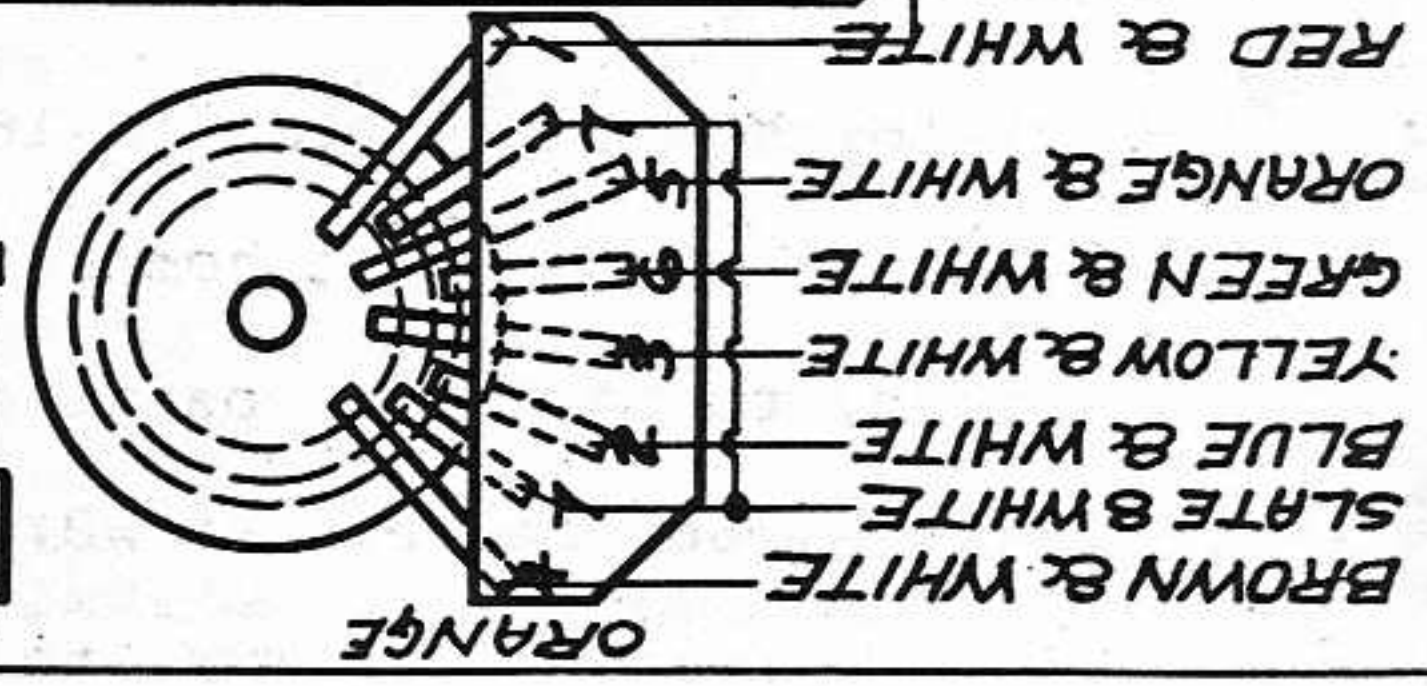
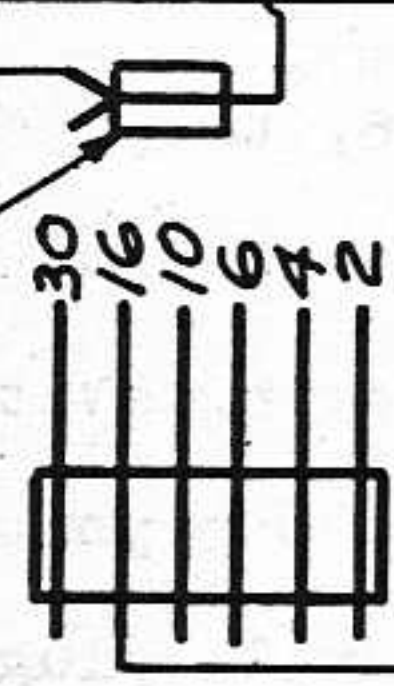

TERMINAL BLOCK #2.

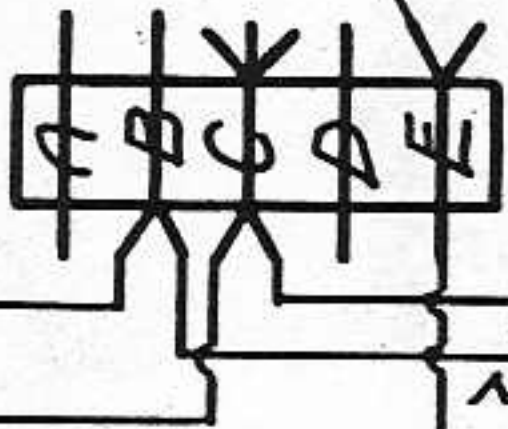

PLUG #3.

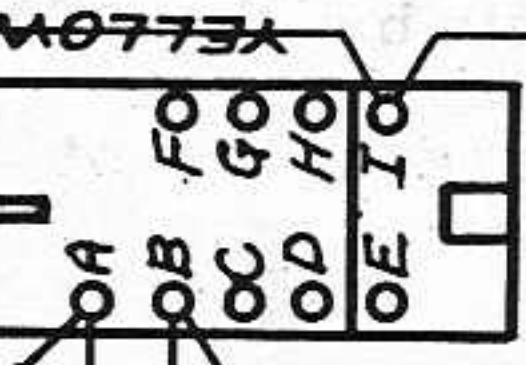

PLUG #2.

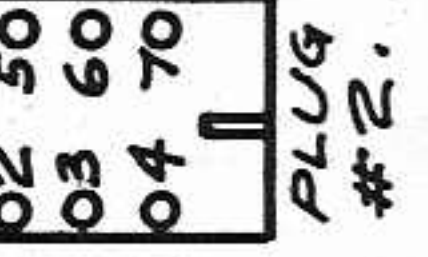

PLUG #5.

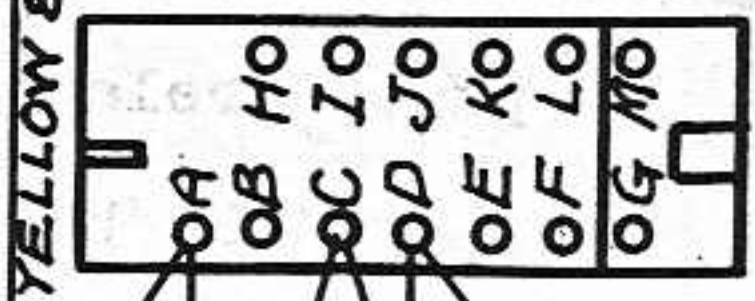

CAM SWITCHES.

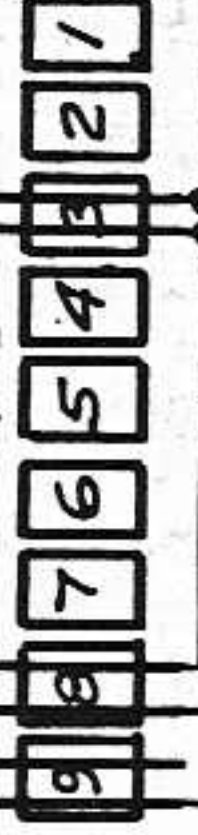

PLUG #6.

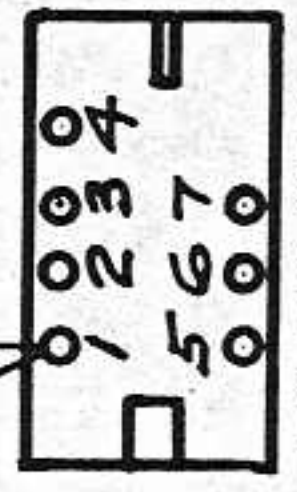

MASTER RELAY.

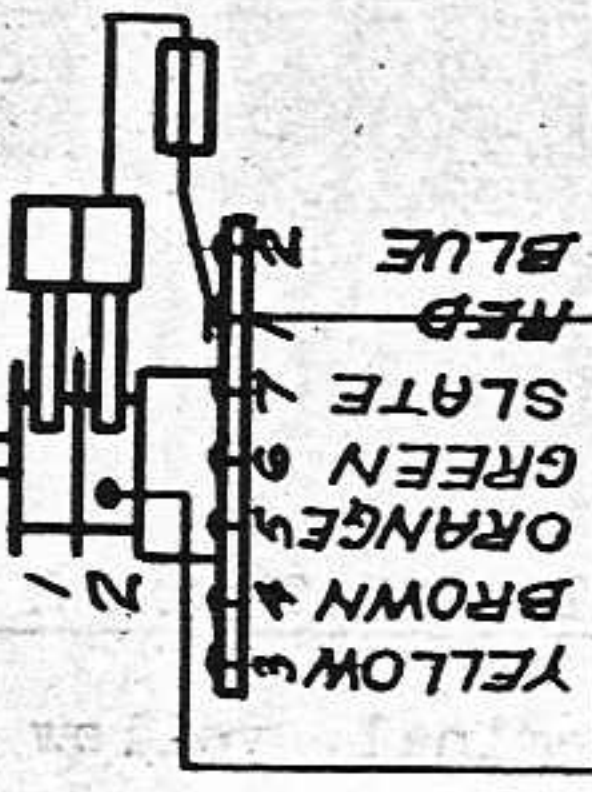

POWER TRANSFORMER

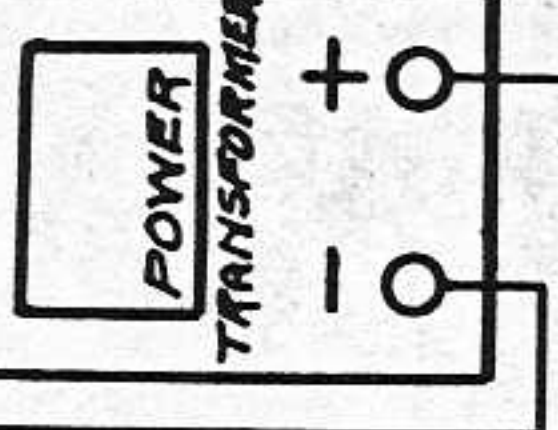

FUSE #3.

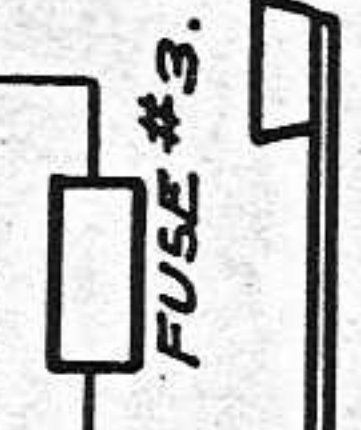

CIRCUIT #15, PAYOUT COIL THROUGH RELAY SWITCH

Power transformer, plus terminal, yellow and red wire to fuse #3, yellow and red wire to terminal block #2B, blue wire to payout relay switch, blue wire to male plug #5H, to female plug #5H, blue wire to top of cam switch #8, green and white wire to spinner ring #2, to spinner brushes #2, to spinner commutator brush, to spinner commutator point #1, red wire to female plug #6-1, to male plug #6-1, red wire to coin chute switch #1, red and white wire to male plug #2-1, to female plug #2-1, red and white wire to odds changer commutator brush #1, to odds changer commutator point #16, to collector ring #16, to collector ring brush #16, orange wire to male plug #1-16, to female plug #1-16, to payout unit commutator points #16, to payout unit commutator brush, to oscillating switch brush, to bottom of oscillating switch, to top of oscillating switch, to binder post #B, to payout coil——to binder post #C, to female plug #2Y, to male plug #2Y, yellow wire to terminal block #1, yellow wire to male plug #3I, to female plug #3I, yellow wire to terminal block #2C, yellow wire to power transformer, minus terminal.

CIRCUIT #16, PAYOUT RELAY COIL

Power transformer, plus terminal, yellow and red wire to fuse #3, yellow and red wire to terminal block #2B, yellow and red wire to female plug #3B, to male plug #3B, yellow and red wire to relay holding switch, yellow and green wire to male plug #3A, to female plug #3A, yellow and green wire to male plug #5C, to female plug #5C, yellow and green wire to bottom of cam switch #3, to top of cam switch #3, yellow and green wire to female plug #5A, to male plug #5A, yellow and green wire to master relay switch #A, yellow and green wire to terminal block #2E, yellow and black wire to male plug #5D, to female plug #5D, yellow and black wire to bottom of cam switch #9, to bottom of cam switch #8, to top of cam switch #8, green and white wire to spinner ring #2, to spinner brushes #2, to spinner commutator brush, to spinner commutator point #1, red wire to female plug #6-1, to male plug #6-1, red wire to coin chute switch #1, red and white wire to male plug #2-1, to female plug #2-1, red and white wire to odds changer commutator brush #1, to odds changer commutator point #16, to collector ring #16, to collector ring brush #16, orange wire to male plug #1-16, to female plug #1-16, to payout unit commutator points #16, to payout unit commutator brush, to oscillating switch brush, to bottom of oscillating switch, to binder post #A, to female plug #1W, to male plug #1W, red and white wire to male plug #3E, to female plug #3E, red and white wire to terminal block #2D, coil wire to payout relay coil——coil wire to terminal block #2C, yellow wire to power transformer, minus terminal.

CIRCUIT #17, RELAY BOOSTER COIL

Power transformer, plus terminal, yellow and red wire to fuse #3, yellow and red wire to terminal block #2B, yellow and red wire to female plug #3B, to male plug #3B, yellow and red wire to relay holding switch, yellow and green wire to male plug #3A, to female plug #3A, yellow and green wire to male plug #5C, to female plug #5C, yellow and green wire to bottom of cam switch #3, to top of cam switch #3, yellow and green wire to female plug #5A, to male plug #5A, yellow and green wire to master relay switch #A, yellow and green wire to terminal block #2E, yellow and black wire to male plug #5D, to female plug #5D, yellow and black wire to bottom of cam switch #9, to top of cam switch #9, red wire to female plug #5I, to male plug #5I, red wire to terminal block #2A, coil wire to relay booster coil——coil wire to terminal block #2C, yellow wire to power transformer, minus terminal.

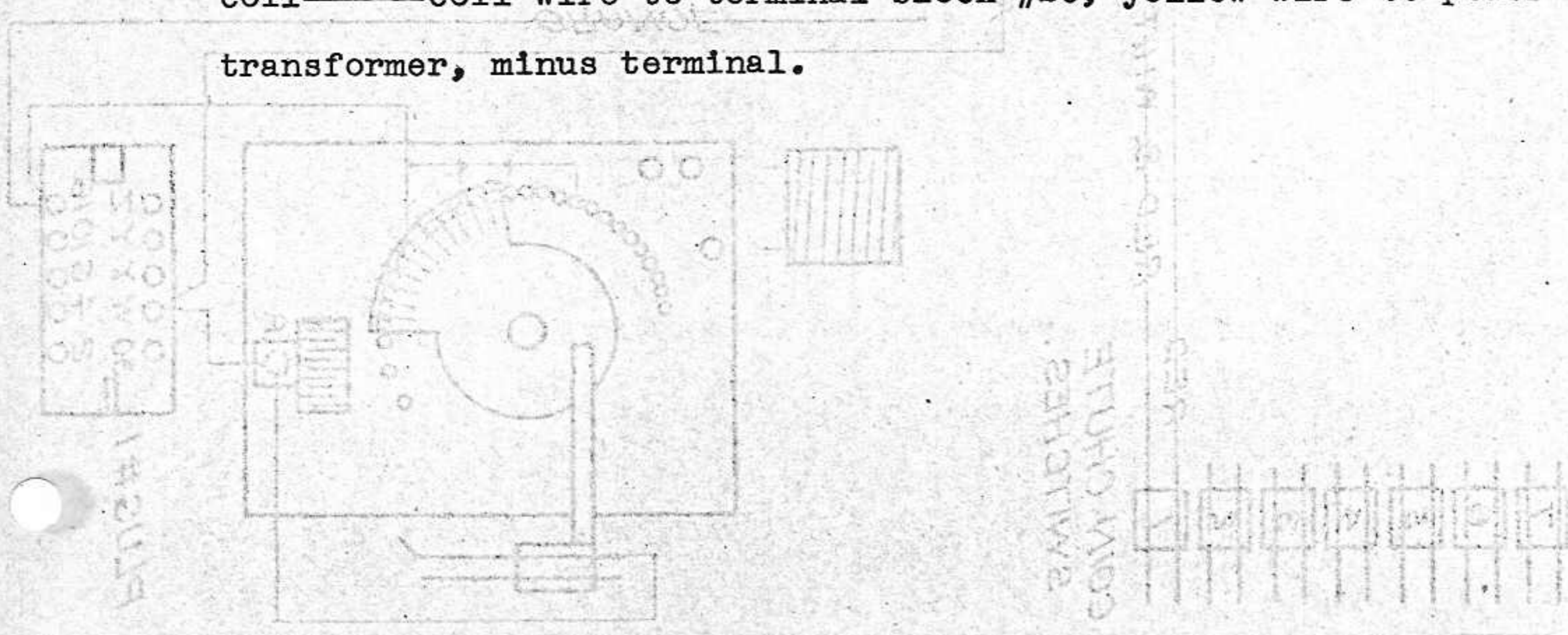

INDEX to CIRCUITS

COILS

Master Relay (Closing) - - - - -	#8
Master Relay (Holding) - - - - -	#9
Motor and Motor Brake (Starting) - - - - -	#6
Motor and Motor Brake (Running) - - - - -	#7
Odds Changer - - - - -	#12
Payout (Through #8 cam) - - - - -	#14
Payout (Through Payout Relay) - - - - -	#15
Payout Relay - - - - -	#16
Payout Reset - - - - -	#13
Relay Booster - - - - -	#17
Spinner Brake - - - - -	#11
Spinner Clutch - - - - -	#10

LIGHTS

Odds Changer - - - - -	#2
Panel - - - - -	#4
Spinner - - - - -	#3

TRANSFORMERS

Light - - - - -	#1
Power - - - - -	#5

Price List

BUCKLEY CONSOLE REPAIR PARTS

All repair parts will be shipped same day order is received. In the event of a delay in your shipment, you will be notified.

Our terms are cash with order for all repair parts.

Therefore, please remit cash, cashier's check, money order or stamps in order to save time in the delivery of repair parts since prompt service means so much to operators when their machines are out of service.

MAIN PARTS AND ASSEMBLIES

Steel Cabinet with door	\$ 40.00
Converter (300 Watts) for direct current locations	40.00
Multiple coin chute complete, with housing and base	40.00
" " " without " " "	30.00
Spinner assembly complete	35.00
Odds changer complete	25.00
Tuf-flex glass	25.00
Paymaster payout unit complete	20.00
Power pack, large 3 point combination	15.00
Remote control, complete with payout door and lock	12.50
Motor complete, with reduction	12.50
Operators tool kit	10.00
Quilt cover, made to order	9.00
No value amusement checks, per thousand	9.00
Wood shipping box	6.00
Light transformer	5.00
Striped stainless steel moulding	4.00
Horse Ornament (c-9-5)	3.50
Veeder register	2.50
Cabinet leveling legs, each (C-6-5)	2.00
Bell ornament (C-10-5)	2.00
Dice ornament	1.50
Cashiers window	1.50
Cashiers door75
Vacumn pump	1.50
Condenser	1.50
Rubber covered cable	1.50
Odds changer coil	1.50
Payout coil (large)	1.50
Spinner brake coil	1.50
Spinner clutch coil	1.50
Motor brake coil	1.50
Master relay coil	1.50
Payout relay coil	1.50
Payout booster coil	1.50
Payout reset coil75
Contact switch (S-32-S)35
Plugs and sockets, all types per set25
Bulb sockets10
Bulbs06
Special handles to carry machine, per set	1.00
Glass for coin chute housing75

SPINNER

Castings:

C-1-S	Spinner bracket base	\$3.50
C-2-S	Spinner bracket	3.50
C-14-S	Spinner clutch driving disc	2.00

Punch Press:

P-1-SS	Light spinner arm	1.00
P-2-SS	" " lamp reflector body	.50
P-6-SS	" " ratchet brake arm	.50
P-7-SS	" " clutch thrust hard washer	N/C
P-8-SS	" " friction disc	.50
P-9-SS	" " collector ring and commutator brush holder	.50
P-10-SS	" " collector auxiliary brush holder	.50
P-11-SS	" " clutch shifter arm	.50
P-12-SS	" " collector ring insulator collar	.25
P-13-SS	" " collector ring insulating separator	.25
P-14-SS	" " centering ratchet	1.50
P-16-SS	" " ratchet brake shoe	.50
P-18-SS	" " shaft thrust soft washer	N/C
P-19-SS	" " shaft thrust hard washer	N/C
P-22-SS	Spinner timing cam No. 1	.35
P-23-SS	" " " No. 2	.35
P-24-SS	" " " No. 3	.35
P-25-SS	" " " No. 4	.35
P-26-SS	" " " No. 5	.35
P-27-SS	" " " No. 6	.35
P-28-SS	" " " No. 7	.35
P-31-SS	" " " No. 8	.35
P-32-SS	" " " No. 9	.35
P-30-SS	Light Spinner centering ratchet for Riviera	1.50
P-33-SS	Spinner slotted washer	.25
P-34-SS	Light Spinner lamp reflector cover	.50
P-35-SS	Light spinner commutator (track odds)	3.00
P-38-SS	Motor brake armature bracket	.50
P-39-SS	Spinner plug mounting	1.00

Screw Machine:

M-1-SS	Light spinner shaft	.50
M-2-SS	" " arm counterweight	.50
M-3-SS	" " collector ring clamping collar	.50
M-4-SS	" " motor pulley	.50
M-5-SS	" " timing cam shaft clamping collar	.10
M-6-SS	" " bearing sleeve	.75
M-7-SS	" " lamp radial adjustment base	.75
M-8-SS	" " arm hub	.25
M-9-SS	" " collector ring	.50
M-10-SS	" " ratchet hub	.25

SPINNER (con't.)

Screw Machine (con't.)

M-11-SS	Light spinner timing cam shaft	\$.50
M-12-SS	" " timing cam end spacer25
M-13-SS	" " timing cam spacer25

Springs and Switches

S-4-S	Light spinner cam switch25
S-5-S	Light spinner commutator contact switch10
S-8-S	Spinner collector ring contact switch10
S-32-S	Light spinner cam switch (new style)35

ODDS CHANGER

Punch Press:

P-101-S0	Odds changer roller bearing thrust washer	N/C
P-102-S0	" " spinning pawl releasing finger50
P-103-S0	" " solenoid connecting rod50
P-104-S0	" " collector ring spacing washer50
P-105-S0	" " frame adjustable feet50
P-106-S0	" " collector ring end insulator	N/C
P-107-S0	" " collector ring insulating washer	N/C
P-108-S0	" " collector ring50
P-109-S0	" " commutator clamping plate50
P-110-S0	" " roller bearing sealing washer	N/C
P-111-S0	" " drum shaft washer	N/C
P-112-S0	" " solenoid mounting bracket50
P-113-S0	" " ratchet pawl operating lever50
P-115-S0	" " ratchet pawl arm roller bracket50
P-116-S0	" " pawl lever return stop bracket50
P-117-S0	" " pawl lever return spring bracket25
P-118-S0	" " brush mounting frame base	1.00
P-119-S0	" " collector ring spacing washer	N/C
P-120-S0	" " connector and spacer	N/C
P-121-S0	" " ratchet	1.50
P-122-S0	" " collector ring end clamping washer	N/C
P-123-S0	" " cover	1.50
P-124-S0	" " drum left end web and hub	2.50
P-125-S0	" " " right " " " "75
P-126-S0	" " commutator	3.00
P-127-S0	" " lamp mounting bar75
P-128-S0	" " reel strip	1.00
P-129-S0	" " operating coil	1.50
P-130-S0	" " right side frame plate	1.00
P-131-S0	" " left " " " "	1.00
P-137-S0	" " brush holder mounting plate	1.00
P-138-S0	board lights switch contact plate-upper	1.50
P-139-S0	" " " " " " -lower	1.50

ODDS CHANGER (con't.)

Screw Machine:

M-101-S0	Odds changer	collector ring clamping thrust collar	.25 \$.25
M-102-S0	"	" " " " nut	.25 .25
M-103-S0	"	solenoid connecting rod pin	.25 .25
M-104-S0	"	ratchet pawl arm bearing stud	.25 .25
M-105-S0	"	left hand thrust collar	.25 .25
M-106-S0	"	drum to commutator spacer	.25 .25
M-107-S0	"	brush holder pillar	.25 .25
M-108-S0	"	ratchet pawl roller shaft	.25 .25
M-109-S0	"	pawl operating lever hub	.25 .25
M-110-S0	"	frame upper pillar	.25 .25
M-111-S0	"	frame lower pillar	.25 .25
M-112-S0	"	drum core	.50 .50
M-113-S0	"	ratchet hub	.25 .25
M-114-S0	"	drum shaft	.25 .25
M-115-S0	"	ratchet pawl roller	.25 .25
M-117-S0	"	brush frame locating sleeve	.25 .25

Springs, Switches:

S-1-S	Odds Changer	double commutator brush 1-3-4-5	.10 .10
S-3-S	"	commutator brush 2-6-7A-7B	.10 .10
S-16-S	"	collector ring brushes	.25 .25
S-17-S	"	ratchet pawl operating lever spring	.10 .10
S-18-S	"	" " arm spring	.10 .10

COIN CHUTE (Old Style)

Castings:

C-4-S	Coin chute housing - front and back	10.00
C-5-S	Handle	1.50
C-8-S	Coin chute housing base	3.00

Punch Press:

P-203-SM	Coin chute housing window glass clamp	.50
P-206-SM	Wire Guard	.75
P-209-SM	Coin plate	1.00
P-210-SM	Coin chute celluloid	.50
P-215-SM	Clock mounting bar	.25
P-224-SM	Spinner bracket and overflow tube	.50
P-225-SM	Coin chute switch insulation paper - large	.25
P-226-SM	" " " " " " small	.25
P-228-SM	5¢ check separator body	3.00
P-229-SM	5¢ " " cover	.50
P-244-SM	Coin slot tie bar	.50
P-248-SM	Coin funnel	.50

(CITY OF NEW YORK / OFFICE OF THE COMPTROLLER)

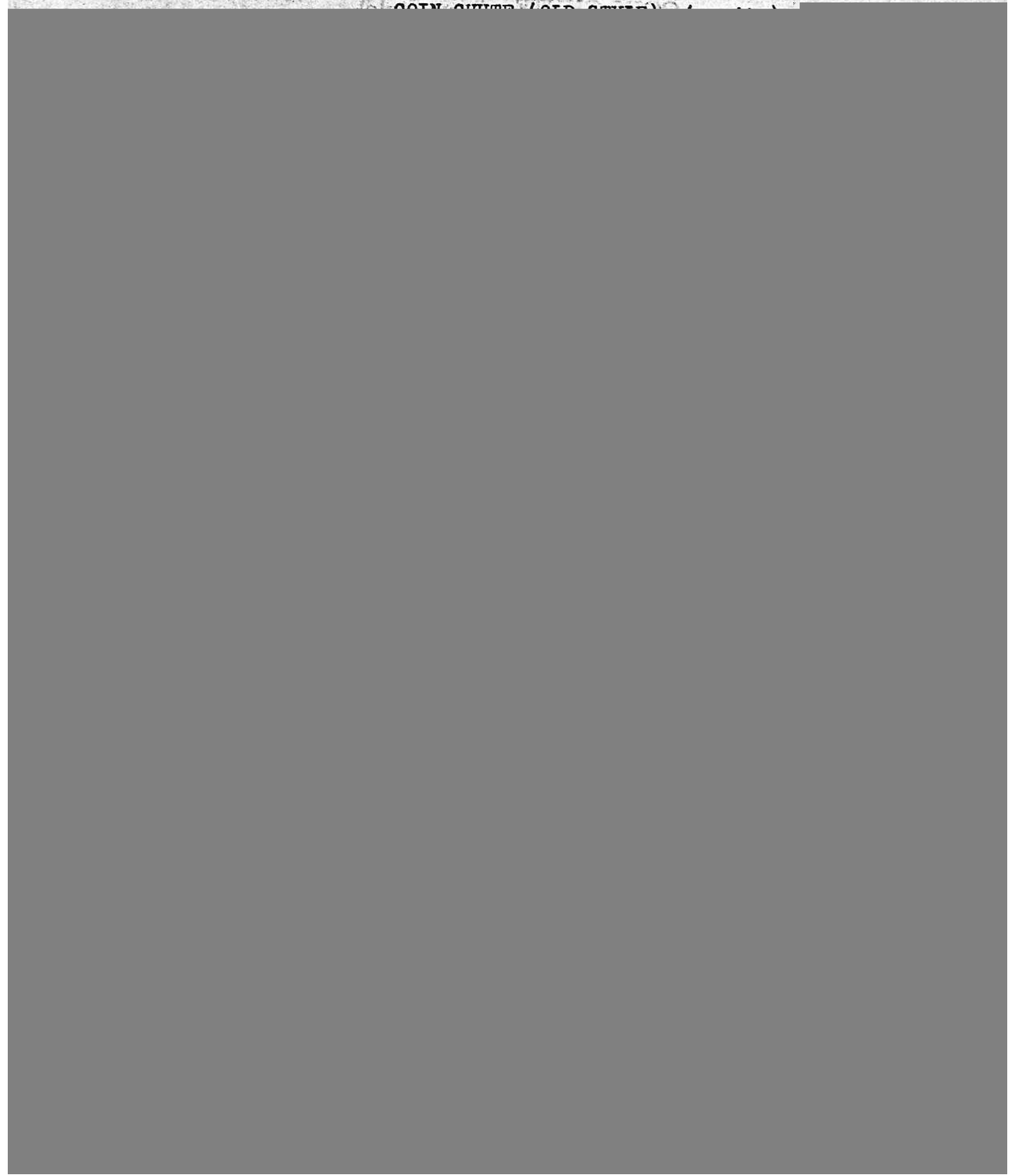

COIN CHUTE (NEW STYLE) (con't.)

Screw Machines:

M-230-SM	Ball inserting tool	\$.50
M-231-SM	Coin switch plunger	.25
M-232-SM	Handle drive screw	.25
M-233-SM	Housing anchor pin	.25
M-238-SM	Coin trip shaft	.50
M-240-SM	" " spacer	.25
M-241-SM	Main shaft	.25
M-246-SM	Brace bar	.25
M-259-SM	Shoulder screw	.25
M-260-SM	" "	.25
M-261-SM	" "	.25
M-262-SM	" "	.25
M-263-SM	Pump post	.25
M-265-SM	Booster spacer	.25

Springs, Switches:

S-20-S	Coin chute light and payout switch	
S-21-S	Separator lever spring	
S-22-S	Separator gage bar spring	
S-23-S	Handle return spring	
S-24-S	" "	
S-25-S	Pump	
S-26-S	Coin trip spring	
S-27-S	Latch spring	
S-28-S	Ratchet dog spring	
S-29-S	Switch rod spring	
S-30-S	Bell crank spring	
S-33-S	Left shaft return spring	
S-34-S	Pusher spring	
	Starting switch	

Miscellaneous Assemblies:

I-34-SM	Coin slot housing window	
I-36-SM	Coin carrier assembly	
I-38-SM	Check separator gate assembly	
I-42-SM	Coin runway assembly	
I-43-SM	Coin slide stamping assembly	

PAYOUT UNIT

Castings:

C-1-PM	Payout coin stack base, double nickel	
C-2-PM	" " " " single nickel	
C-3-PM	" " " " Franc and Shilling	

(17 nos) PAYOUT UNIT (con't.)

Punch Press:

P-200-PM	Commutator contact brush		\$ 1.00
P-201-PM	Payout base plate		1.00
P-202-PM	Payout center plate		.75
P-203-PM	" lever yoke		1.50
P-204-PM	" armature connecting rod yoke		.25
P-205-PM	" ratchet		1.50
P-206-PM	" acting ratchet pawl		.50
P-207-PM	" retaining pawl		.50
P-208-PM	" commutator base		.75
P-212-PM	" coil clamping band		.25
P-213-PM	" switch body (old style)		.50
P-216-PM	" switch stop		.25
P-223-PM	" single coin ejector		.25
P-226-PM	" register bracket		.50
P-230-PM	" ratchet shaft lubricating washer		N/C
P-231-PM	" commutator brush reinforcing top plate		.25
P-232-PM	" collector brush and switch spring insulator		N/C
P-234-PM	" commutator brush bottom insulating washer		N/C
P-235-PM	" " " top " "		N/C
P-236-PM	" " " reinforcing top plate		.50
P-237-PM	" " " clamping washer		N/C
P-238-PM	" switch contact jumper		N/C
P-261-PM	" connecting rod hinge		.25
P-290-PM	" switch bearing plate		.50
P-291-PM	" plug support		.50
P-294-PM	" oscillating switch slide		.50
P-295-PM	" " " insulator		.25
P-296-PM	" " " cam		.25

Screw Machine:

M-101-PM	Commutator shaft		.25
M-102-PM	Payout frame pillars (long)		.25
M-103-PM	" " (short)		.25
M-105-PM	" lever yoke upper spacer		.25
M-106-PM	" " shaft		.25
M-107-PM	" " lower spacer		.25
M-108-PM	" commutator brush insulating sleeve		.25
M-109-PM	" shaft lower bearing		.25
M-110-PM	" hub		.25
M-111-PM	" spacing sleeve		.25
M-113-PM	" switch spring oscillating stud		.25
M-114-PM	" disc stem		.25
M-115-PM	" armature		.25
M-116-PM	" retaining pawl spacer		.25
M-117-PM	" " " collar		.25
M-118-PM	" acting ratchet pawl bearing pin		.25
M-119-PM	" ratchet stop		.25
M-134-PM	" switch spring bushing		.25

PAYOUT UNIT (con't.)

Screw Machine:

M-135-PM	Payout switch disc bearing	\$.25
M-137-PM	Oscillating switch finger25
M-138-PM	Switch slide bearing25
M-140-PM	Oscillating switch spacer25

Springs, Switches:

S-299-PM	Connecting rod25
S-300-PM	Payout ratchet return spring10
S-301-PM	" armature return spring10
S-305-PM	" switch throwing spring10
S-306-PM	Stack base coin retaining spring10
S-307-PM	Payout retaining pawl spring10
S-308-PM	Switch to commutator contact25
S-313-PM	Payout actuating pawl spring10
S-315-PM	" switch tongue spring washer	N/C

GENERAL MISCELLANEOUS PARTS

Punch Press:

P-202-SM	Top lock nut50
P-204-SM	Payout register bracket50
P-205-SM	Window lock plate50
P-207-SM	Payout coin deflector50
P-217-SM	Top reflector (assembly)	7.50
P-218-SM	Reflector light shutter25
P-223-SM	Board lights switch contact bracket25
P-231-SM	Play board contacts25
P-232-SM	Coin chute starter switch brack25
P-233-SM	Top brace complete	1.00
P-236-SM	" " washer	N/C
P-237-SM	Cash box	2.00
P-243-SM	Board lights switch contact bracket support50
P-246-SM	Guard for spinner circle25
P-258-SM	Spinner wire clamp10
P-345-SM	Payout relay bracket50

Screw Machine:

M-200-SM	Payout resetting lever operating armature25
M-201-SM	Top locking thumb screws50
M-203-SM	Reflector lamp mounting detachable bracket75
M-205-SM	Horse ornament boss spacer25

Springs:

S-31-S	Top brace spring10
--------	----------------------------	-----

3.50

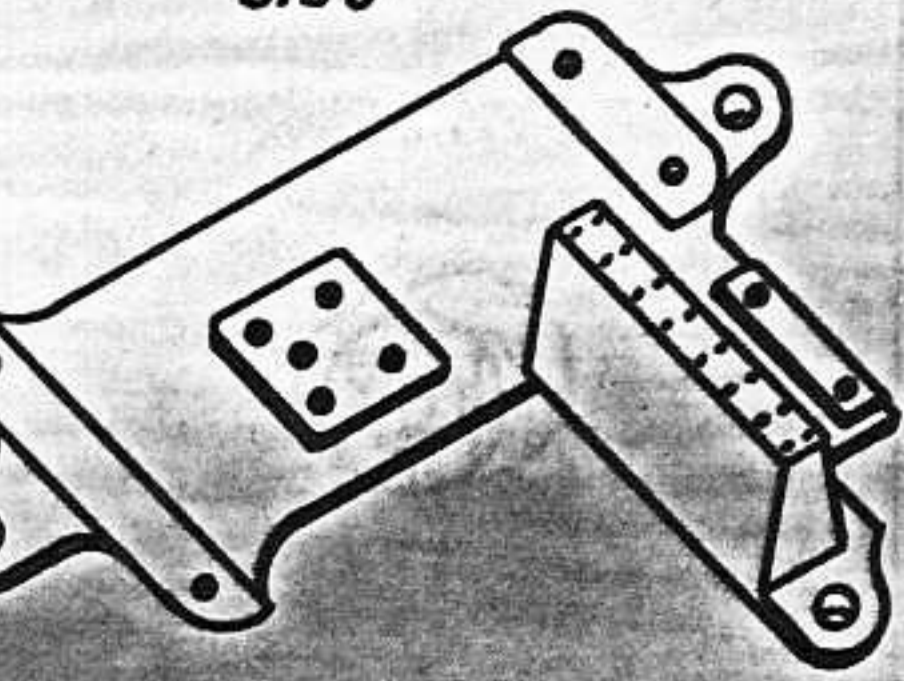

C-1-S

3.50

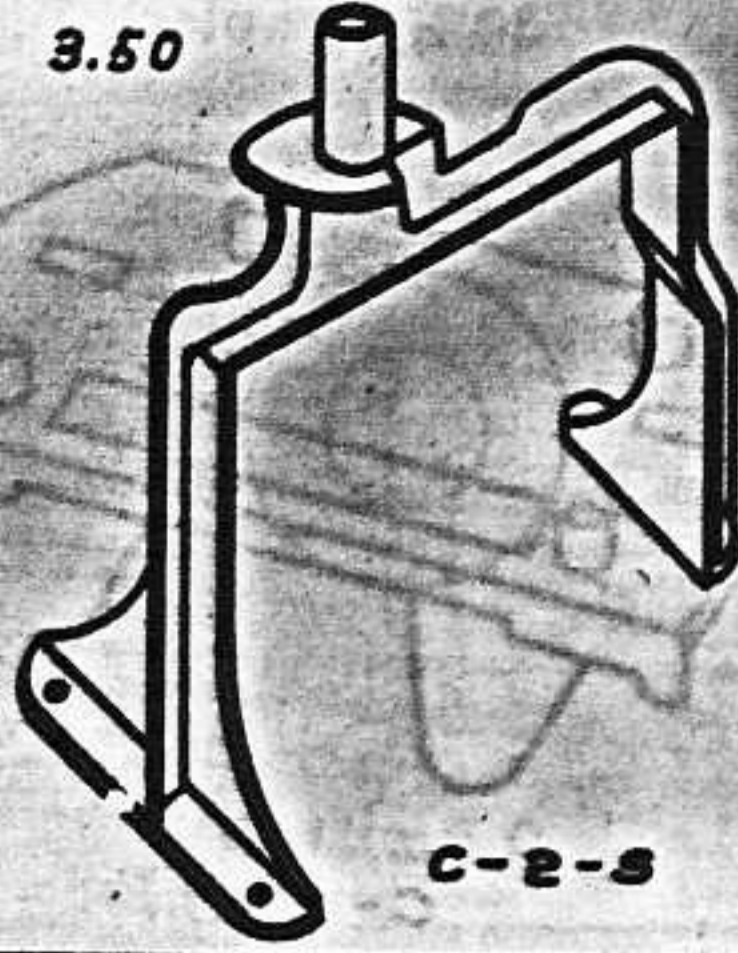

C-2-S

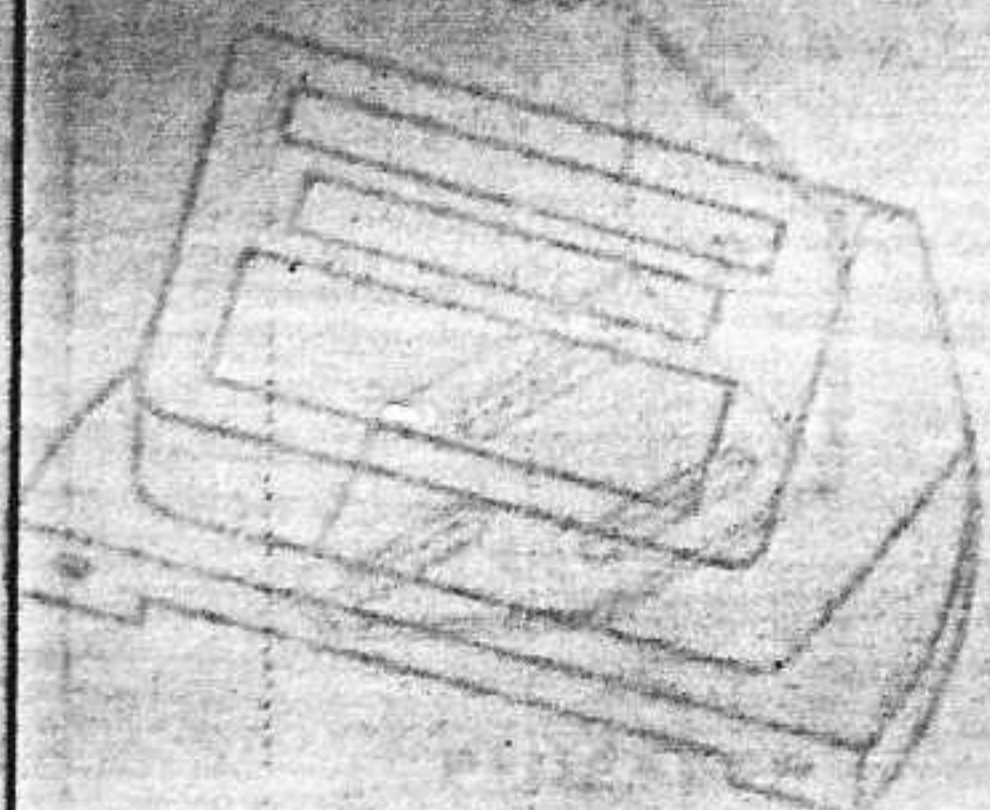

10.00

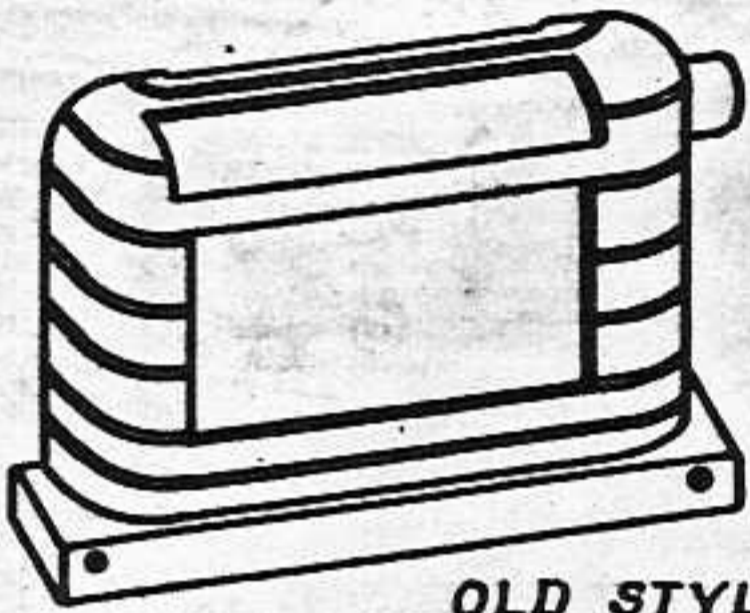

OLD STYLE

C-4-S

1.50



C-5-S

2.00

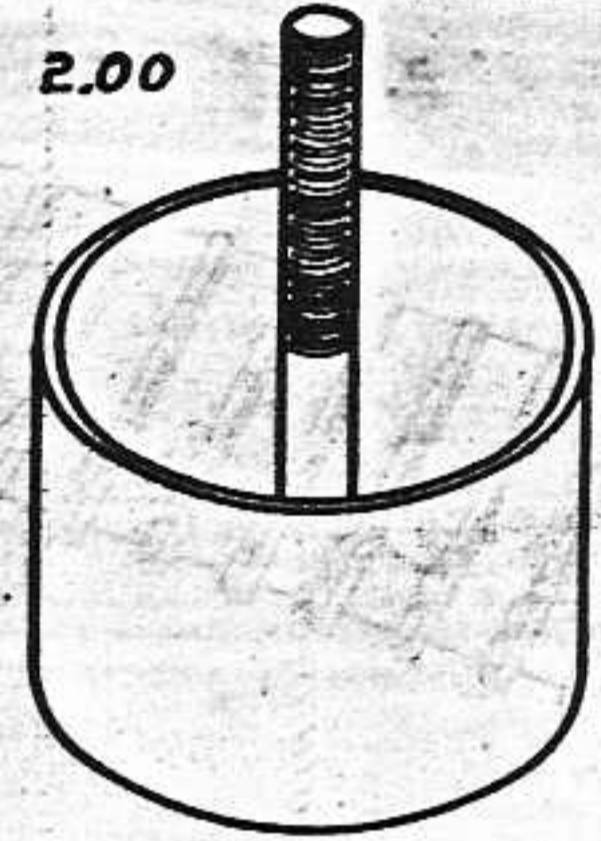

C-6-S

1.00

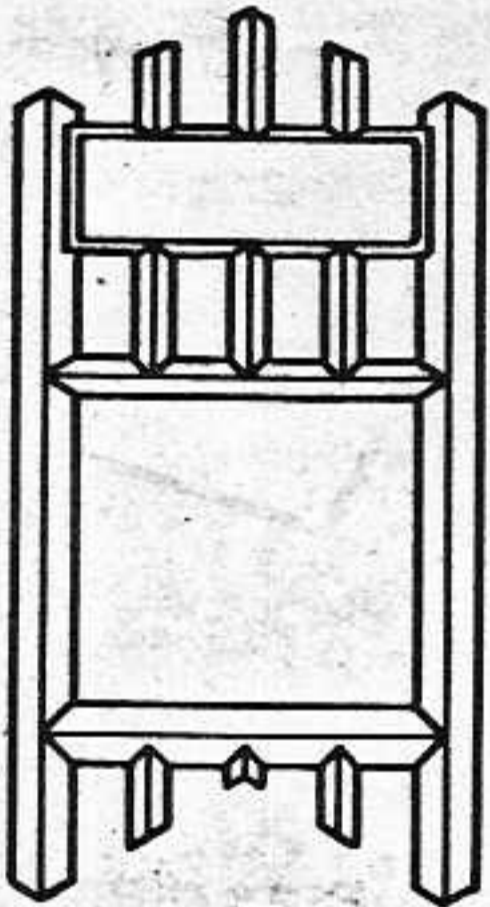

C-7-S

3.00

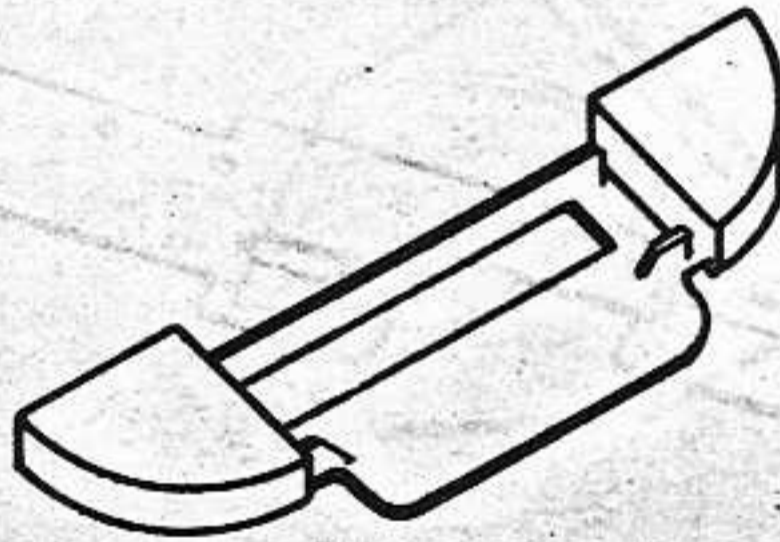

OLD STYLE

C-8-S

3.50

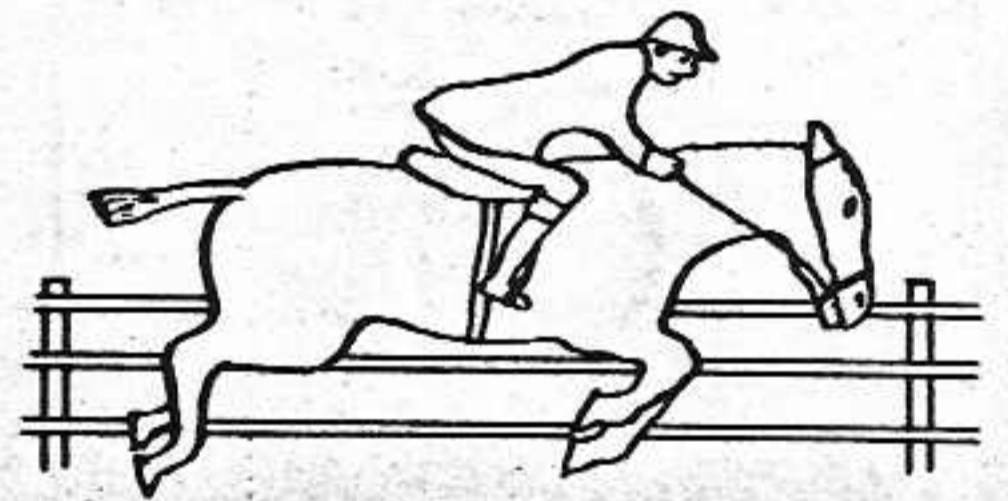

C-9-S

2.50



C-10-S

2.00

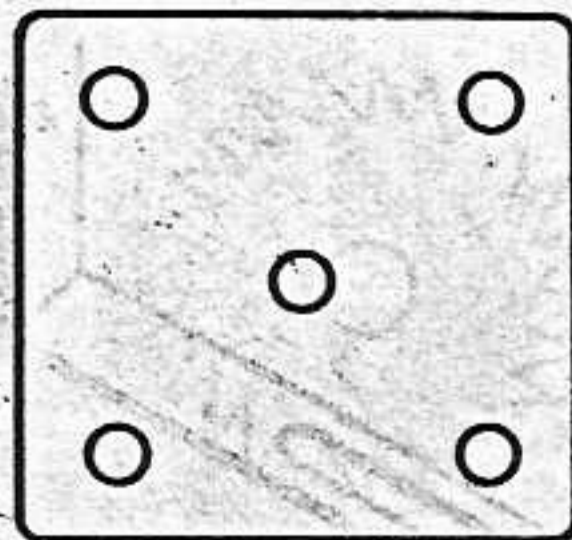

C-11-S 2 SPOT
C-12-S 5 SPOT

6.00

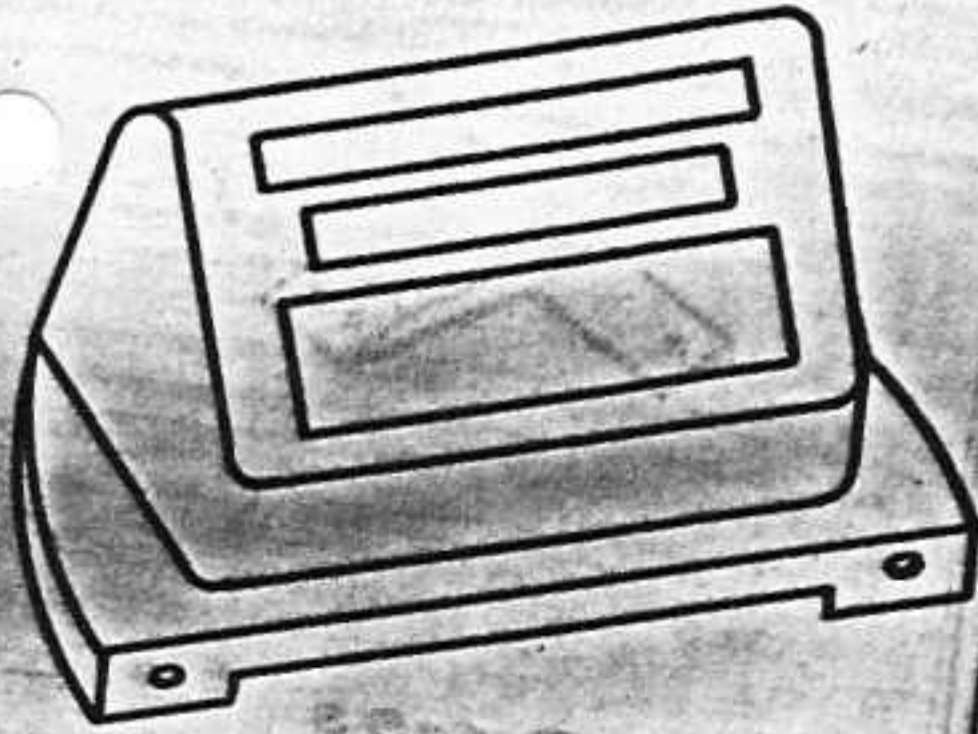

C-13-S

4.00

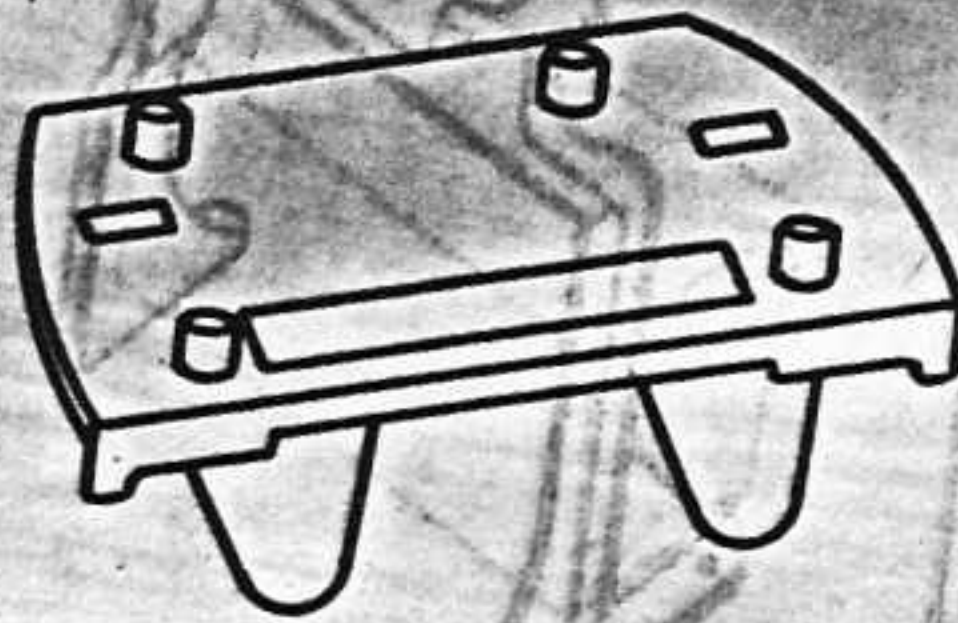

C-15-S

1.00

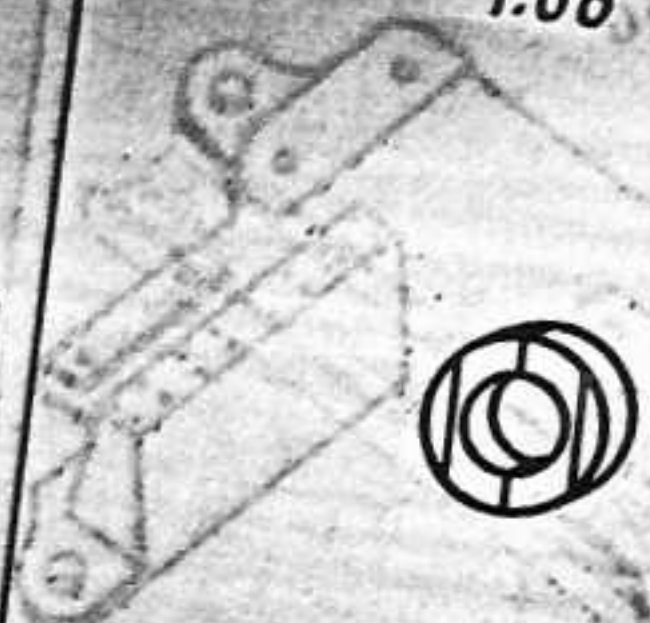

C-16-S

2.00

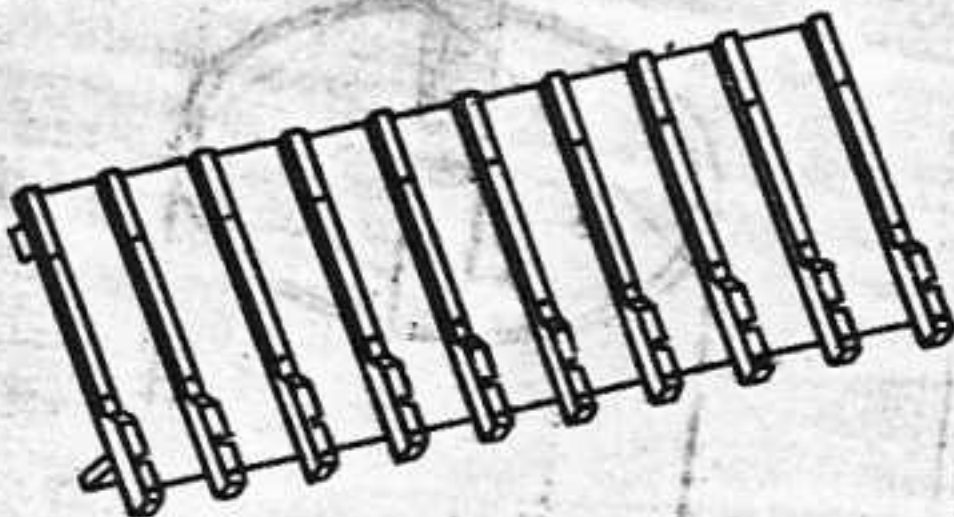

C-17-S

2.00

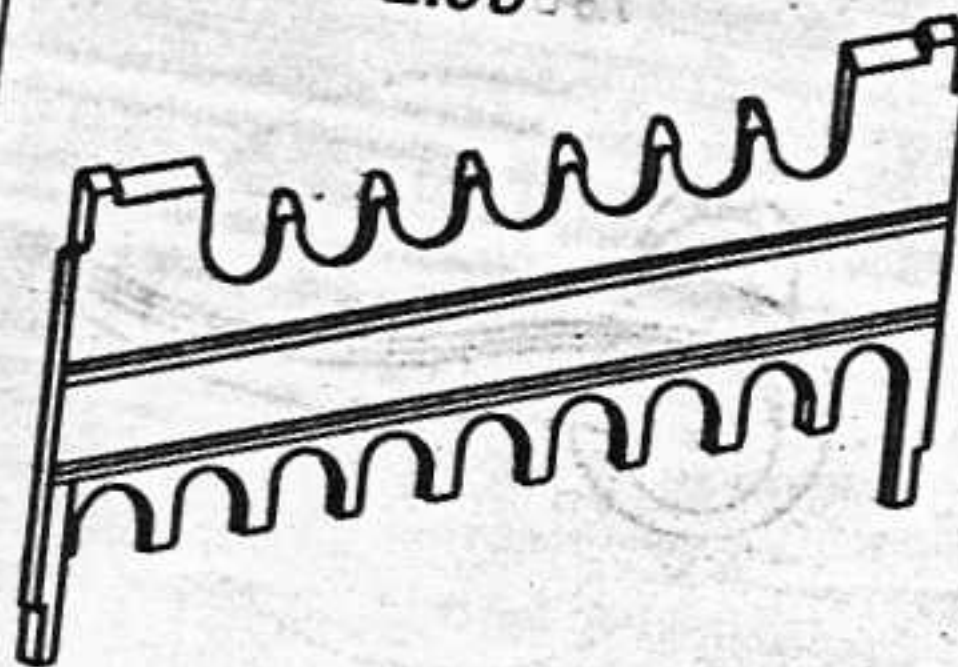

C-18-S

2.00

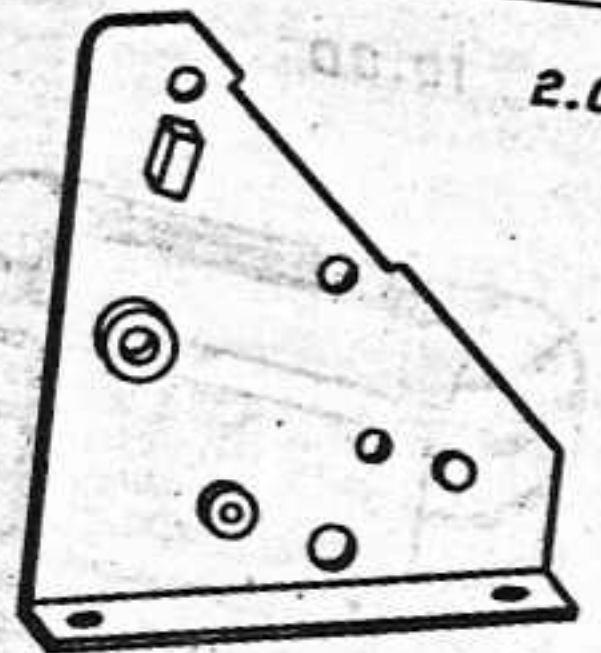

C-19-S HANDLE SIDE.
C-20-S OPP. " " SHOWN

.50

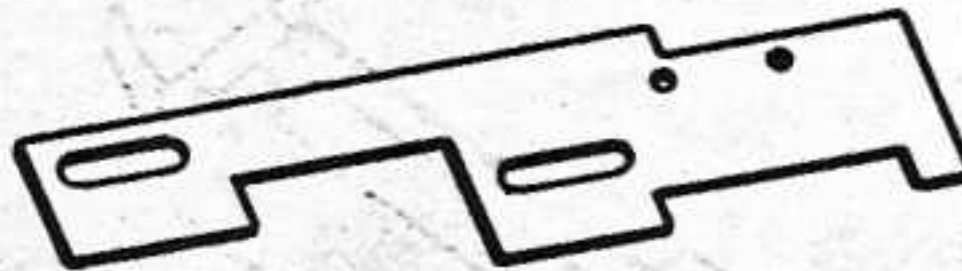

P-294-PM

.25



P-295-PM

.25

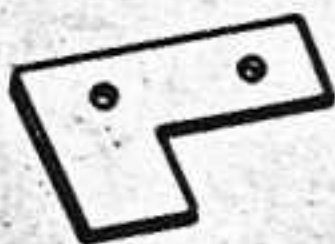

P-296-PM

.50

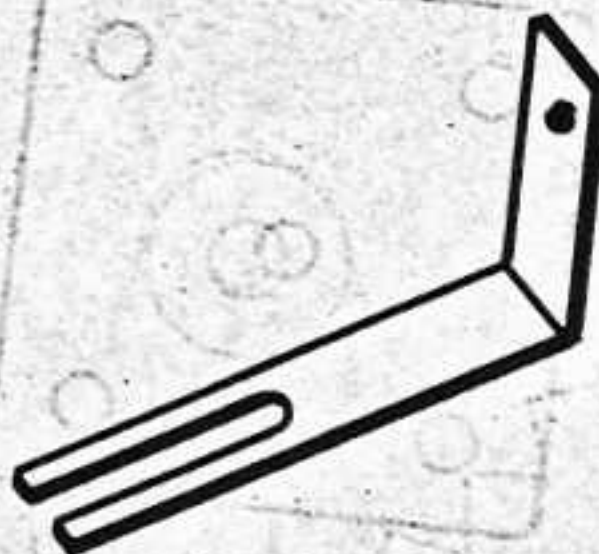

P-38-SS

1.00

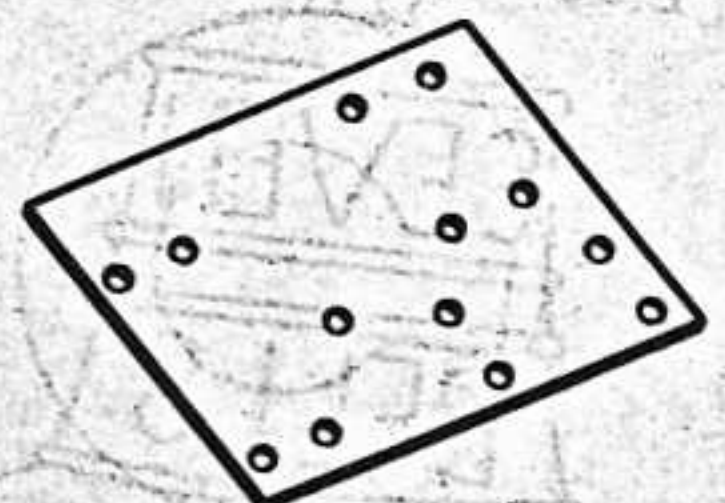

P-39-SS

1.00

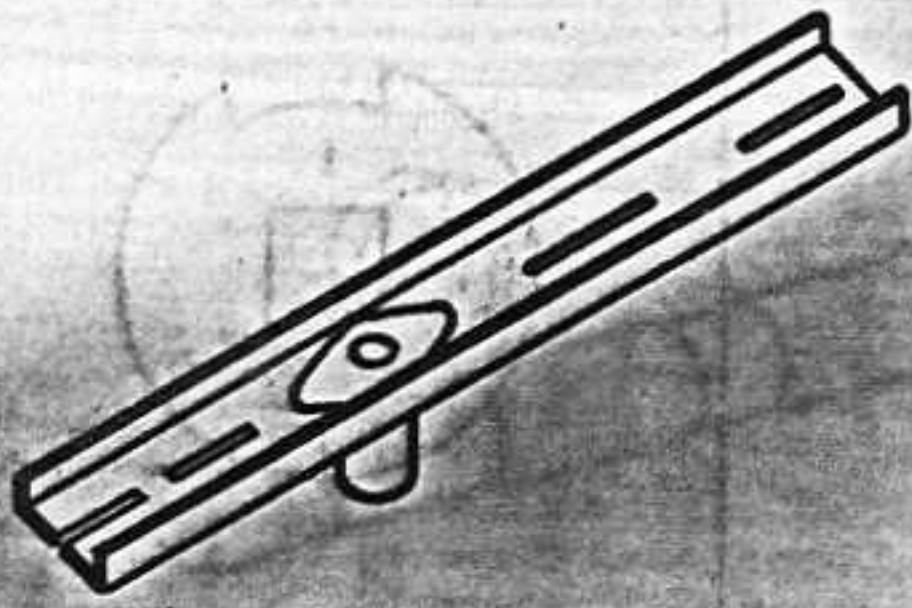

P-1-SS

.50

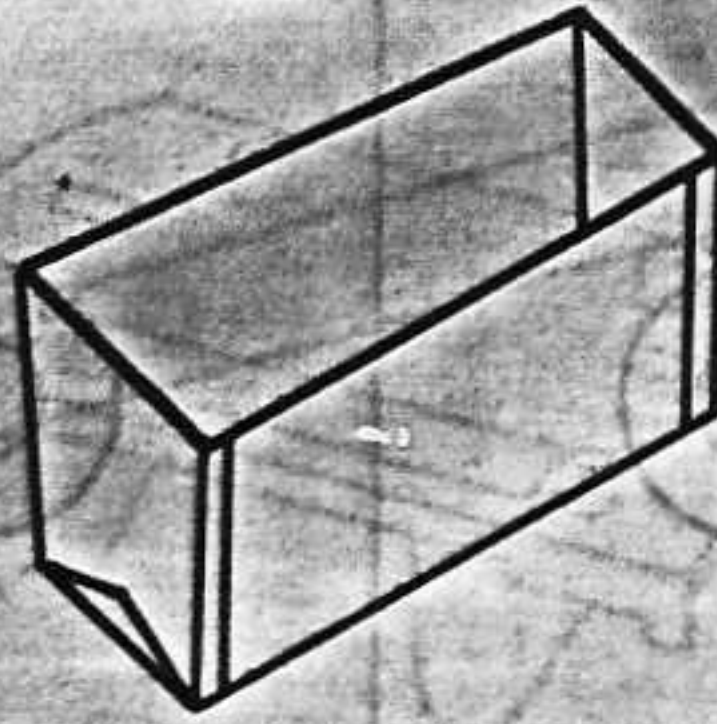

P-2-SS

.50

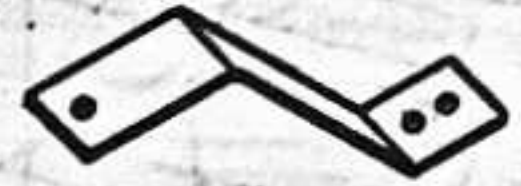

P-6-SS

NO CHARGE



P-7-SS

.50

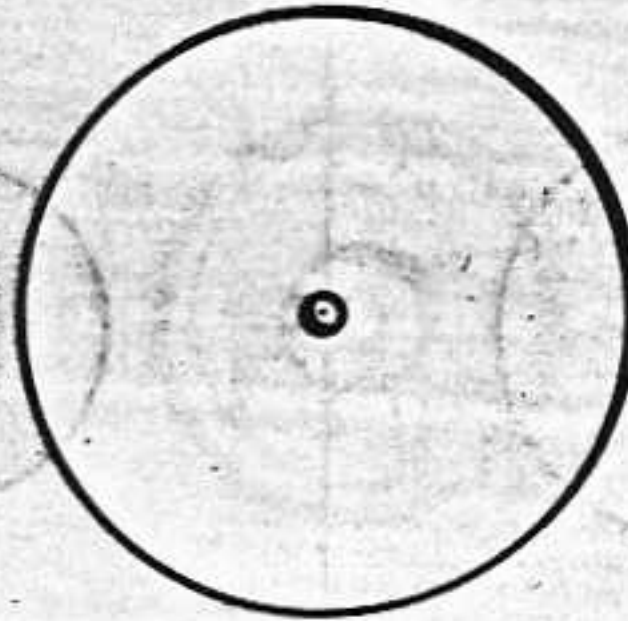

P-8-SS

.50

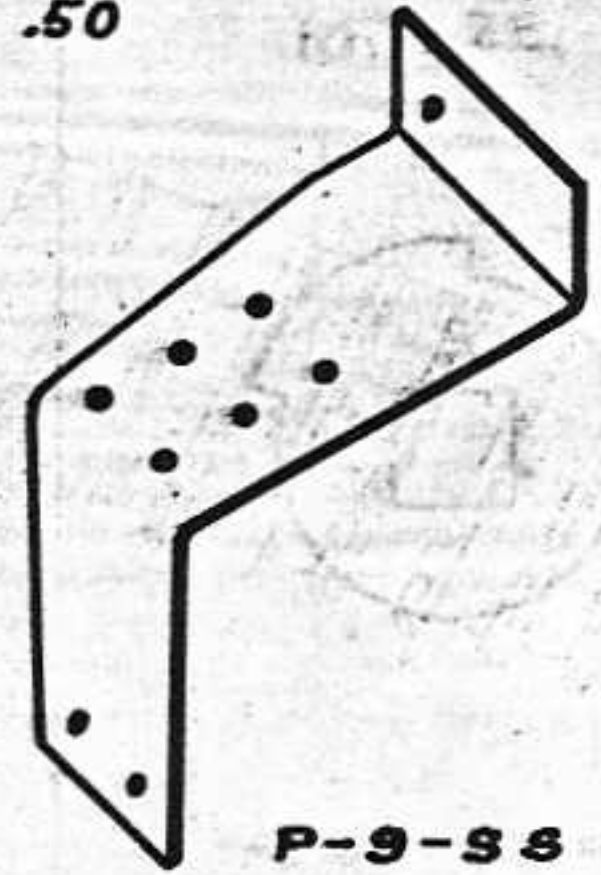

P-9-SS

.50

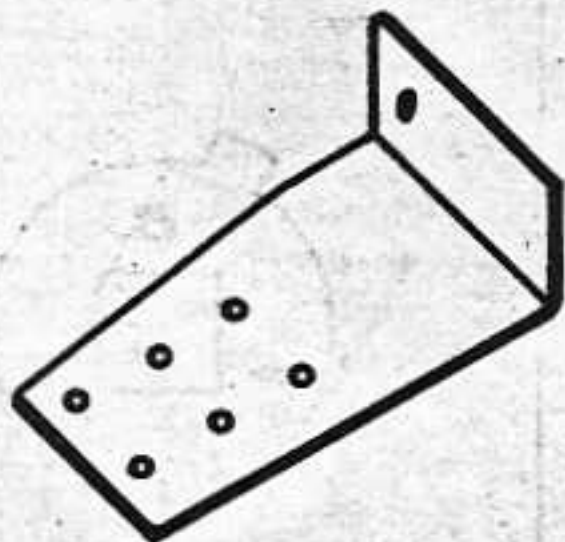

P-10-SS

.50



P-11-SS

.25



P-12-SS

.25



P-13-SS

1.50

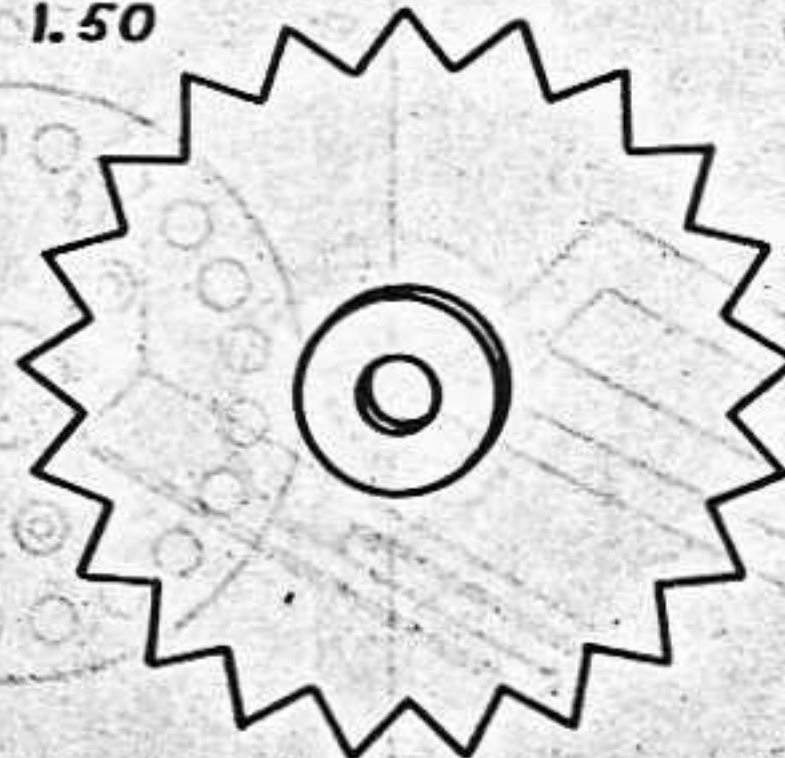

P-14-SS

2.00

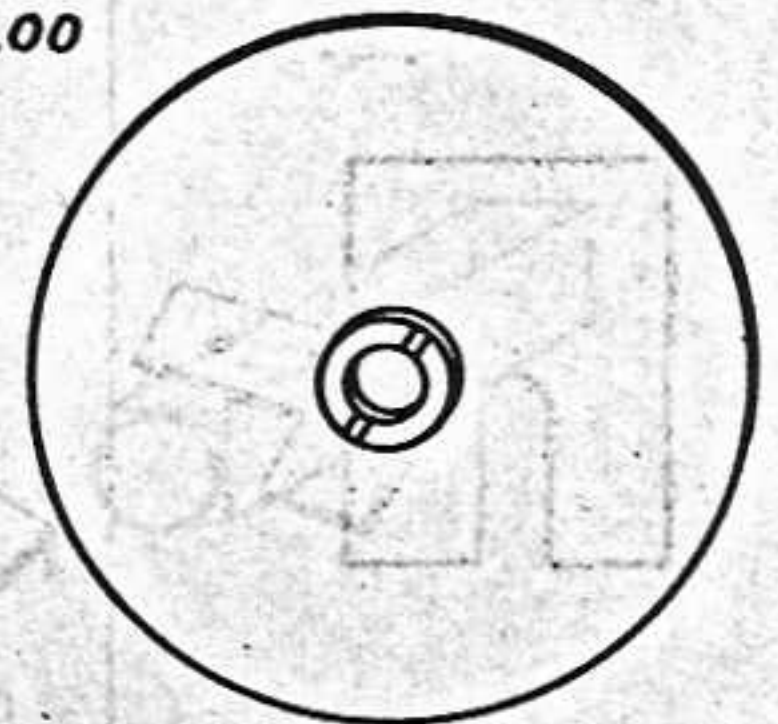

C-14-S

.50

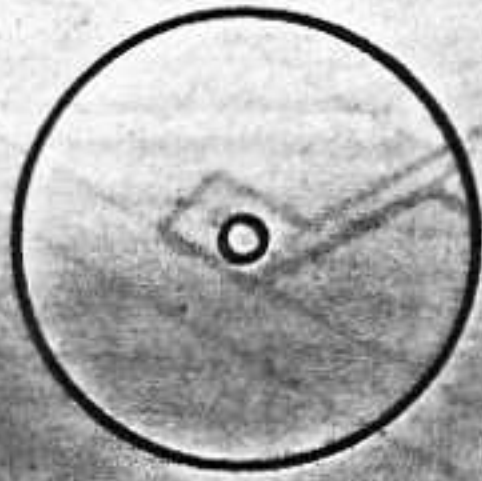

P-16-SS

NO CHARGE



P-18-SS

NO CHARGE



P-19-SS

.35



P-22-SS

.35

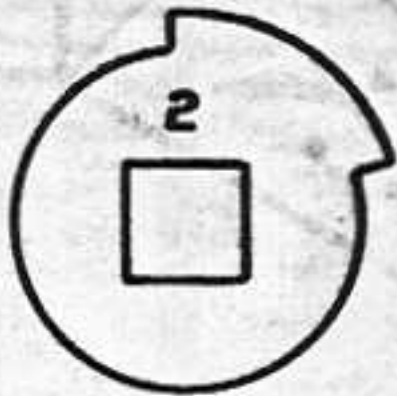

P-23-SS

.35

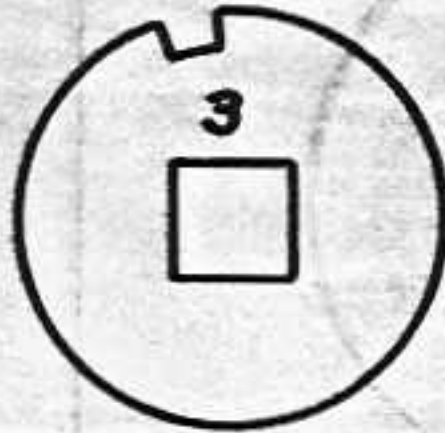

P-24-SS

.35

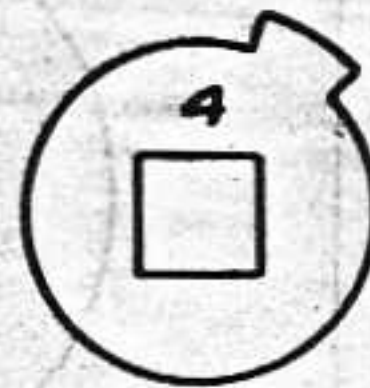

P-25-SS

.35



P-26-SS

.35



P-27-SS

.35



P-28-SS

1.50



P-30-SS

.35



P-31-SS

.25



P-33-SS

.50

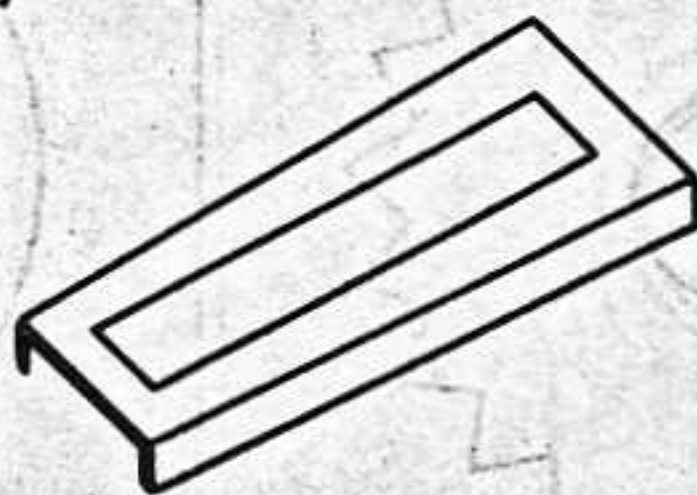

P-34-SS

3.00

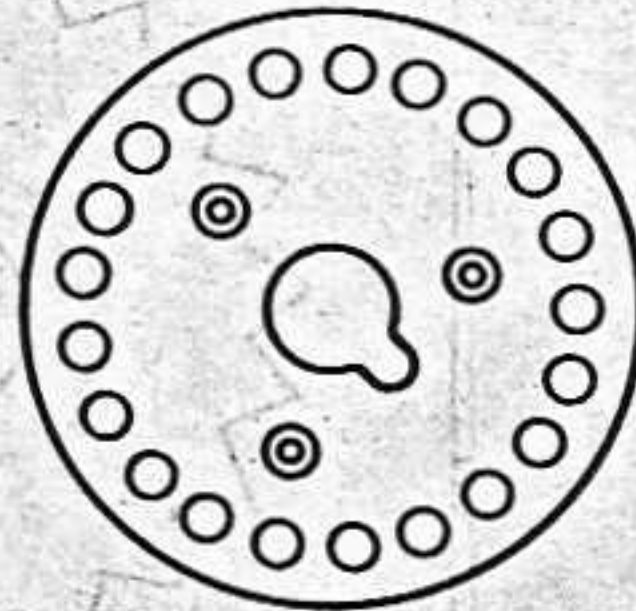

P-35-SS

.35



P-32-SS

.50

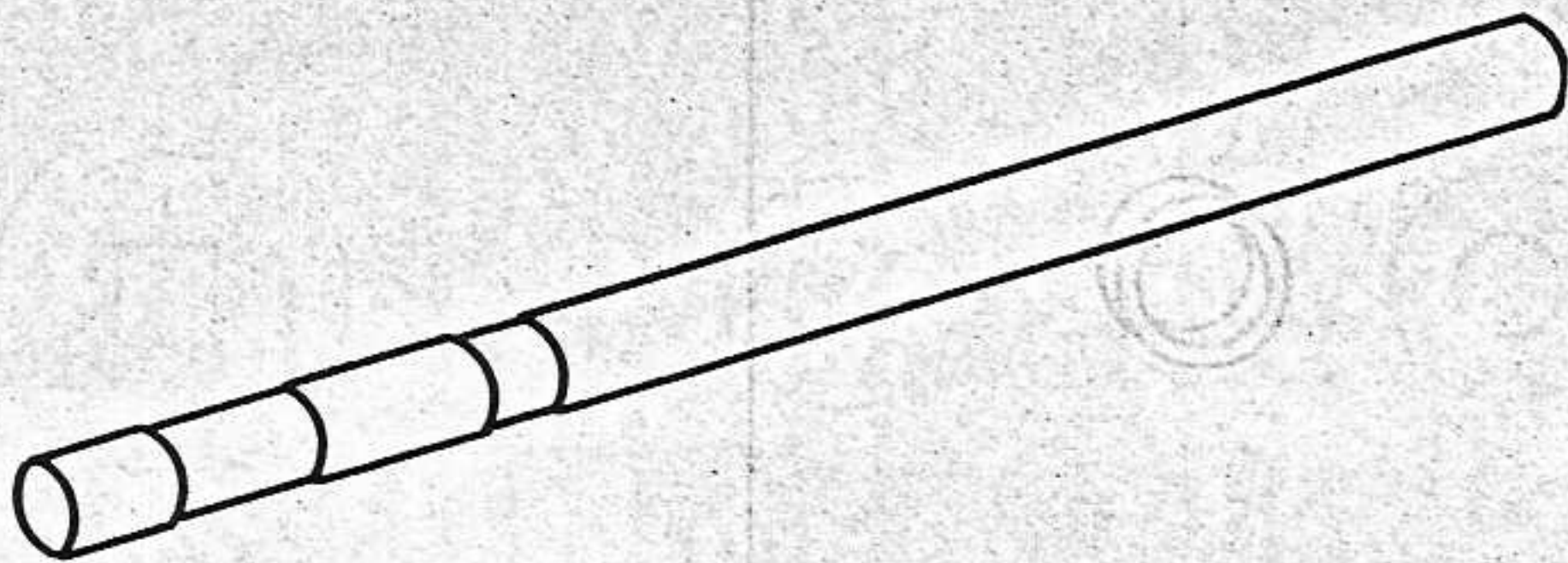

M-1-SS

.50

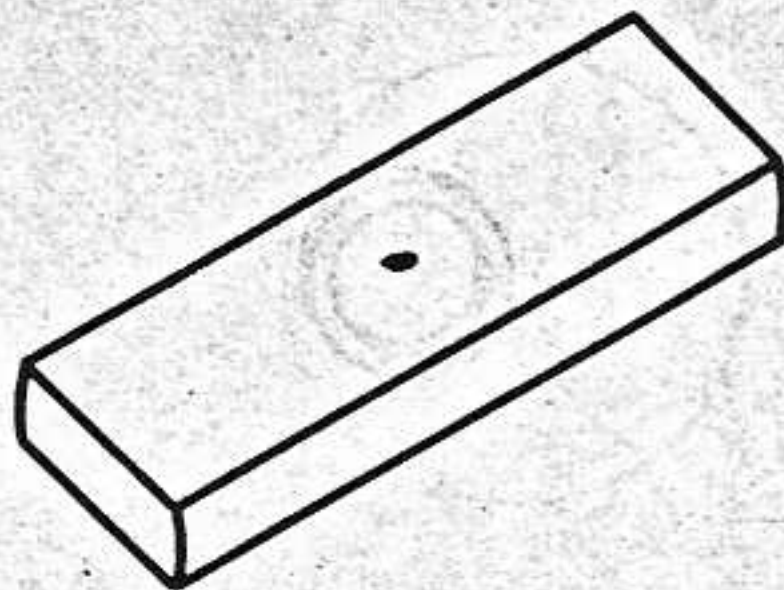

M-2-SS

.50

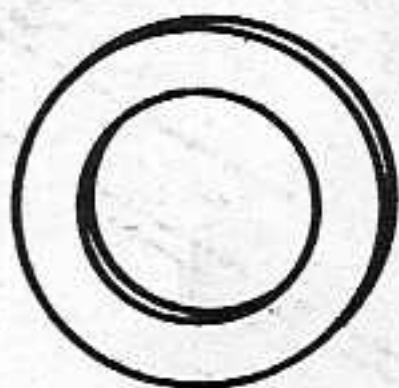

M-3-SS

.50

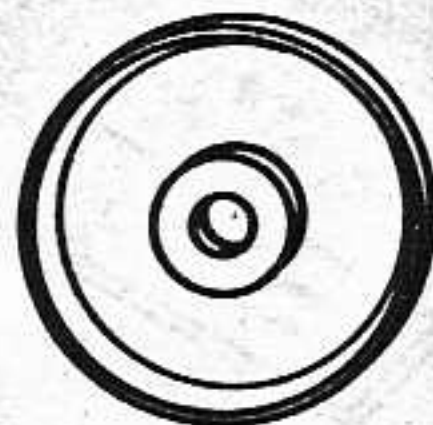

M-4-SS

.10

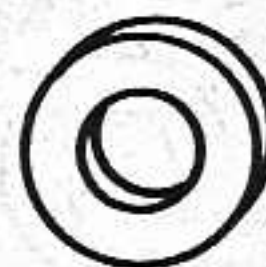

M-5-SS

.75



M-6-SS

.75

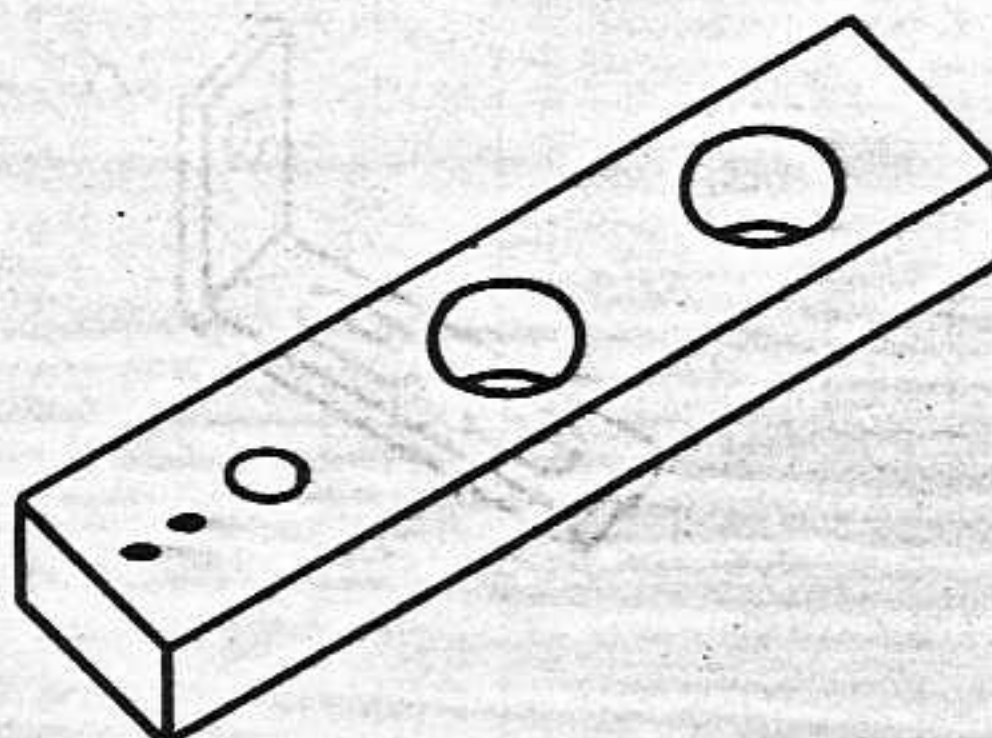

M-7-SS

.25



M-8-SS

.50



M-9-SS

.25



M-10-SS

.50

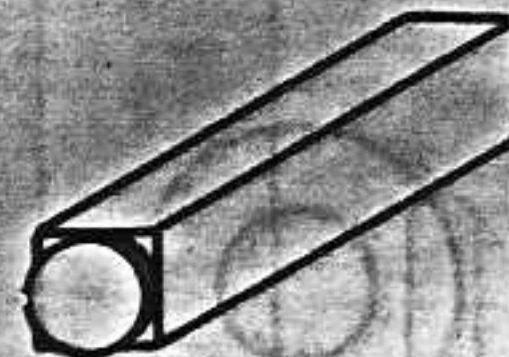

M-11-SS

.25

M-12-98

NO CHARGE

M-13-98

.50

P-101-90

.50

P-102-90

.50

P-104-90

NO CHARGE

P-105-90

NO CHARGE

P-107-90

P-106-90

.50

P-108

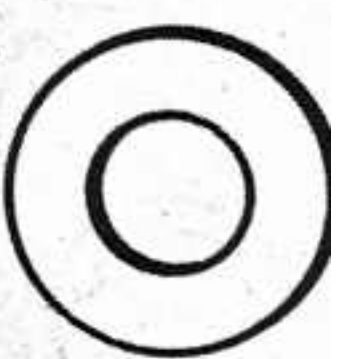
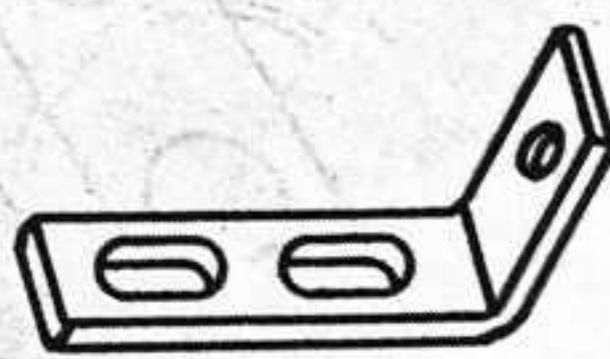
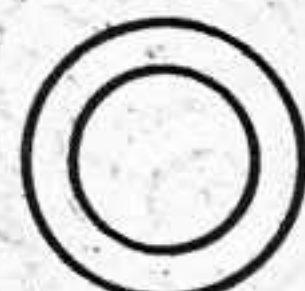

NO CHARGE

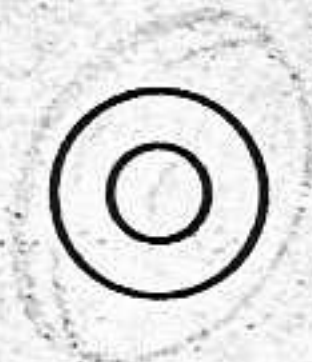

P-110-S 0

NO CHARGE

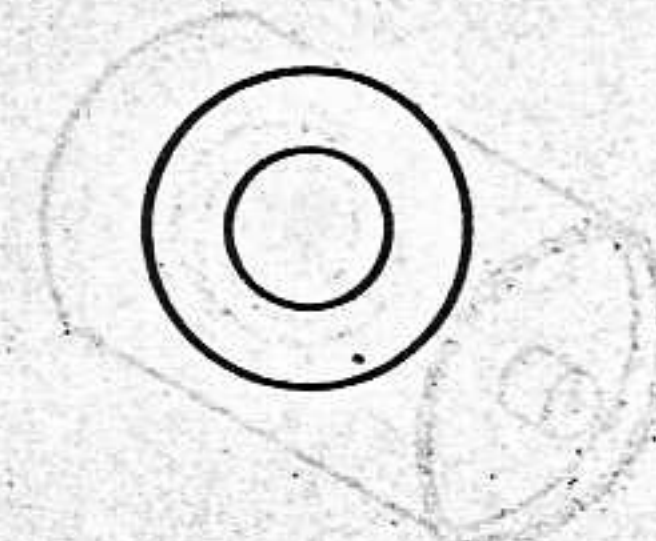

P-111-S 0

.50

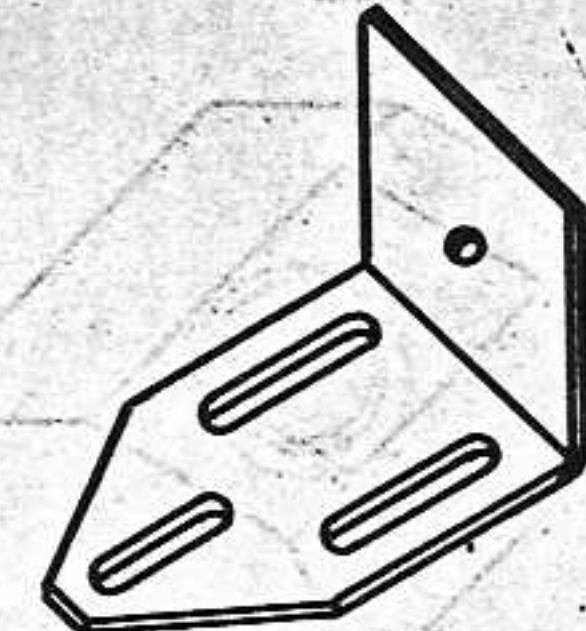

P-112-S 0

.50

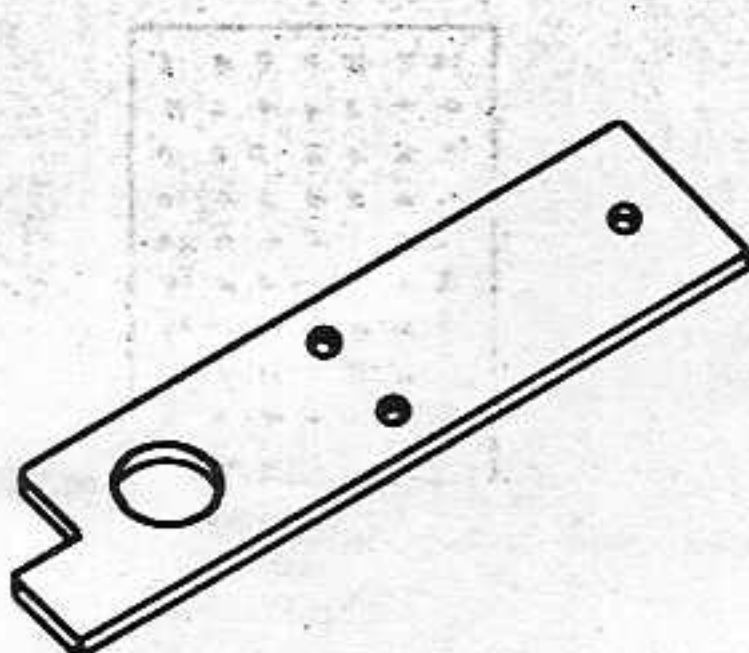

P-113-S 0

.50

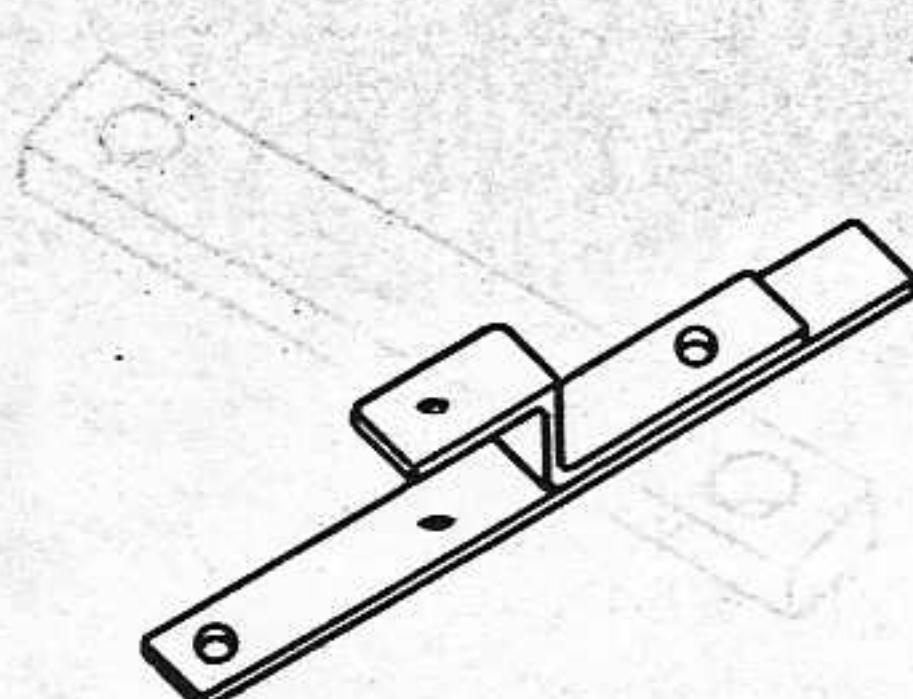

P-115-S 0

.50

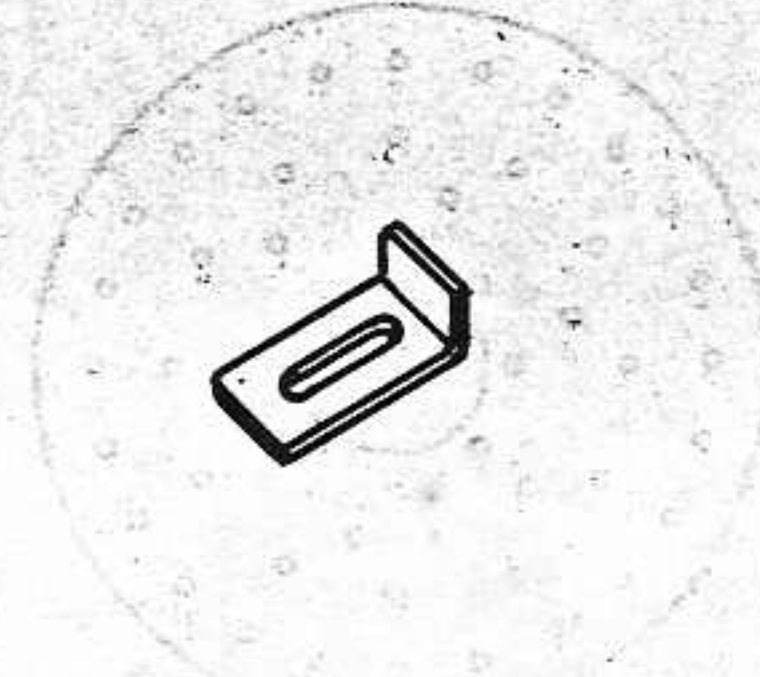

P-116-S 0

.25

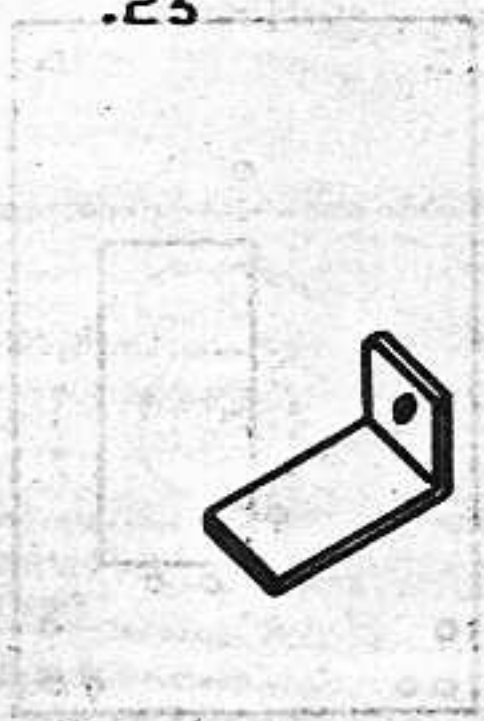

P-117-S 0

1.00



P-118-S 0

NO CHARGE

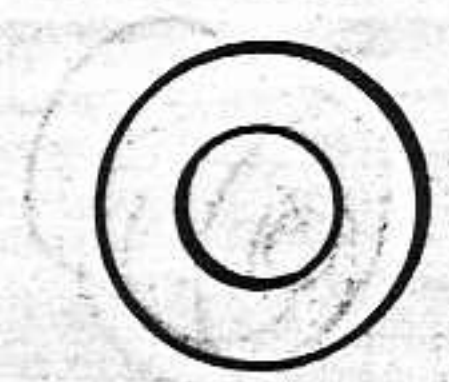

P-119-S 0

NO CHARGE

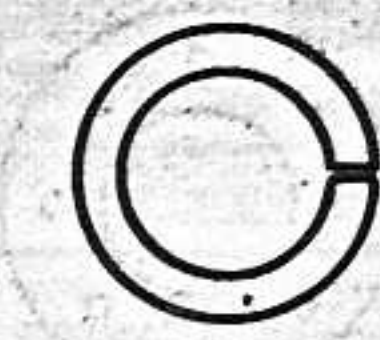

P-120-S 0

1.50

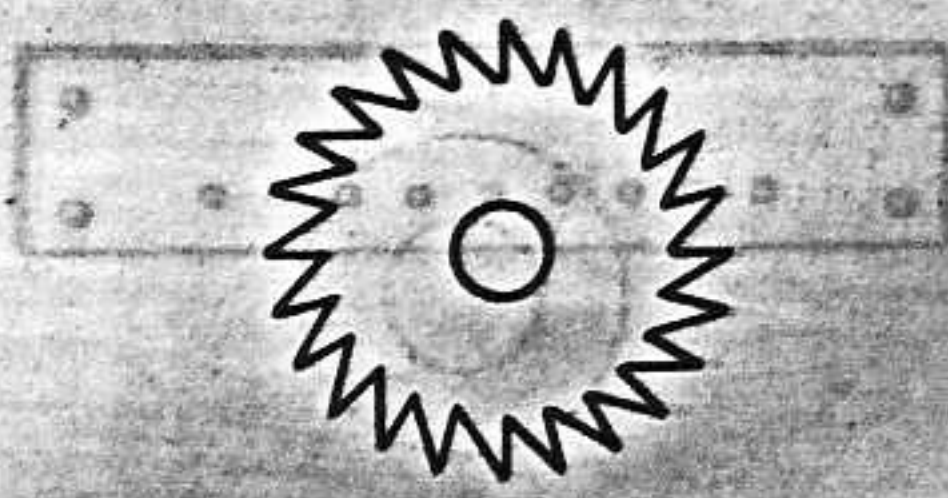

P-121-S 0

NO CHARGE

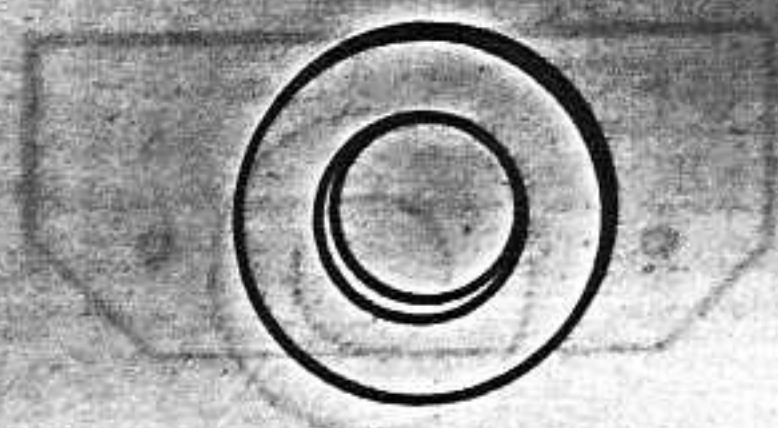

P-122-S 0

1.50

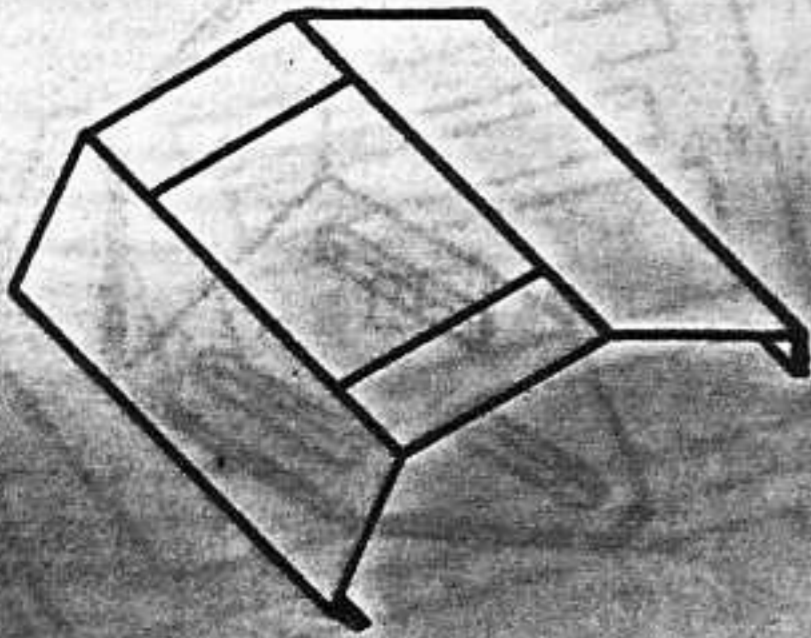

P-123-S 0

2.50

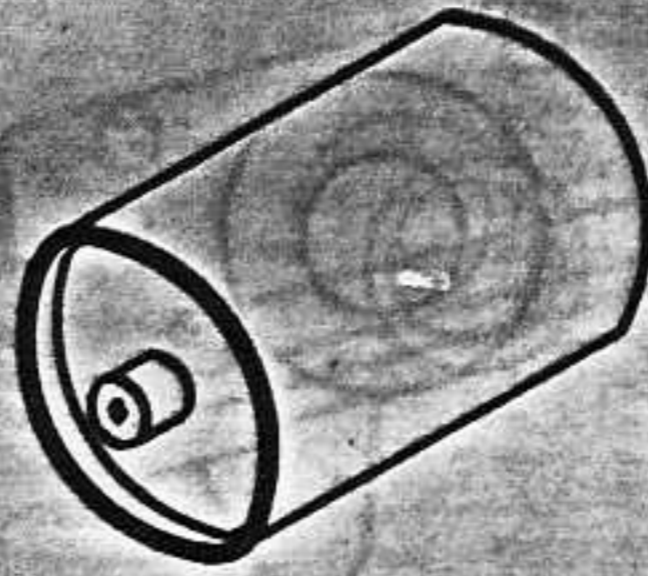

P-124-S 0

.75



P-125-S 0

3.00

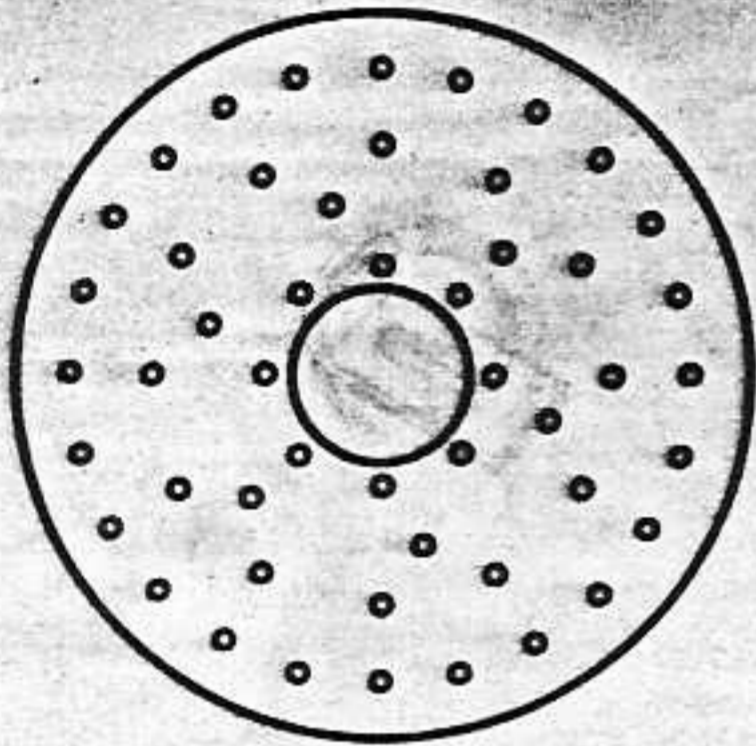

P-126-S 0

.75

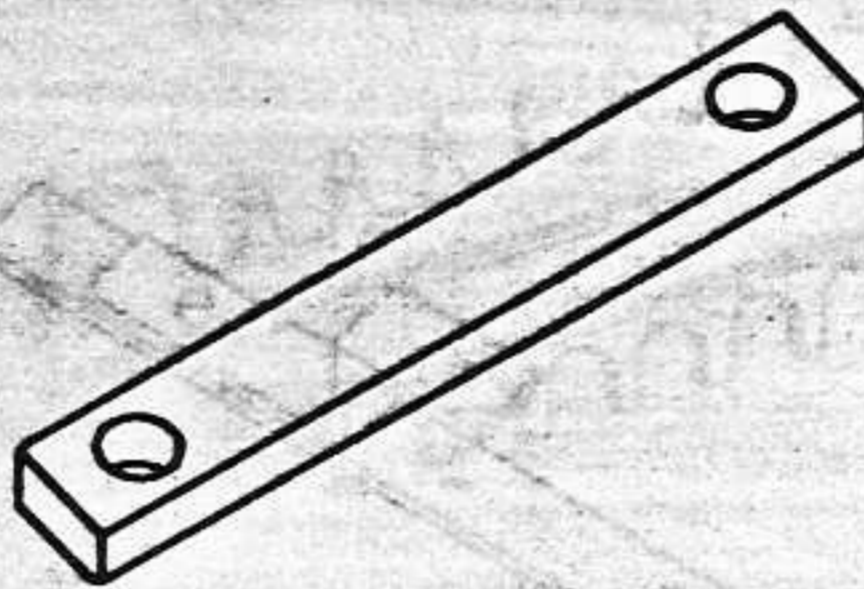

P-127-S 0

1.00

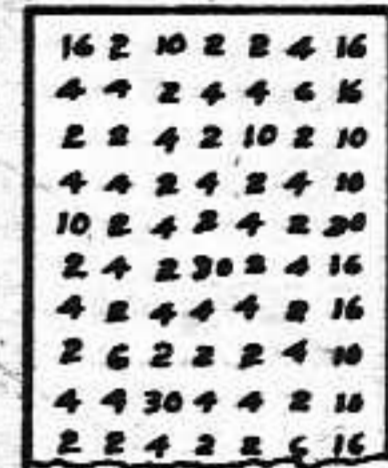

P-128-S 0

1.50

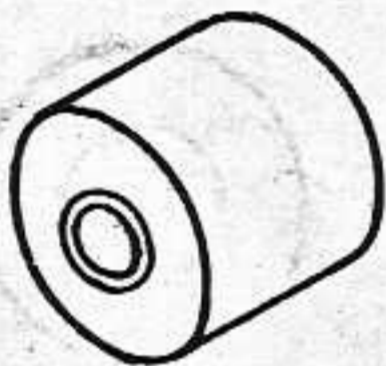

P-129-S 0

1.00

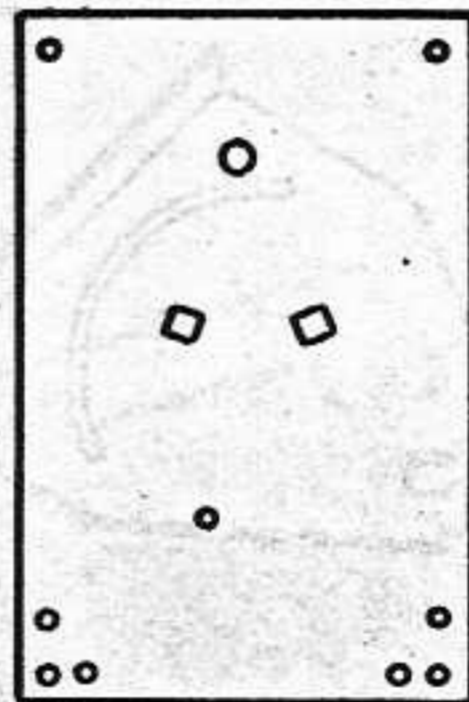

P-130-S 0

1.00

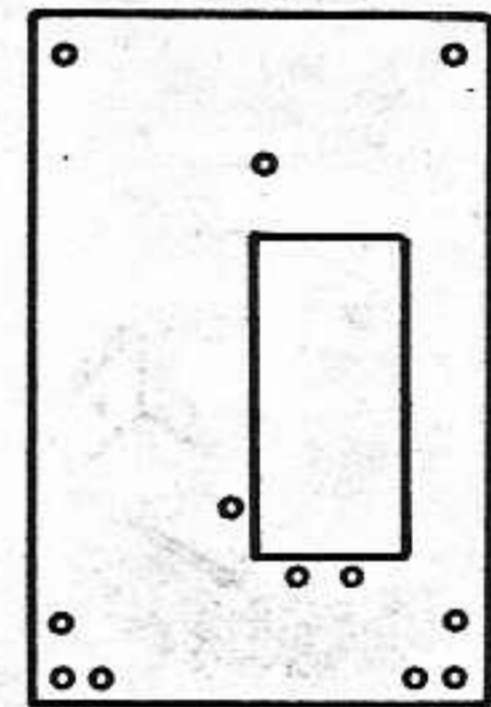

P-131-S 0

1.00



P-137-S 0

1.50

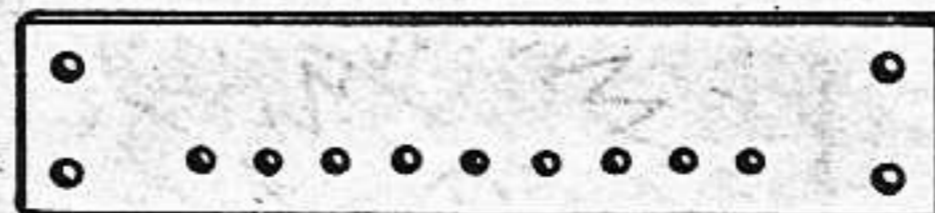

P-138-S 0 UPPER
P-139-S 0 LOWER

.25

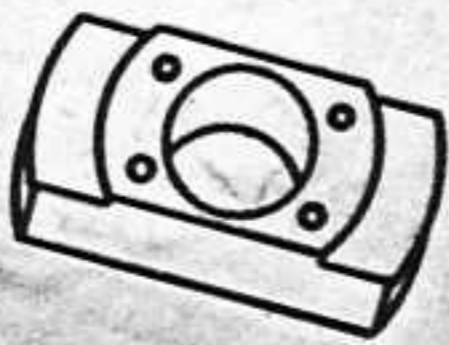

M-101-S0

.25



M-102-S0

.25



M-104-S0

.25



M-105-S0

.25

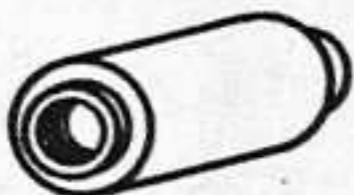

M-107-S0

.25



M-108-S0

.25



M-110-S0

.25



M-111-S0

M-109-S

.50



.25



M-113-S 0

.25



M-114-S 0

.25



M-117-S 0

.50

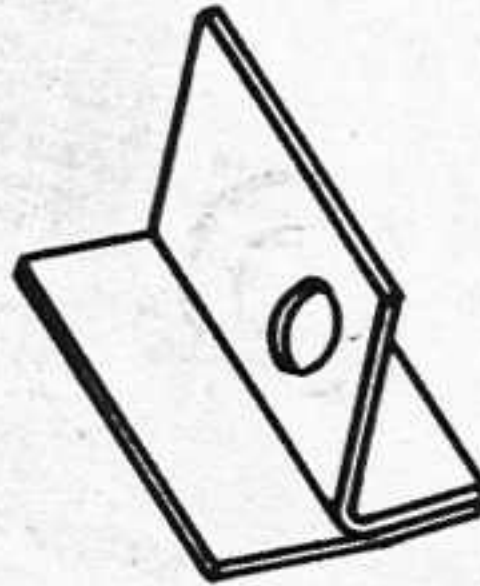

P-202-SM

.50

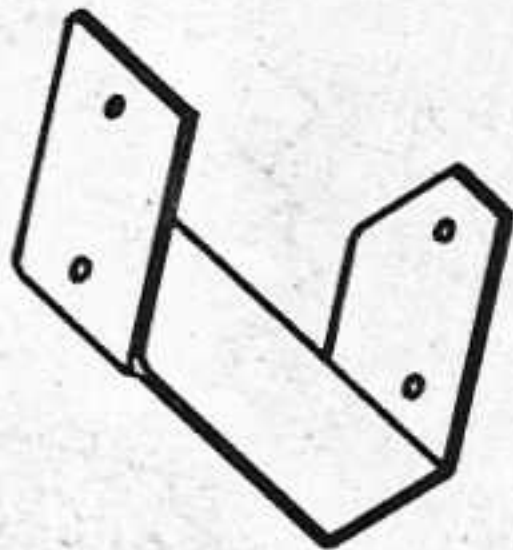

P-204-SM

.50



P-205-SM

P-203-S

.75

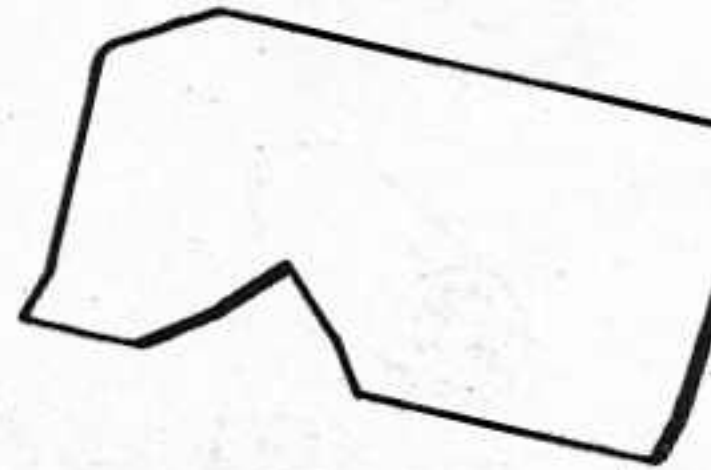

OLD STYLE

P-206-SM

.50

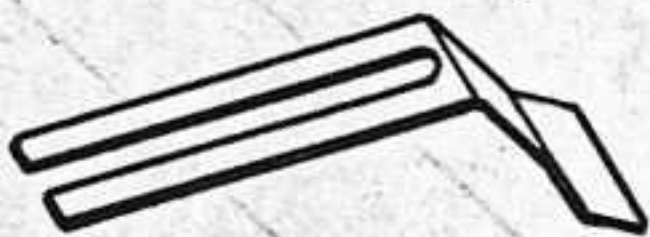

P-207-SM

.50



P-208-S

1.00

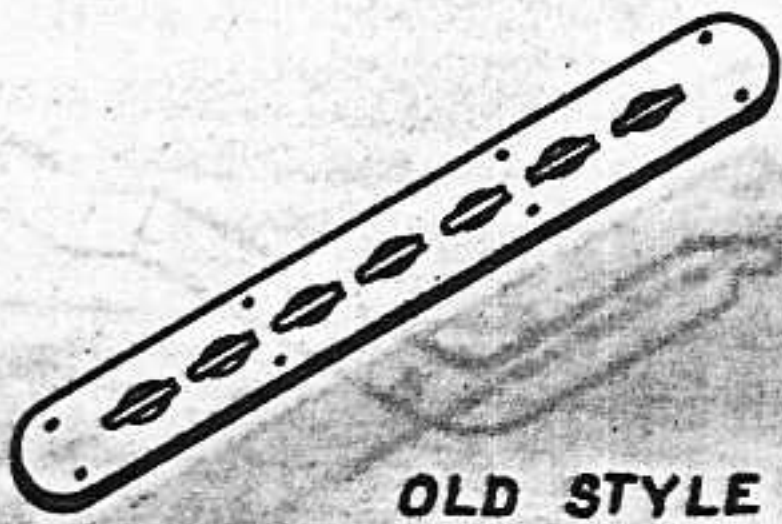

OLD STYLE

P-209-SM

.50



OLD STYLE

P-210-SM

.25

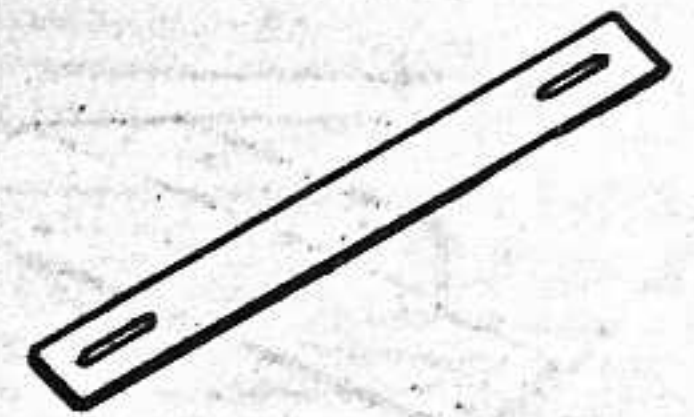

OLD STYLE

P-215-SM

7.50

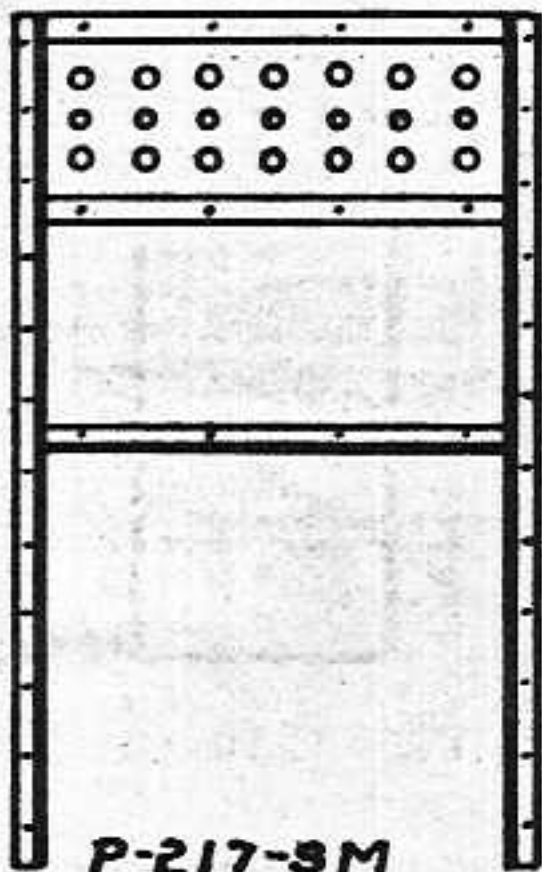

P-217-SM

.25



P-218-SM

.25

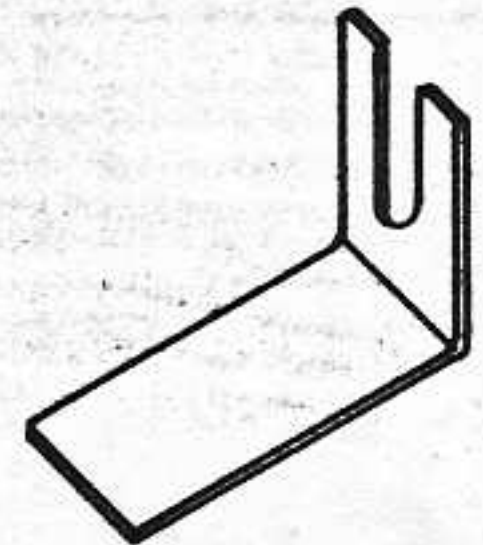

OLD STYLE

P-223-SM

.50

M-208-SM



P-224-SM

.25



P-225-SM

OLD STYLE

.25



P-226-SM

3.00

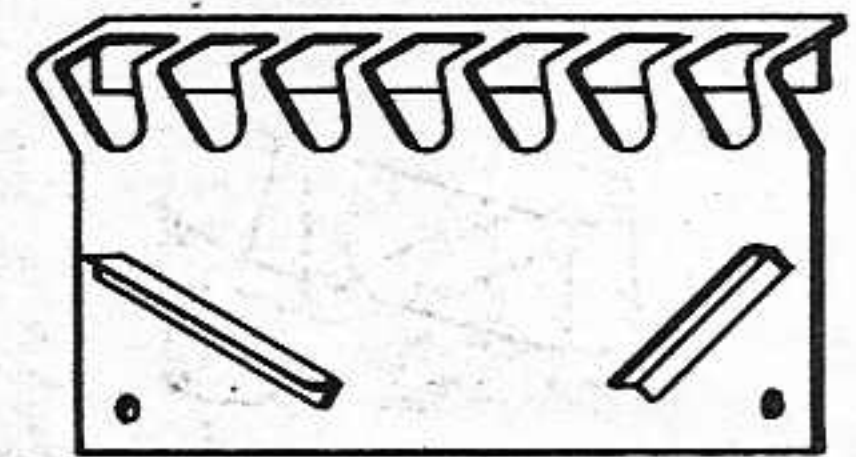

OLD STYLE

P-282-SM
P-227-SM

3.00

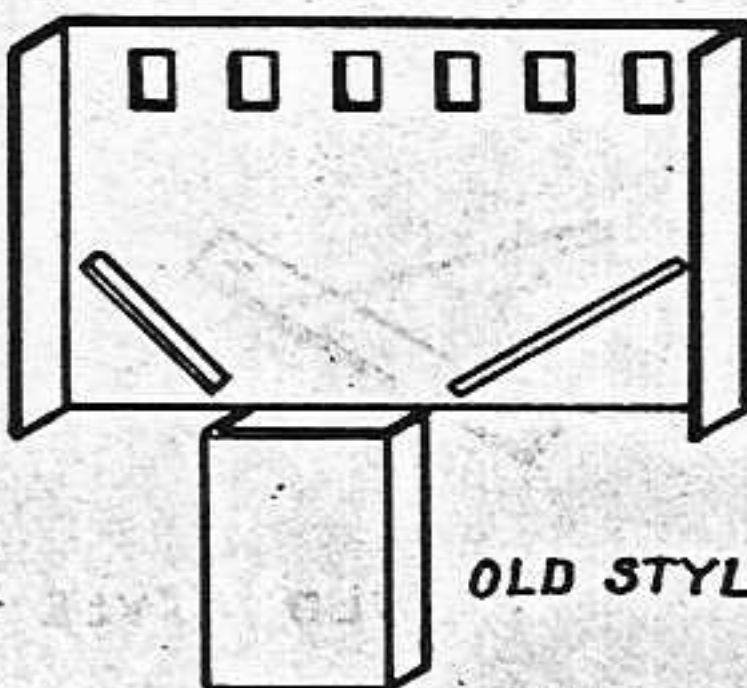

OLD STYLE

P-228-SM

.50

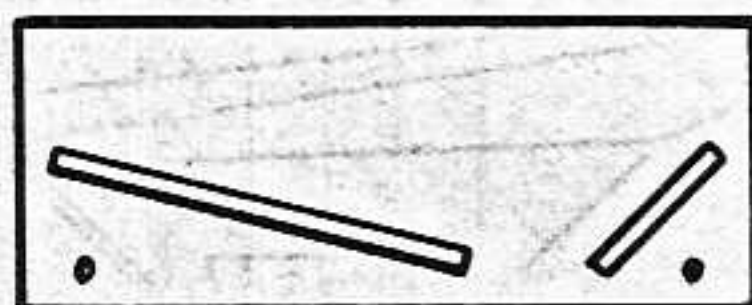

OLD STYLE

P-229-SM

.25



P-231-SM

.25

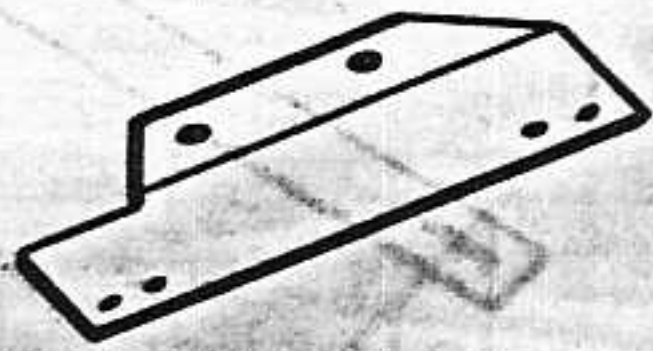

OLD STYLE

P-232-SM

1.00



P-233-SM

1.50



P-234-SM

.50



P-235-SM

NO CHARGE



P-236-SM

2.00

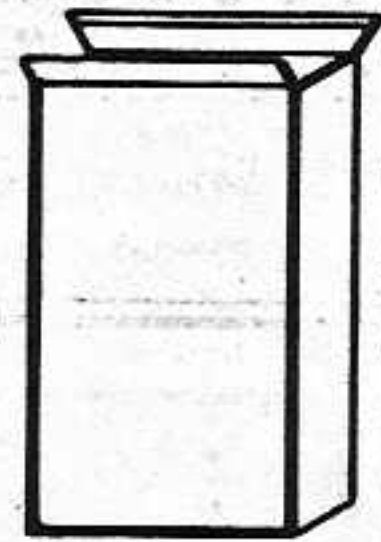

P-237-SM

3.00

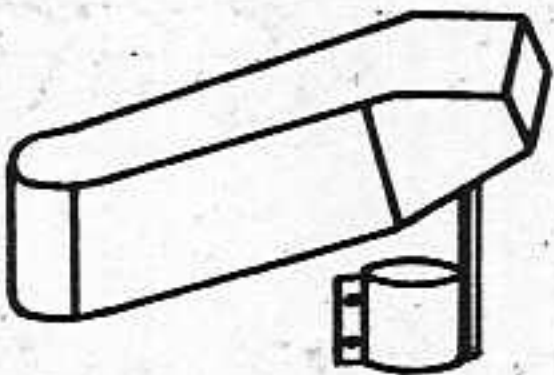

P-273-SM

.50

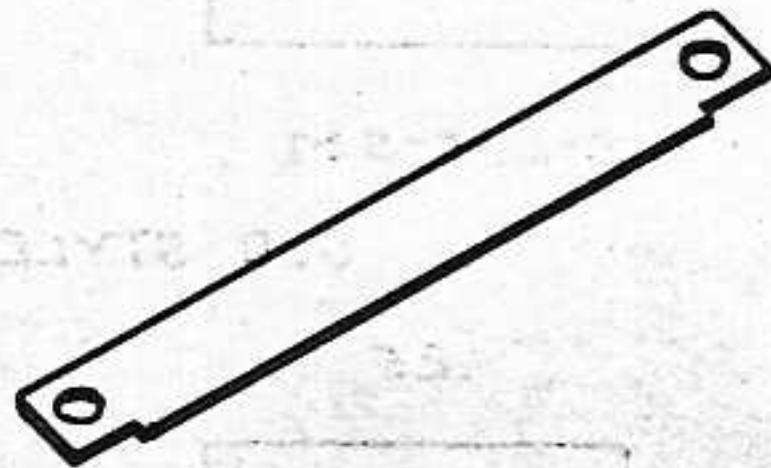

P-243-SM

.50

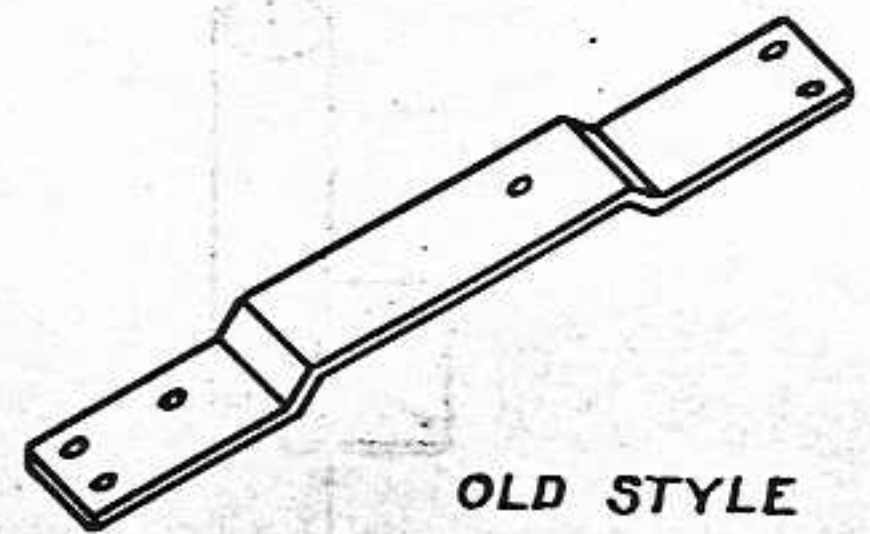

OLD STYLE

P-244-SM

.25



P-246-SM

1.50

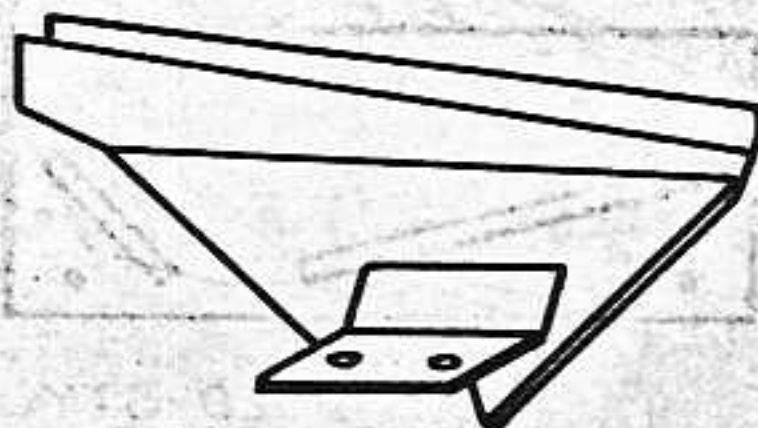

OLD STYLE

P-248-SM

.25



OLD STYLE

P-250-SM

.50

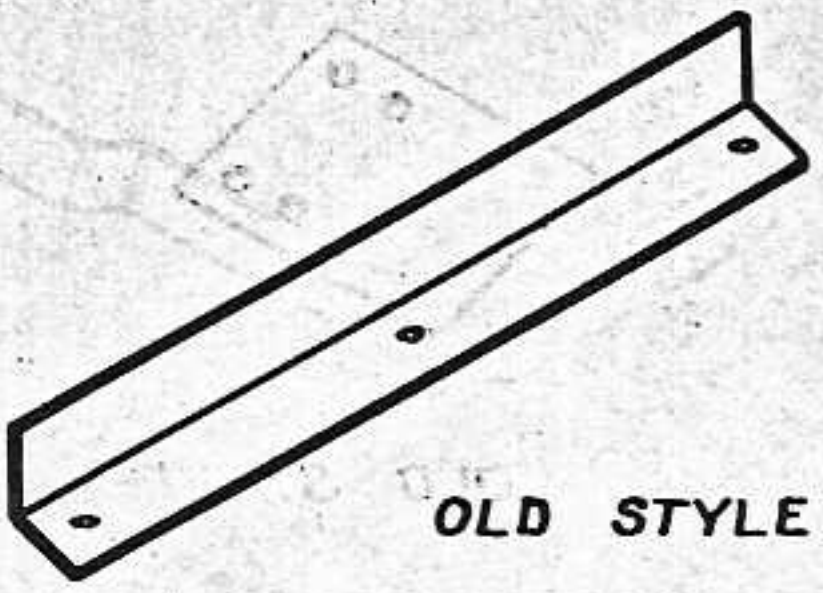

OLD STYLE

P-251-SM

.75



OLD STYLE

P-252-SM

.75

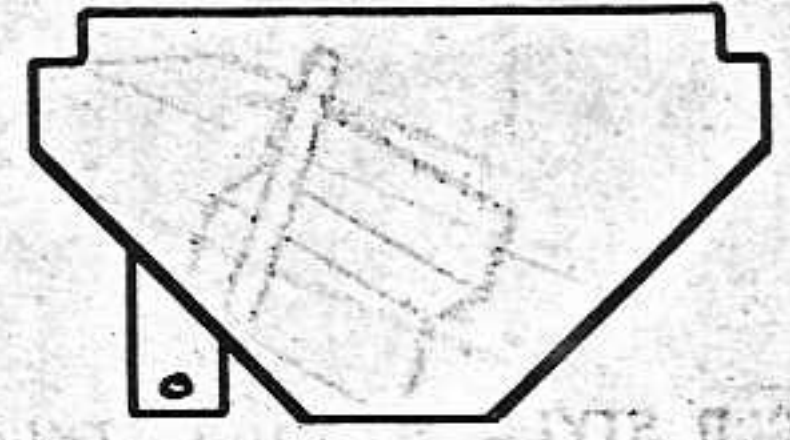

OLD STYLE

P-253-SM

1.00

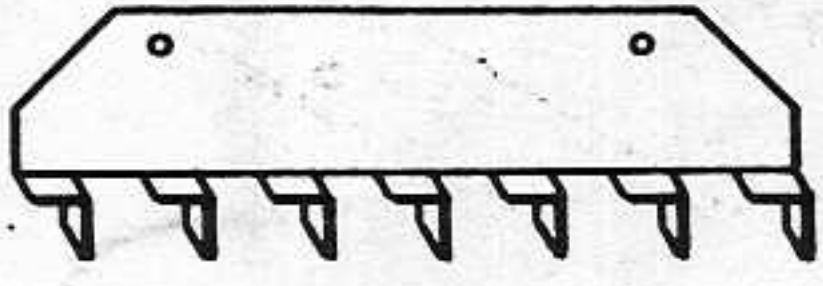

OLD STYLE

P-254-SM

.50



OLD STYLE

P-256-SM

.75

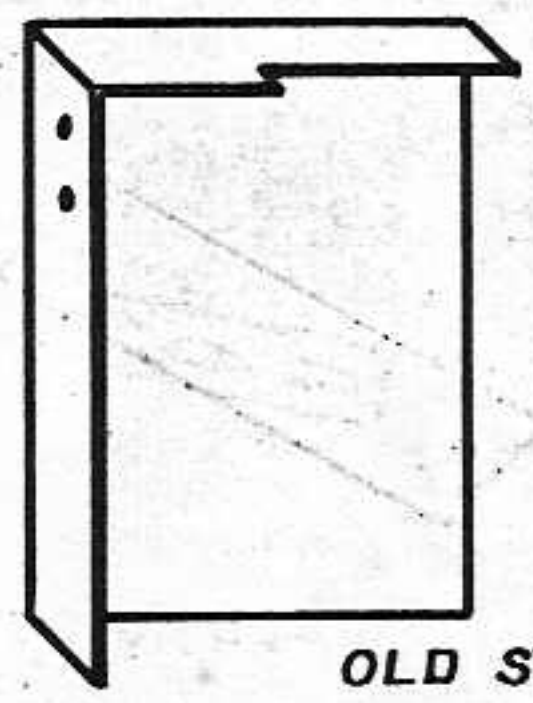

OLD STYLE

P-257-SM

.10



P-258-SM

.50

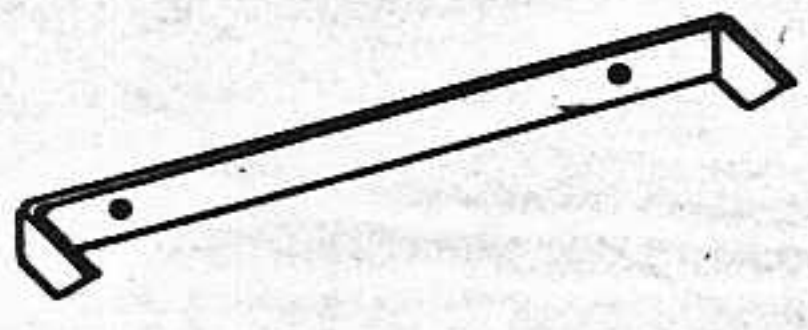

OLD STYLE

P-263-SM

.25

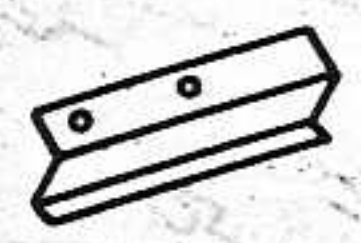

OLD STYLE

P-265-SM

.50

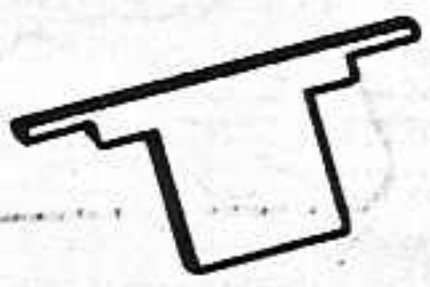

P-266-SM
P-266-A-SM

1.75

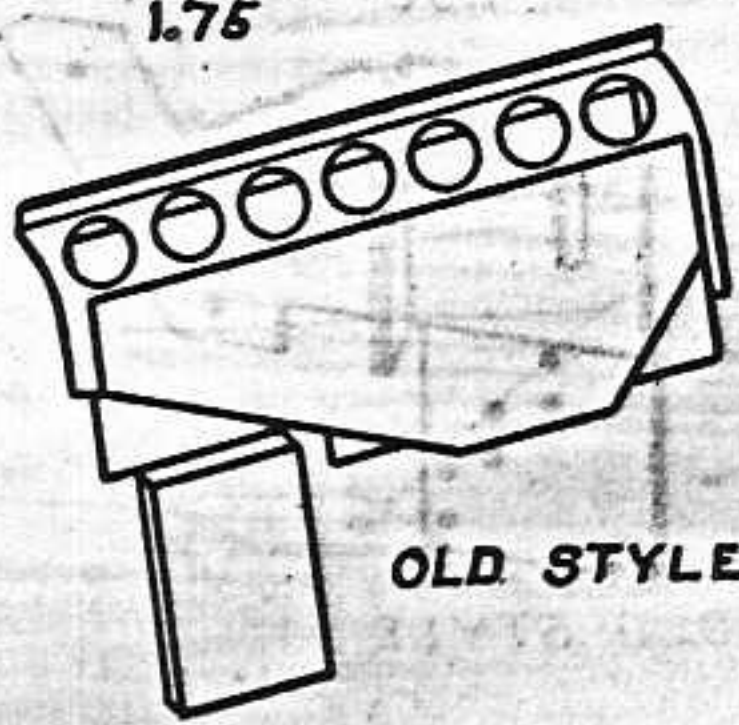

OLD STYLE

P-267-SM

.75



OLD STYLE

P-276-SM

1.00



OLD STYLE

P-277-SM

OLD STYLE

P-278-SM UPPER .10
P-279-SM LOWER .10

.10

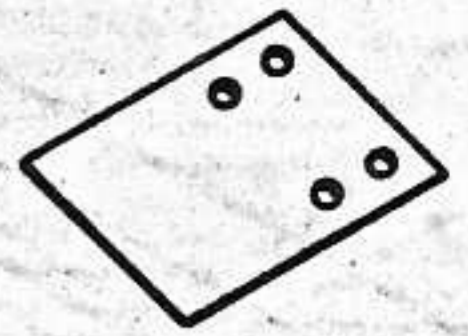

OLD STYLE

P-280-SM

.10

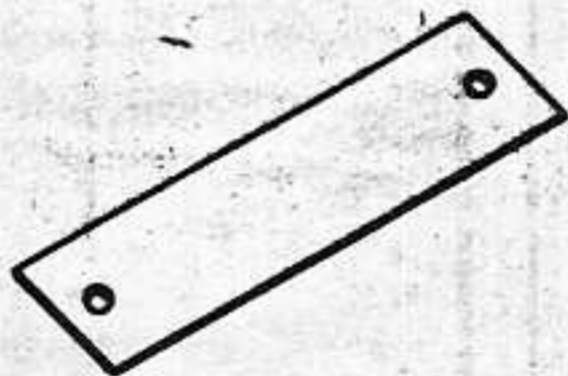

OLD STYLE

P-281-SM

.50

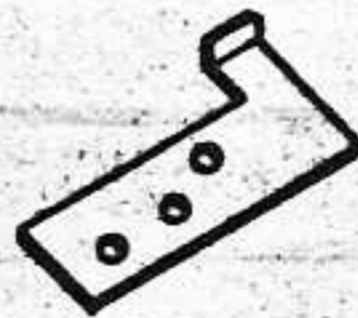

OLD STYLE

P-283-SM

.50

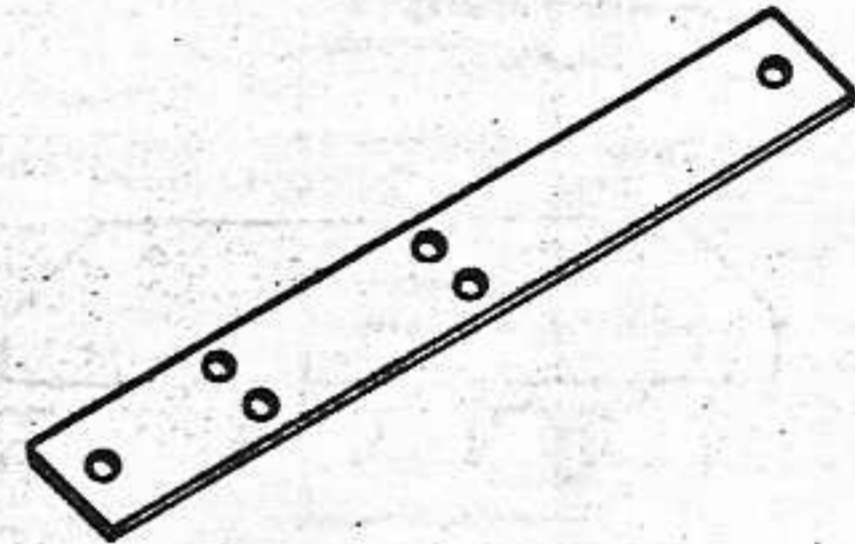

OLD STYLE

P-284-SM

.50

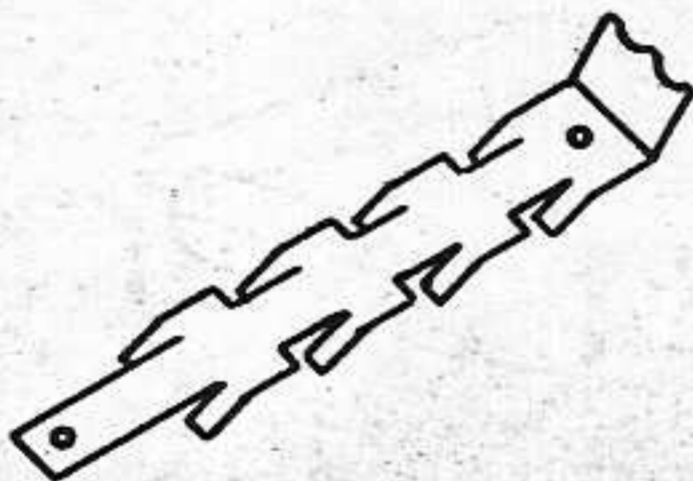

P-337-SM

1.00



P-289-SM

1.50

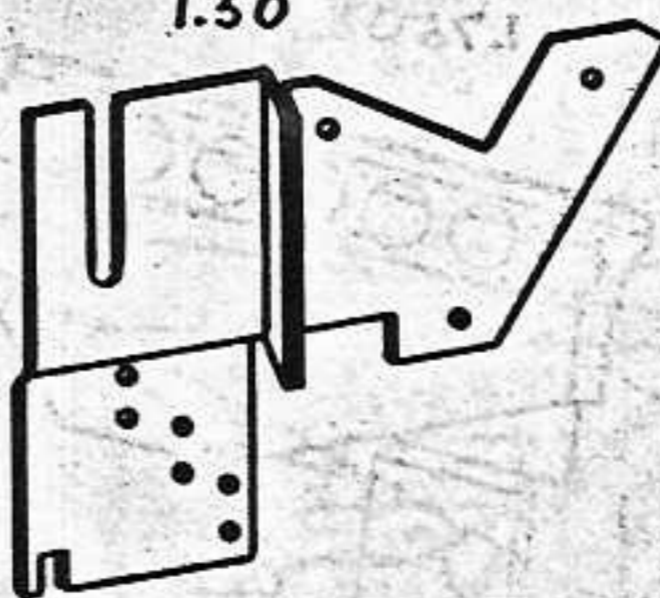

P-290-SM

.75

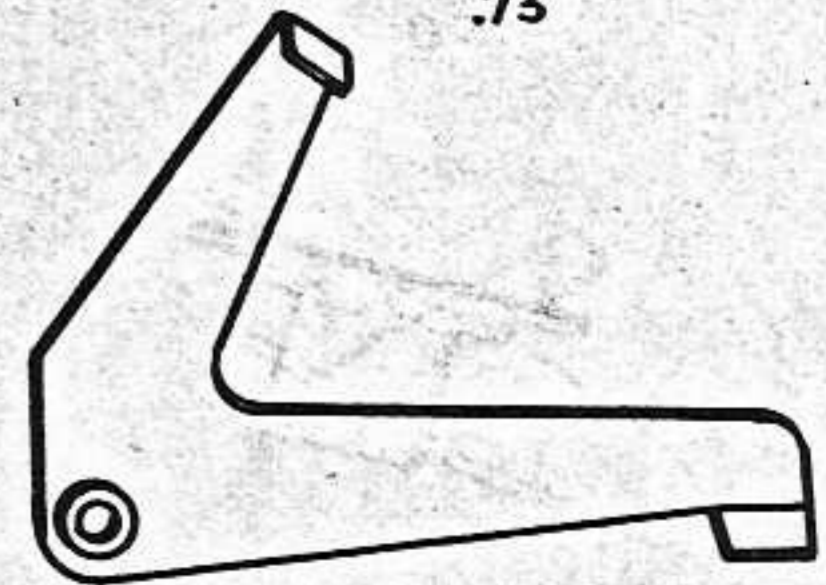

P-291-SM

.50



P-292-SM
.50



P-293-SM
.25

P-295-SM
.50

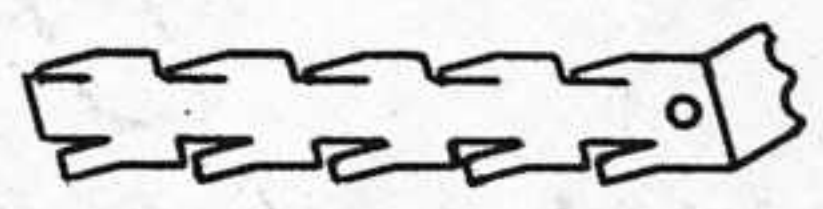

P-296-SM
.50

P-298-SM
.50

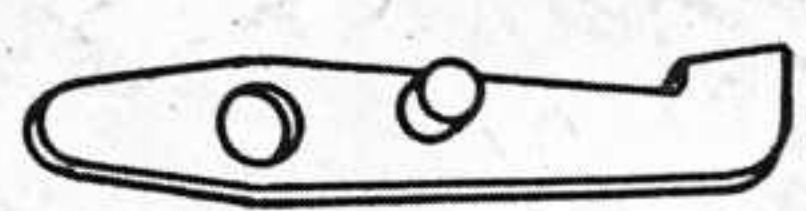
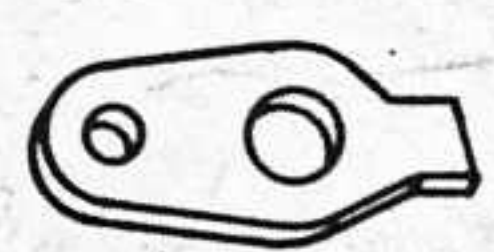

P-299-SM
1.00

P-302-SM

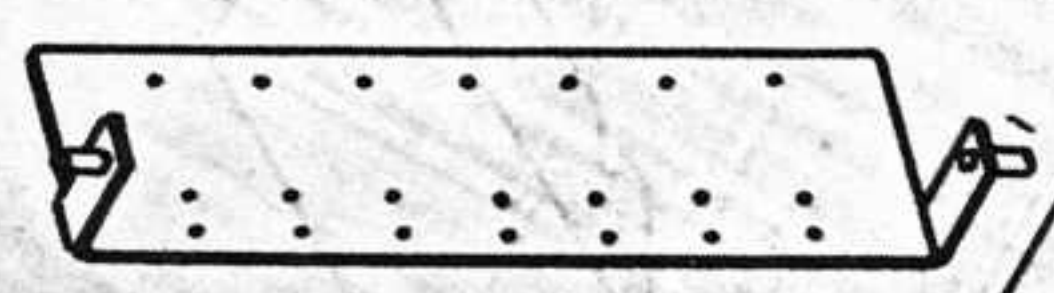

P-300-SM

.75

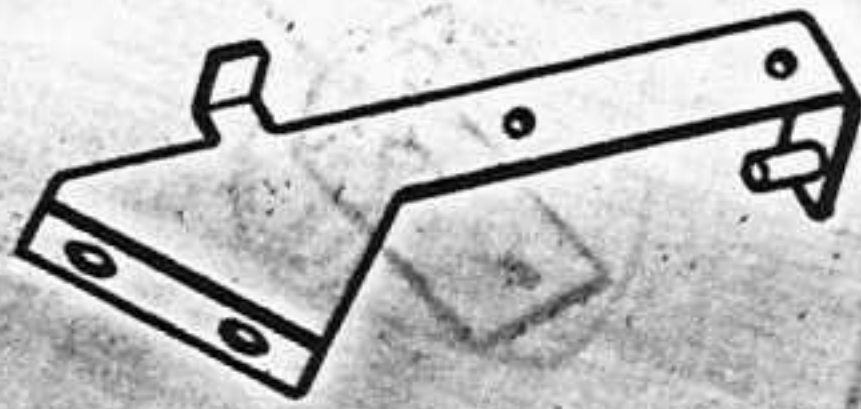

P-307-SM

.50

.25

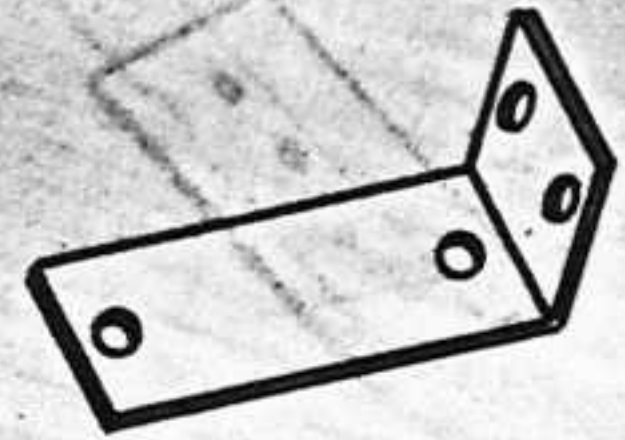

P-308-SM

.50



P-310-SM

.75

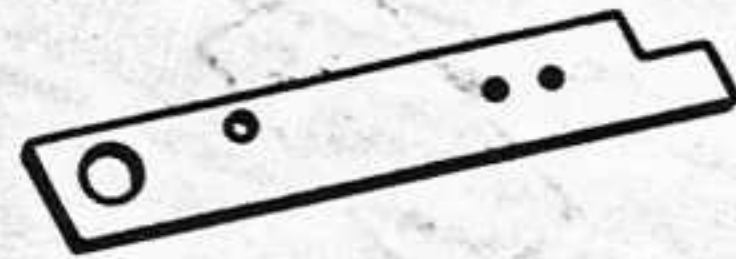

P-311-SM

1.50

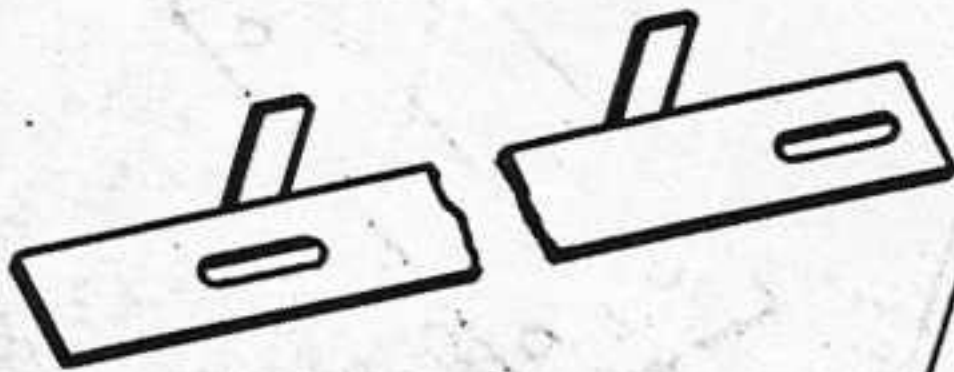

P-313-SM

.50

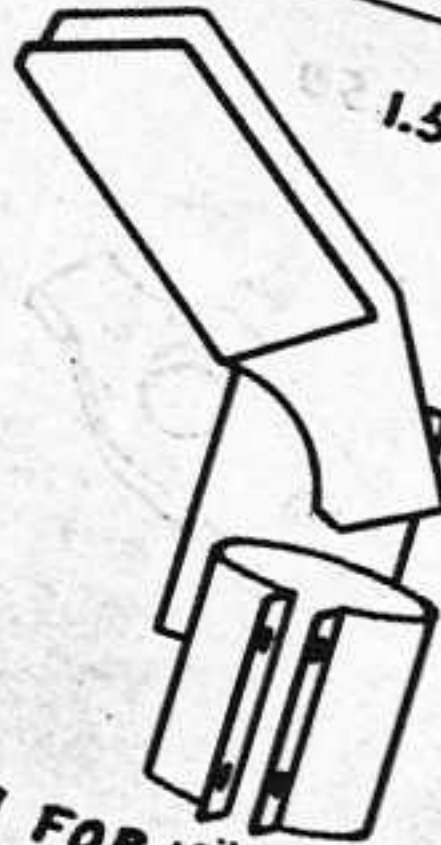

P-314-SM FOR 1 5/16" O.D. TUBE
P-344-SM FOR 1" O.D. TUBE

.25

P-312-SM

2.50

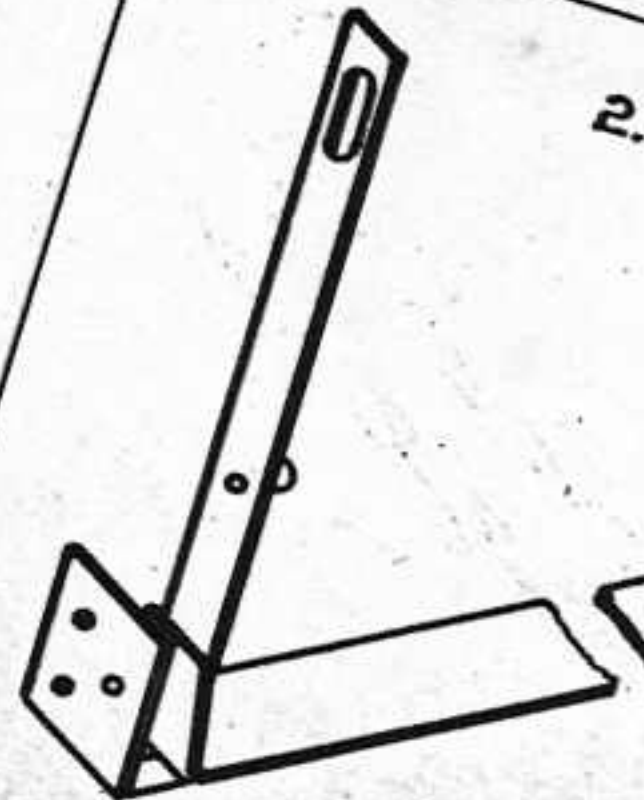

P-312-SM

1.50



P-318-SM

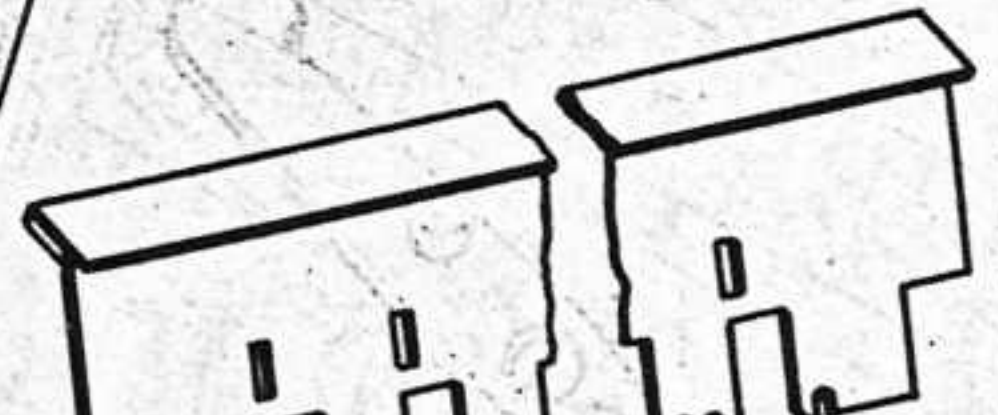
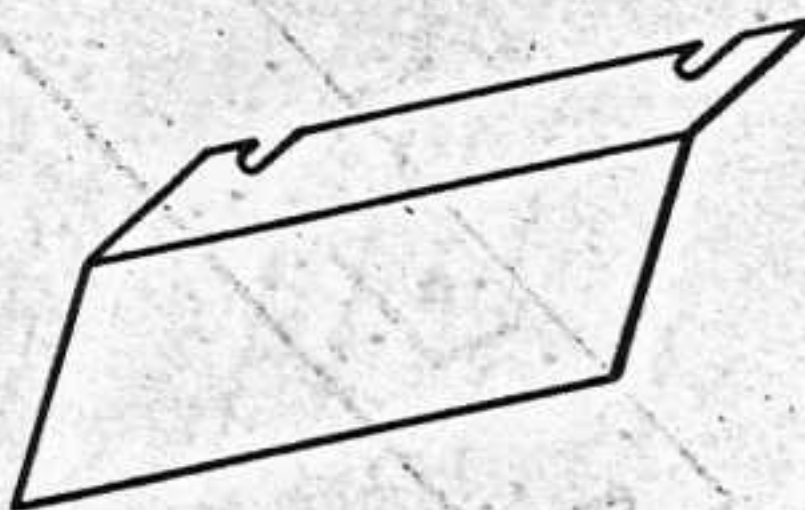

2.00

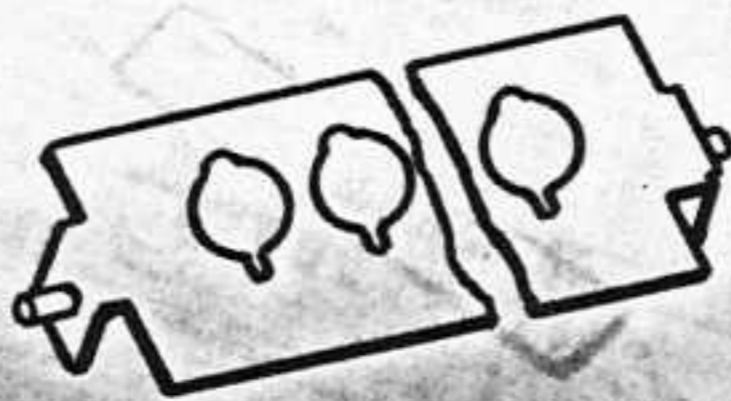

I-36-SM

.50

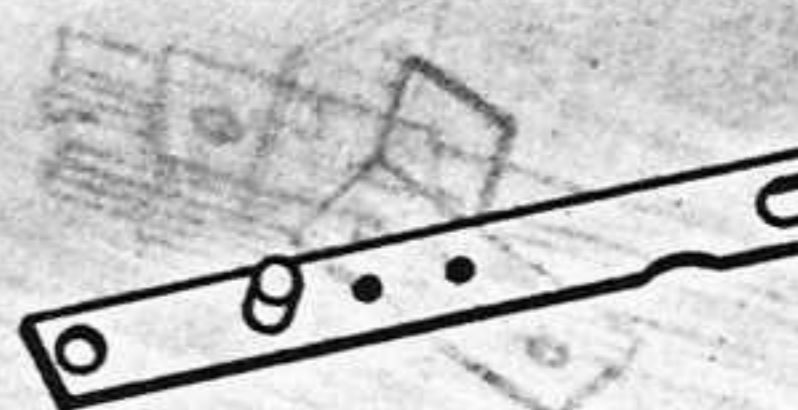

P-322-SM

.10

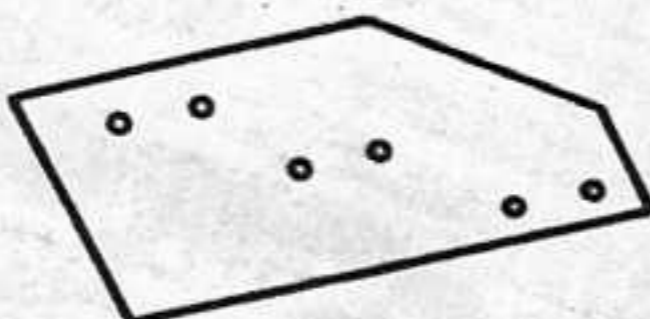

1.50

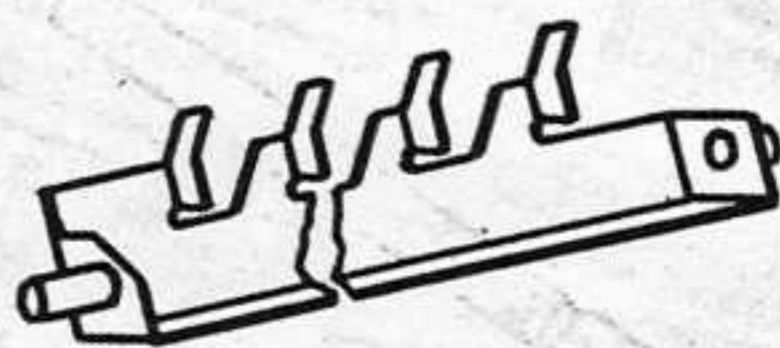

P-326-SM

1.00

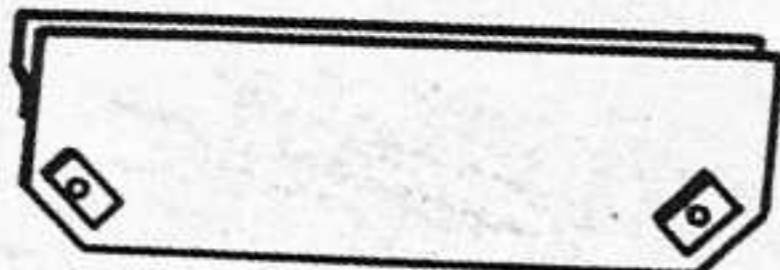

P-327-SM

.75

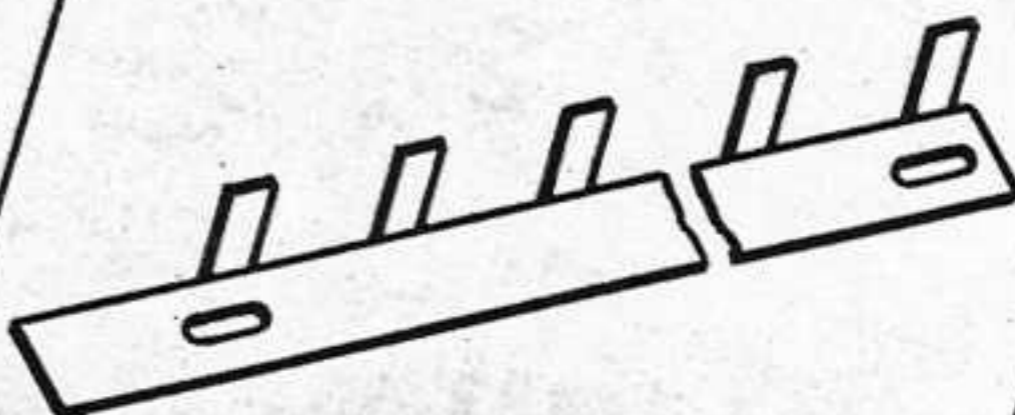

P-329-SM

3.00

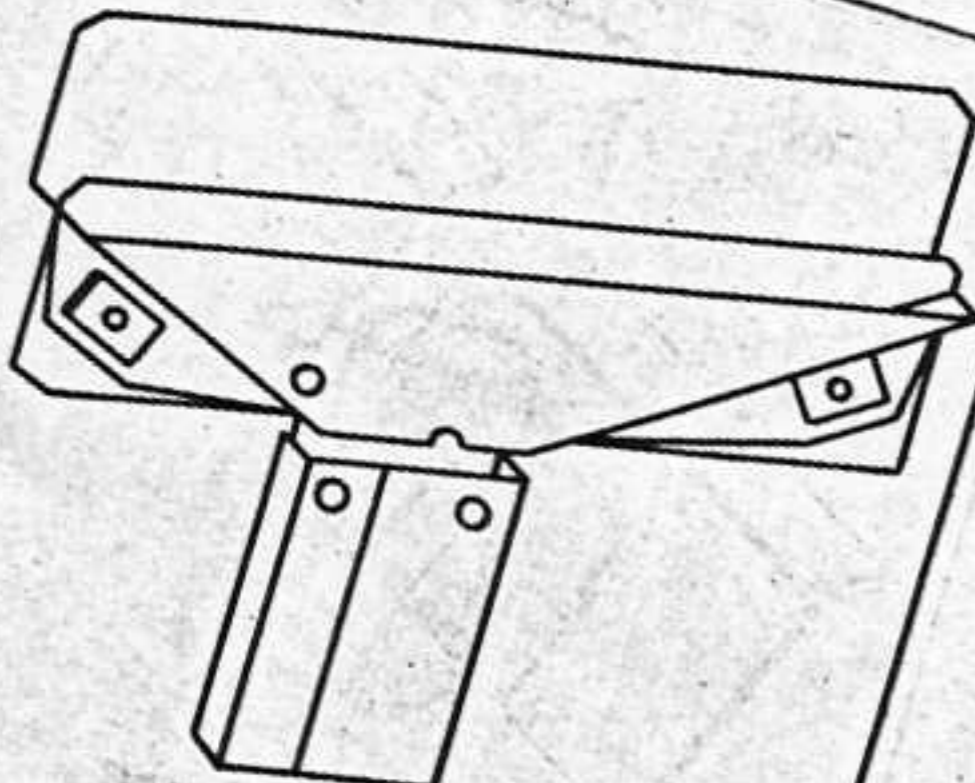

P-333-SM

.25



P-335-SM

.50

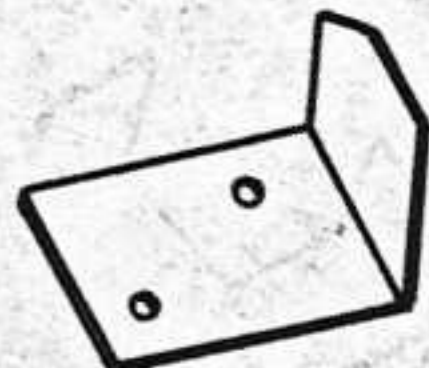

I-42-SM

P-341-SM

.50

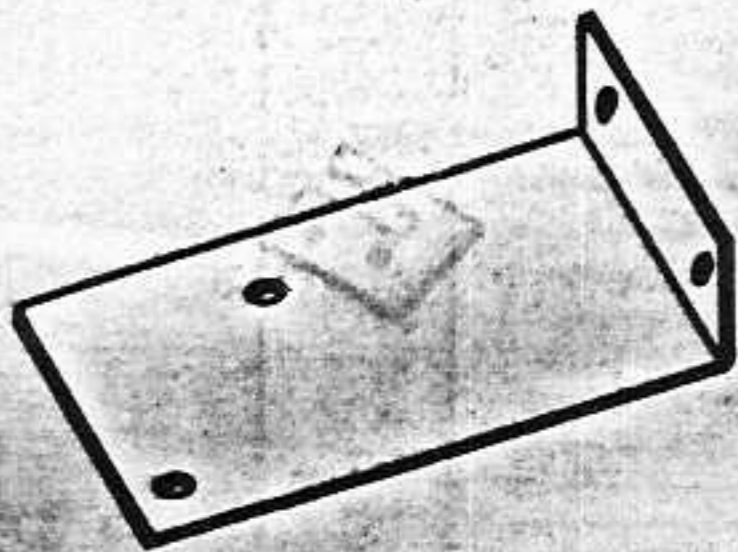

P-345-SM

.25

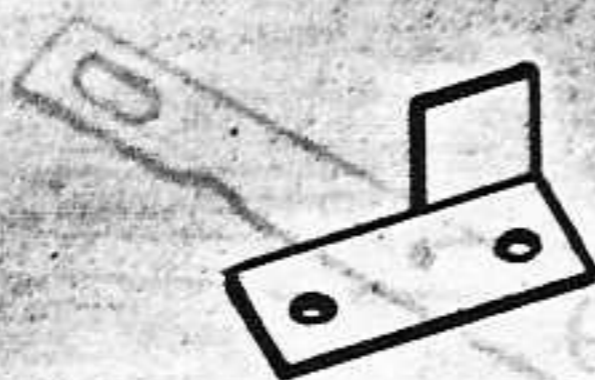

P-346-SM

.25



P-347-SM

.50

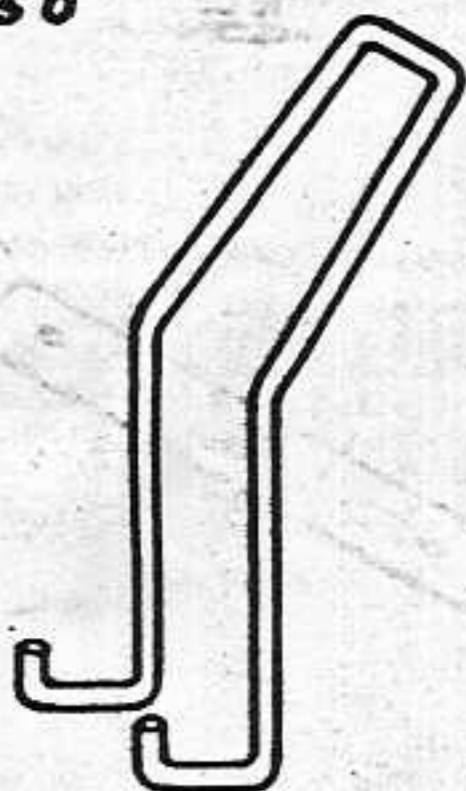

I-45-SM

.25



M-233-SM



P-345-SM

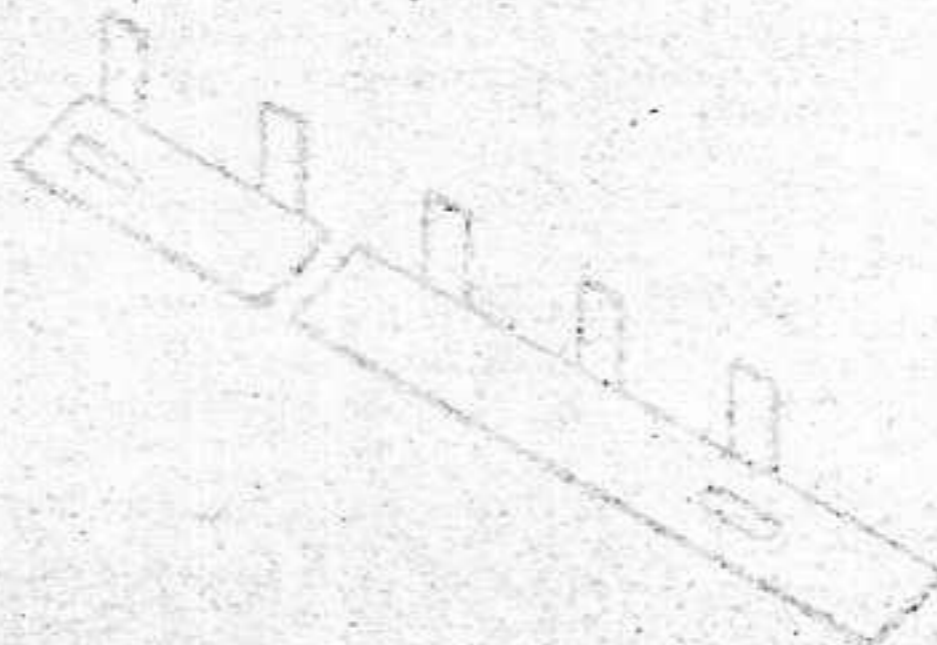

P-346-SM



P-347-SM

.25



P-345-SM

.25



P-346-SM

.25

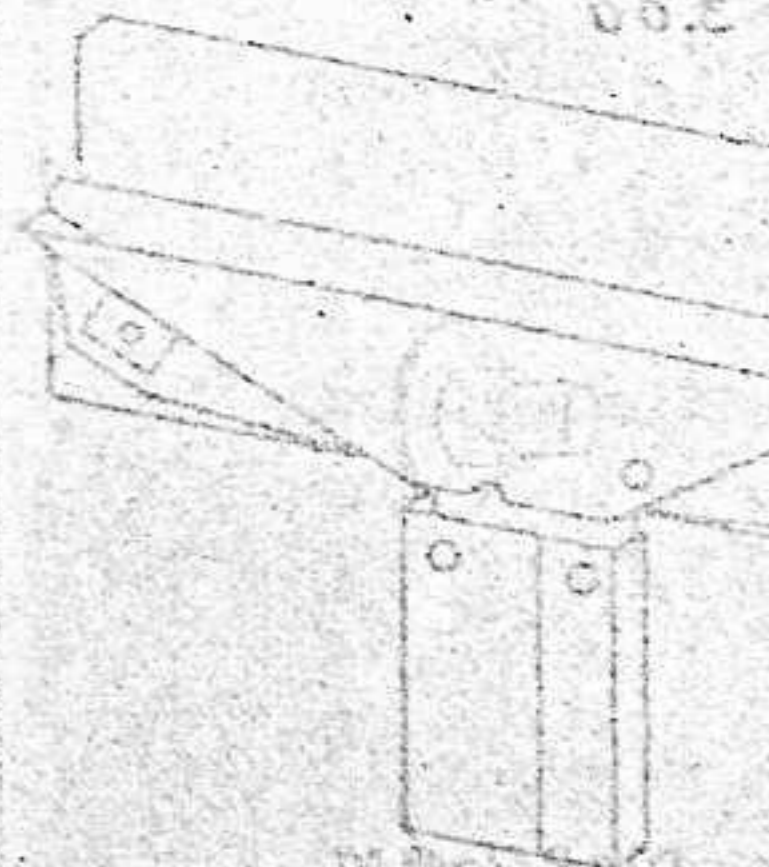

P-347-SM

.25

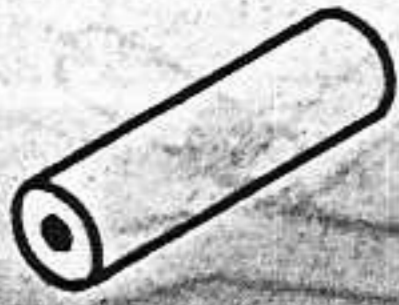

M-200-SM

.50



M-201-SM

.75



OLD STYLE

M-202-SM

.75

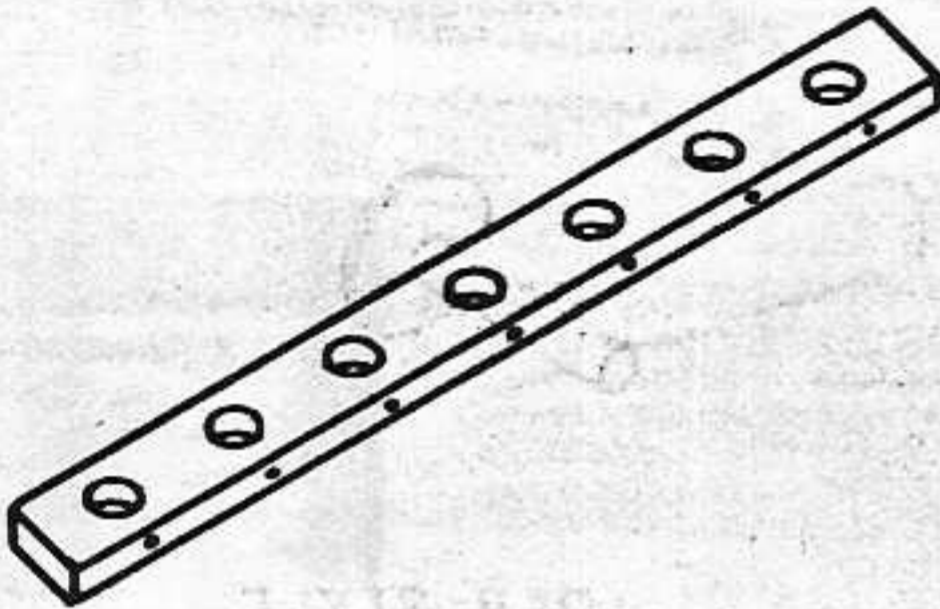

M-203-SM

NO CHARGE

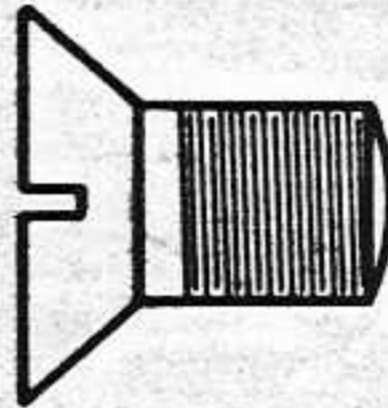

SHOWN FOUR TIMES ACTUAL SIZE

OLD STYLE

M-204-SM

.25



M-205-SM

.25



M-207-SM

.25

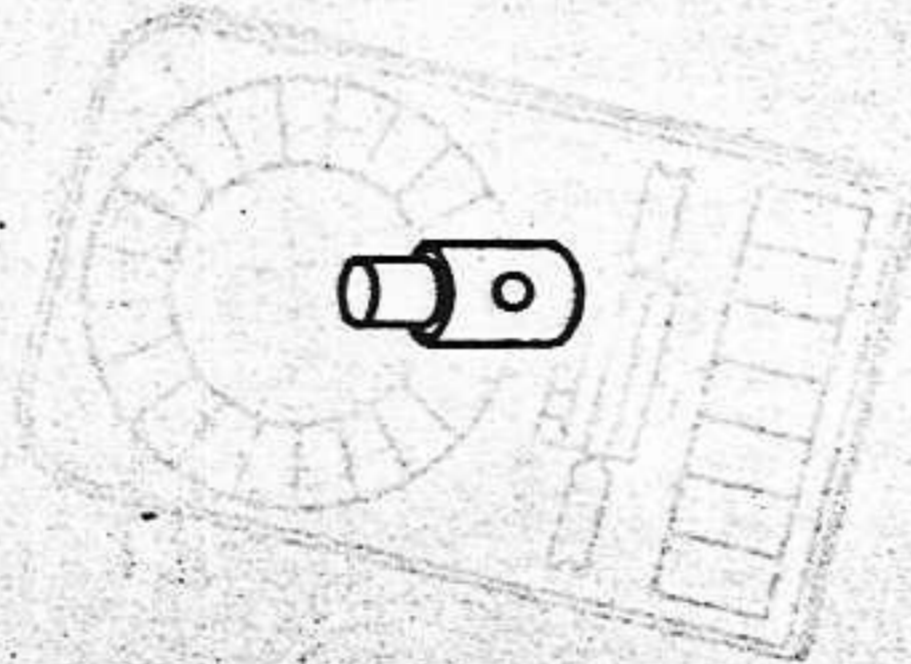

M-209-SM

.25



M-210-SM

.25



M-211-SM

.25



OLD STYLE

M-212-SM

.25

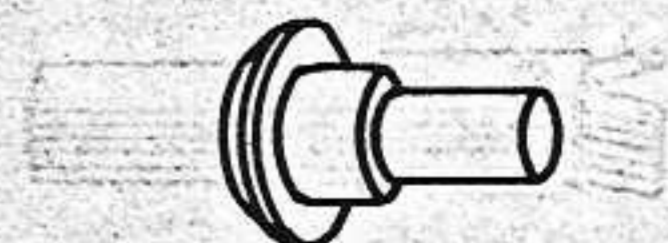

M-213-SM

.75



M-215-SM

.25

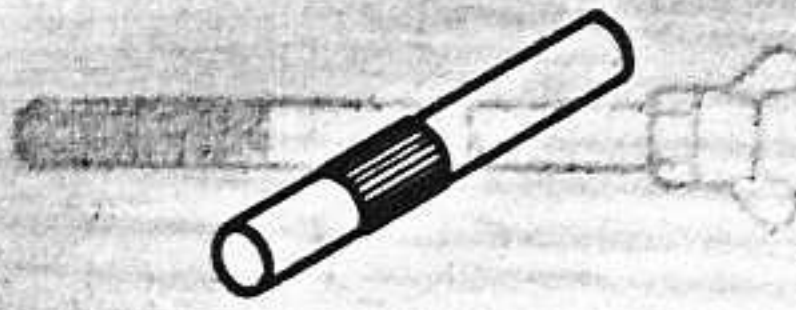

M-216-SM

.25



M-217-SM

.25

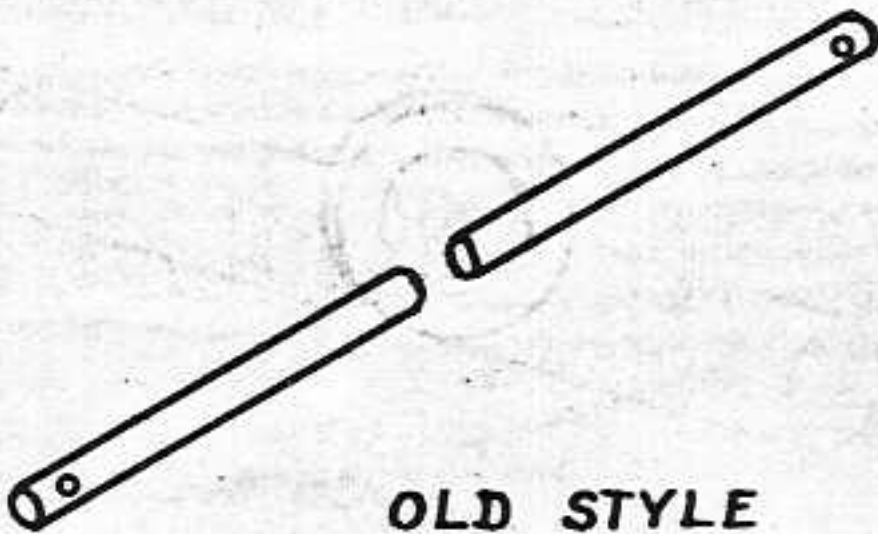

OLD STYLE

M-218-SM

.25



OLD STYLE

M-219-SM

.25



OLD STYLE

M-221-SM

.25



.75 I-1-SM OLD STYLE
.75 I-34-SM NEW STYLE

2500

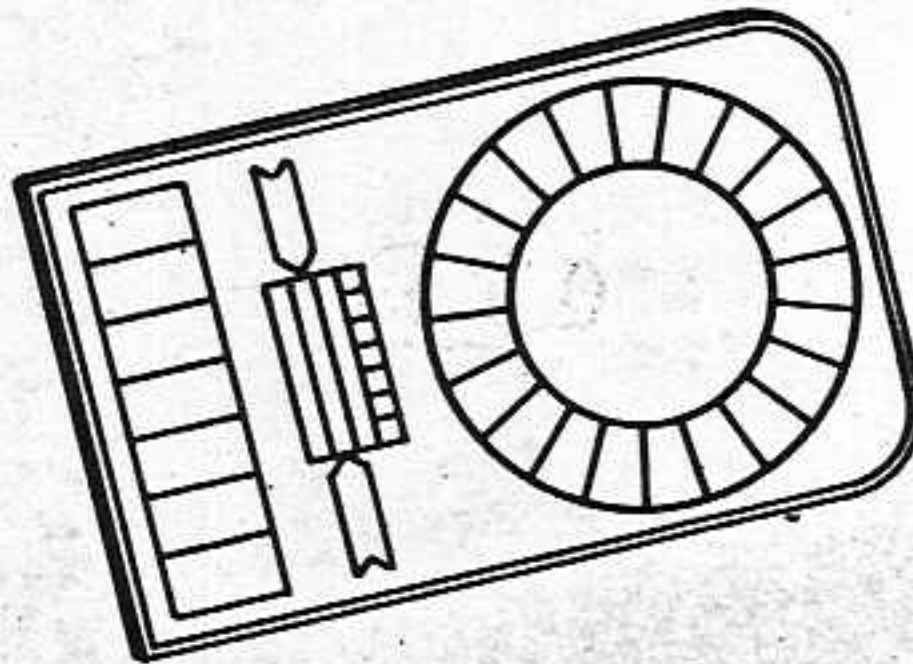

GLASS ONLY

.10

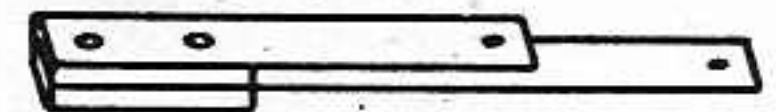

S-1-S

.50

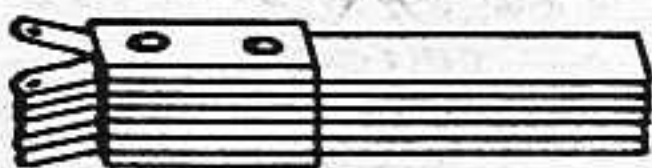

S-2-S

.10



S-3-S

.10

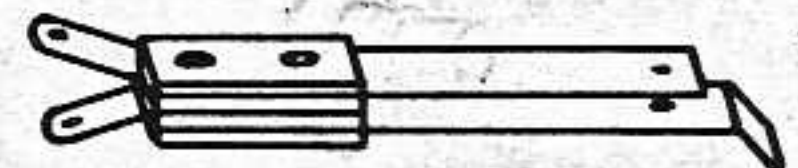

S-4-S

.50

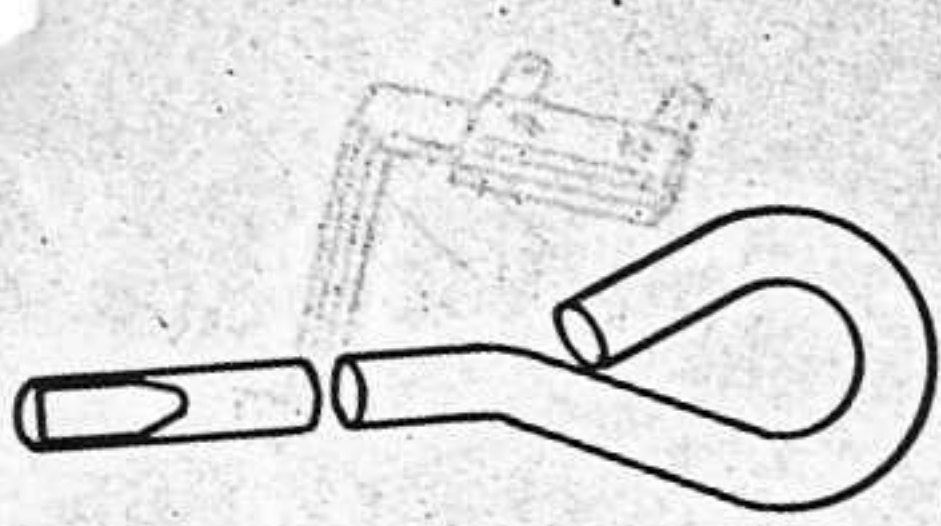

M-230-SM

.25



M-231-SM

.50

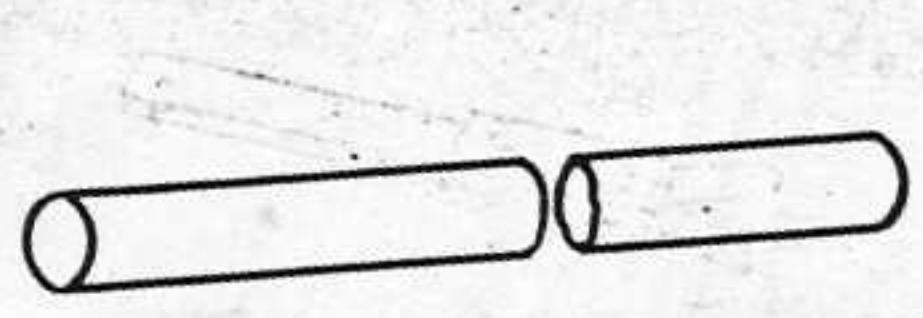

M-238-SM

.25

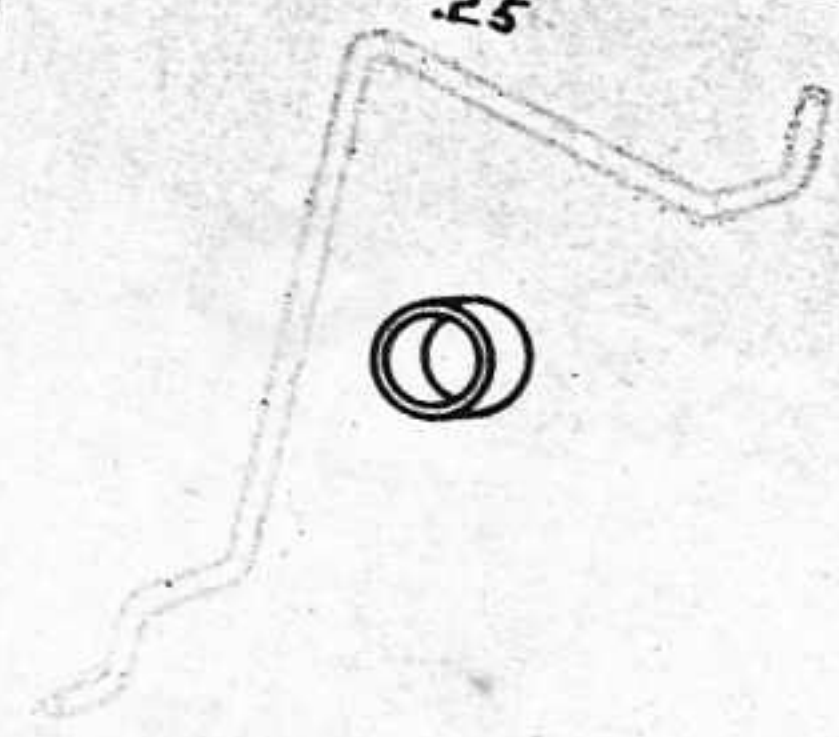

M-240-SM

M-232

.50

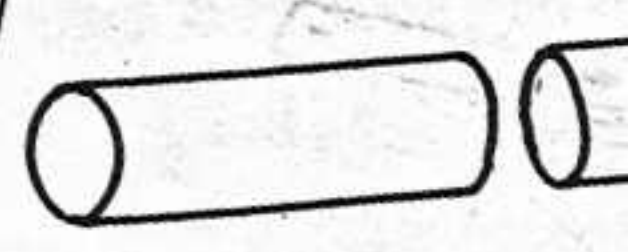

M-241-SM

.50

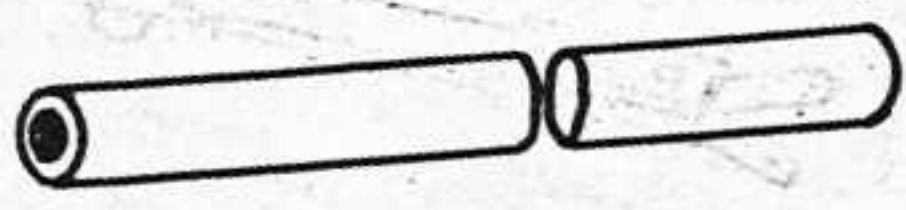

M-246-SM

.25



M-259-SM

.25

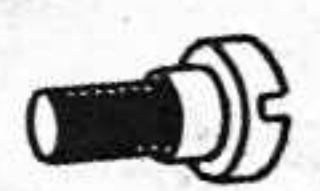

M-260-SM
M-262-SM

.25



.25



.25



M-261-SM

.10



S-5-S

.15

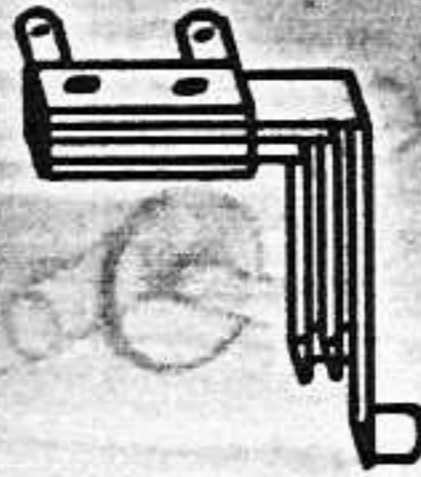

OLD STYLE

S-6-S

.15

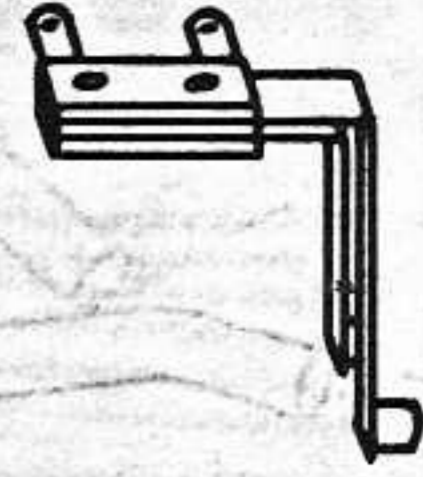

OLD STYLE

S-7-S

.10



S-8-S

.10

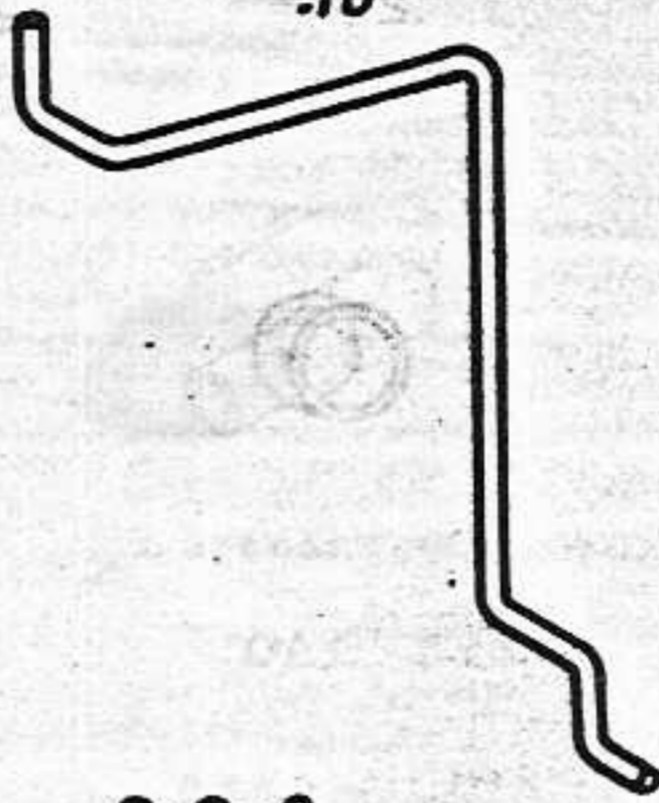

S-9-S

.10

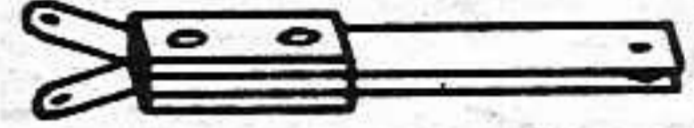

S-10-S

.10



OLD STYLE

S-11-S

.15

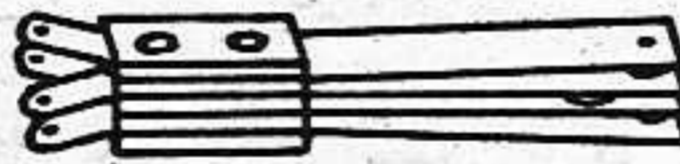

OLD STYLE

S-13-S

.15

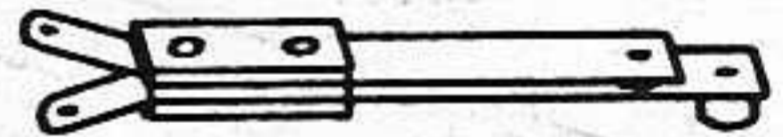

OLD STYLE

S-12-S

S-14-S

.10

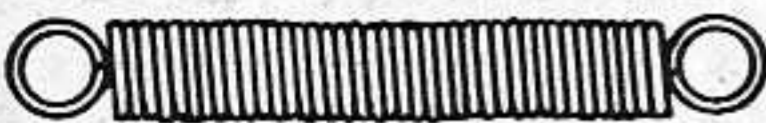

OLD STYLE

S-15-S

.10



S-17-S

.10



S-18-S

.10

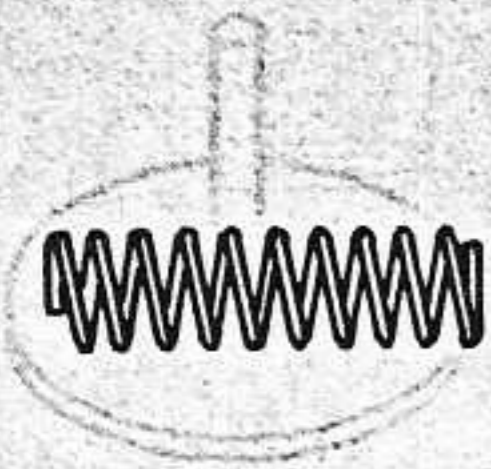

S-19-S

.50

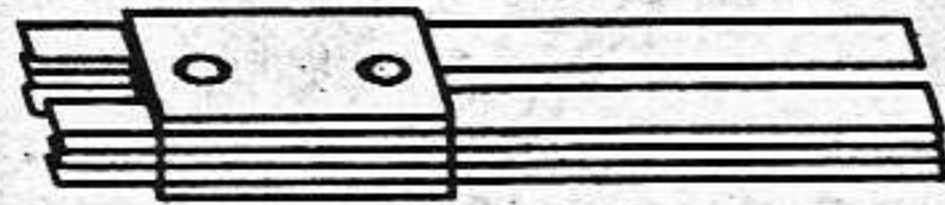

S-20-S

.10



S-21-S	S-26-S
S-22-S	S-27-S
S-23-S	S-28-S
S-24-S	S-29-S
S-25-S	S-30-S

.10

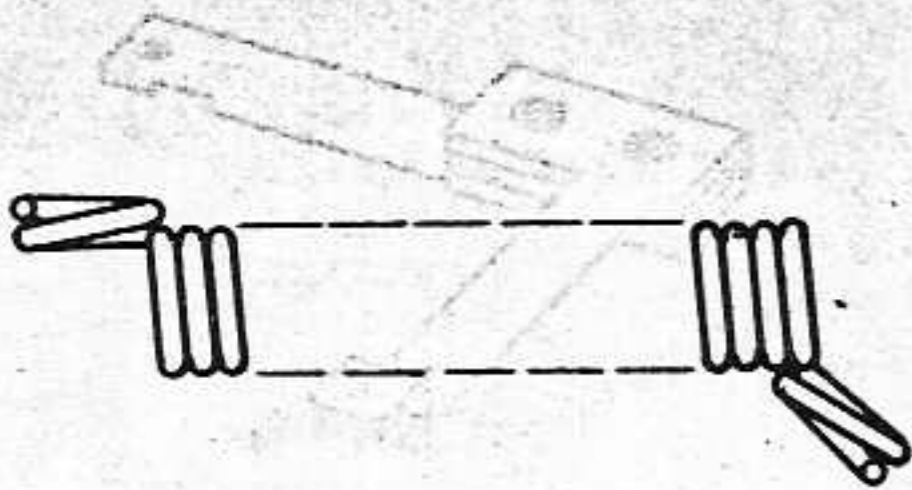

S-31-S

.10

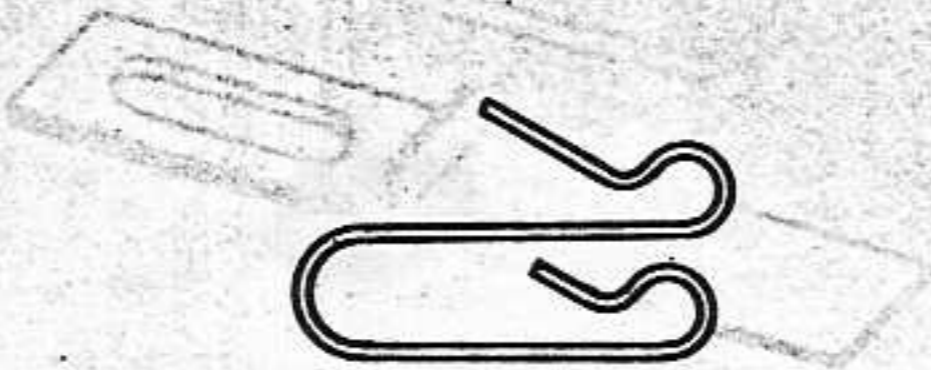

SHOWN DOUBLE SIZE

S-33-S

.35

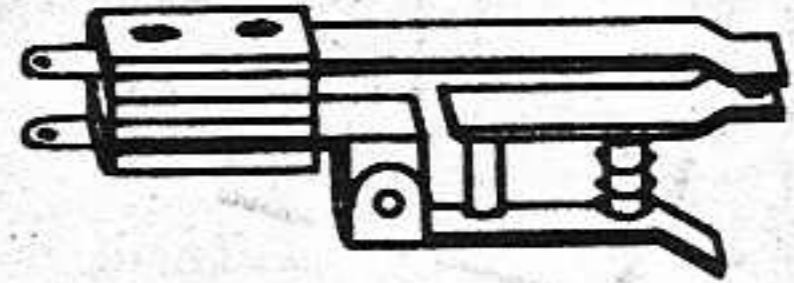

S-32-S

.35

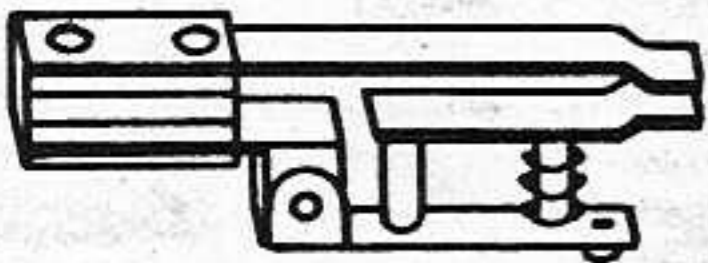

S-34-S

.10



S-306-PM

1.50

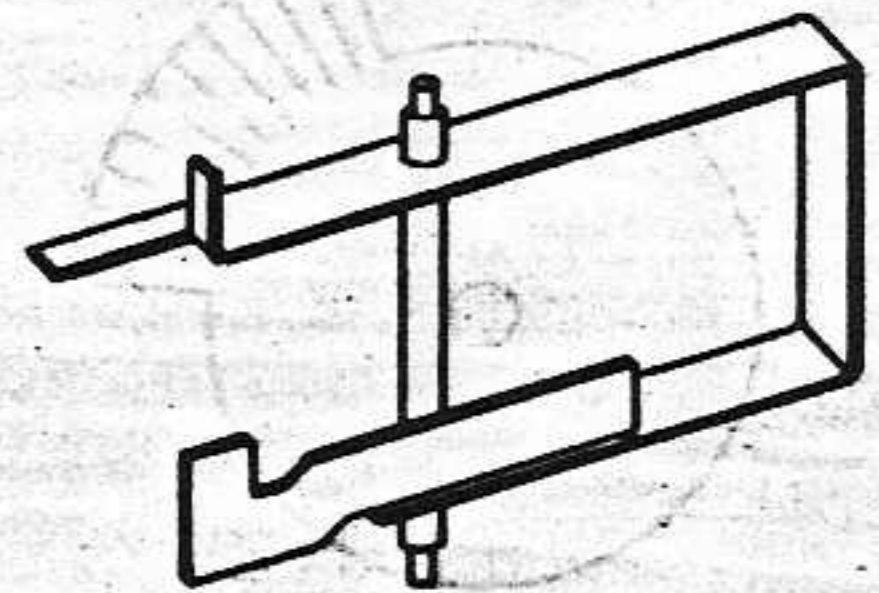

P-207-PM

.75



M-139-PM

.25



M-138-PM



1.50

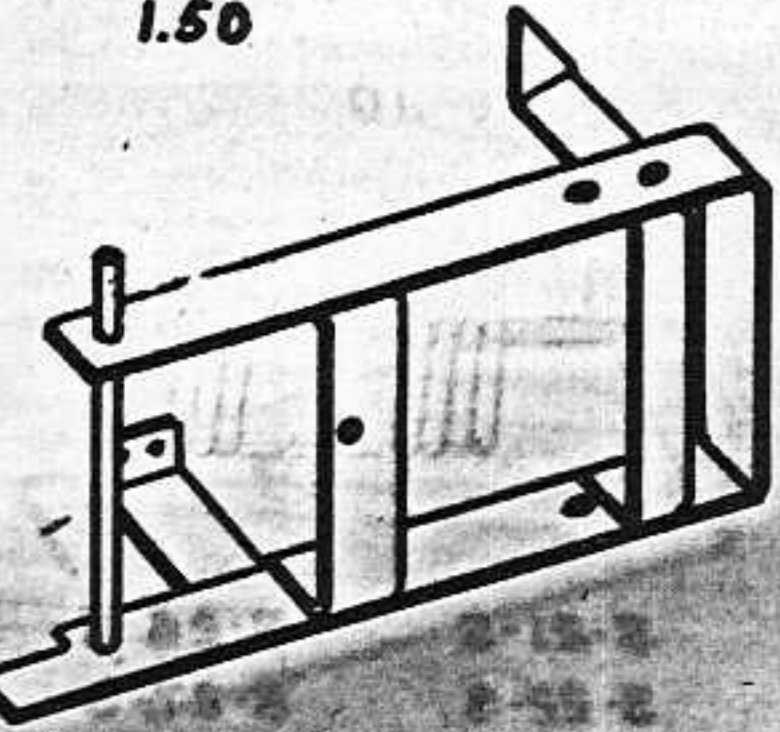

P-203-PM

.50

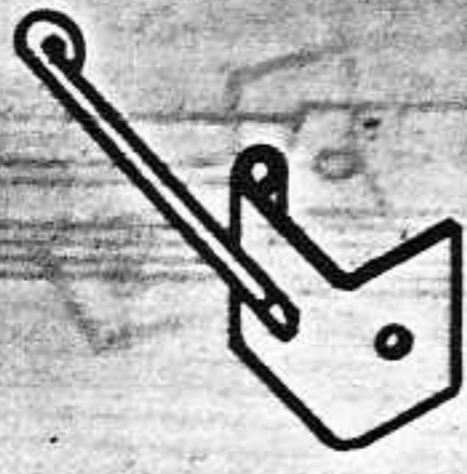

P-261-PM

.50

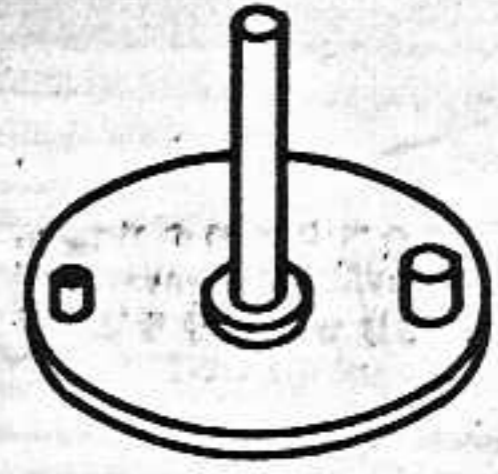

P-213-PM

.50

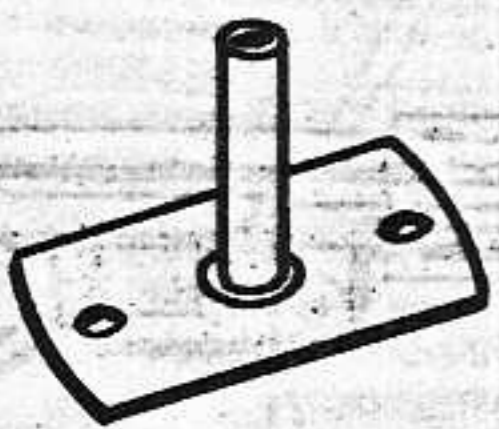

M-135-PM

.25

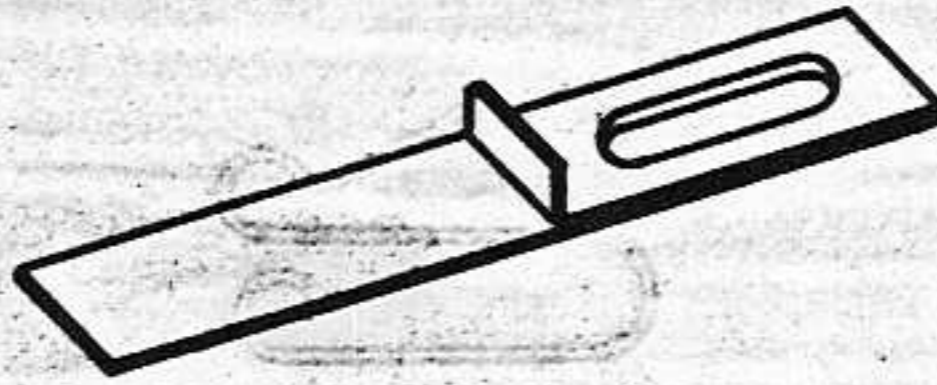

P-223-PM

.25

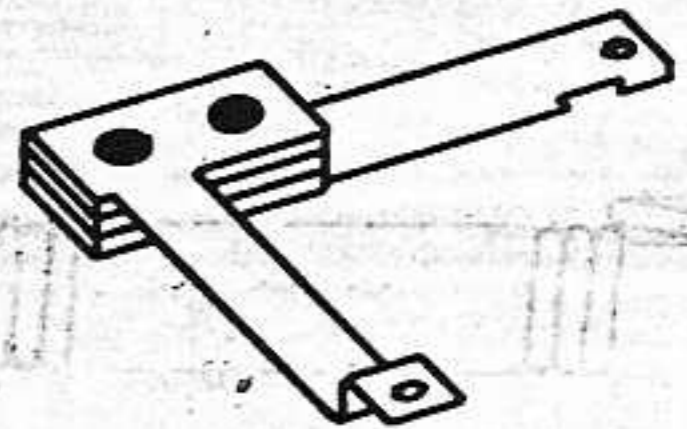

S-308-PM

1.00

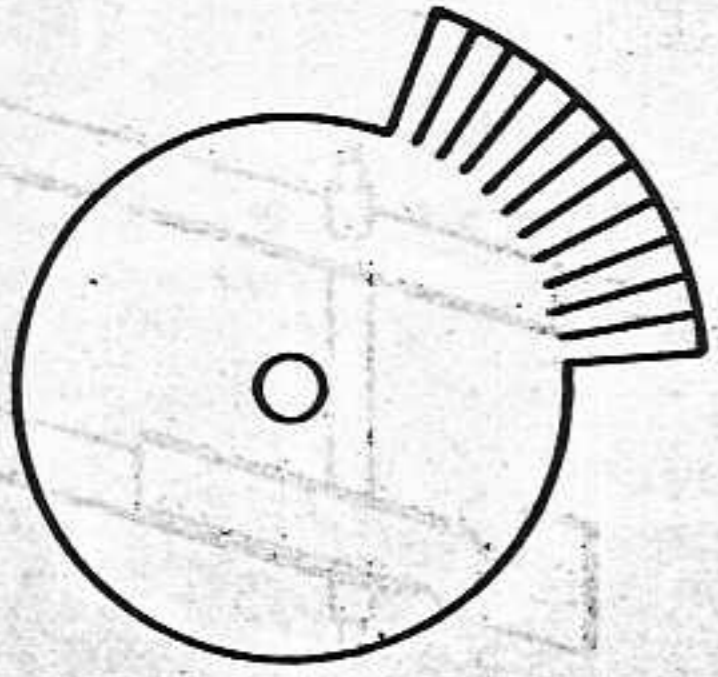

P-200-PM

.10

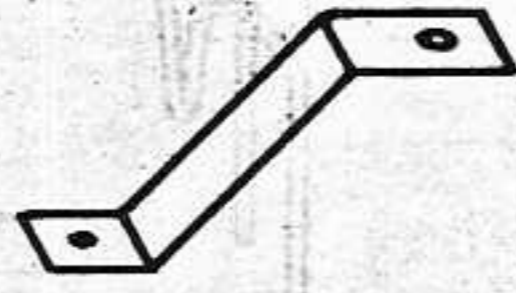

S-316-PM

.10

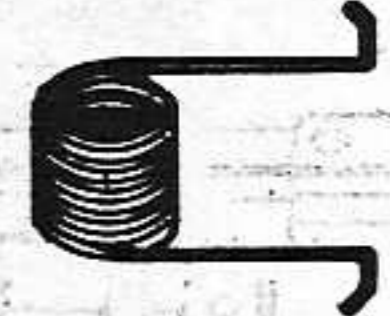

S-307-PM

.10

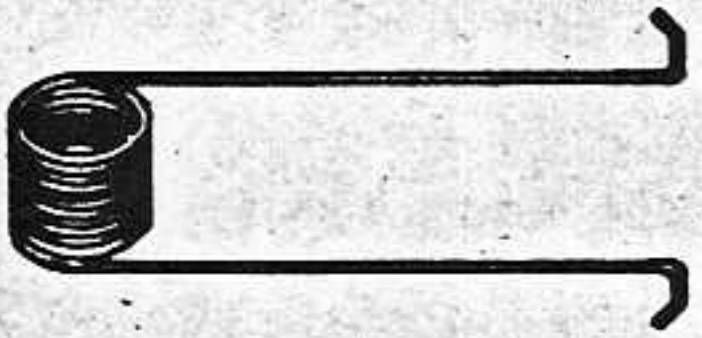

S-313-PM

.10



S-300-PM

.10

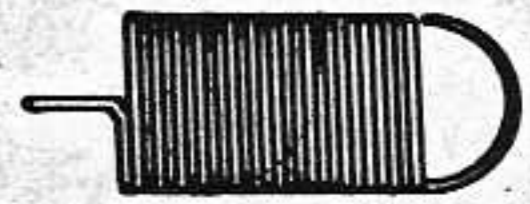

S-301-PM

Skeleton view of the all steel, electrically welded cabinet used on Buckley console machines, showing its rigid, sky-scraper construction.

