



*Bally* MIDWAY

# FOOTBALL



## Parts and Operating Manual



*Bally*

MIDWAY MFG. CO.

10601 W. Belmont Avenue  
Franklin Park, Illinois 60131  
U.S.A.



Phone: (312) 451-9200    Cable Address: MIDCO    Telex No.: 72-1596

**WARNING**

**THIS GAME MUST BE GROUNDED. FAILURE TO DO SO MAY RESULT IN DESTRUCTION TO ELECTRONIC COMPONENTS.**

**WARNING:** This equipment generates, uses, and can radiate radio frequency energy and if not used in accordance with the instructions manual, may cause interference to radio communications. It has been tested and found to comply with the limits for a CLASS A computing device pursuant to SUBPART J of PART 15 of FCC RULES, which are designed to provide reasonable protection against such interference when operated in a commercial environment. Operation of this equipment in a residential area is likely to cause interference in which case the user at his own expense will be required to take whatever measures may be required to correct the interference.

**ELECTRICAL BULLETIN:** FOR ALL APPARATUS COVERED BY THE CANADIAN STANDARDS ASSOCIATION (CSA) STANDARD C22.2 NO. 1, WHICH EMPLOYS A SUPPLY CORD TERMINATED WITH A POLARIZED 2-PRONG ATTACHMENT PLUG.

**CAUTION:** TO PREVENT ELECTRIC SHOCK DO NOT USE THIS (POLARIZED) PLUG WITH AN EXTENSION CORD, RECEPTACLE OR OTHER OUTLET UNLESS THE BLADES CAN BE FULLY INSERTED TO PREVENT BLADE EXPOSURE.

**ATTENTION:** POUR PREVENIR CHOCS ELECTRIQUES NE PAS UTILISER CETTE FICHE POLARISEE AVEC UN PROLONGATEUR. UNE PRISE DE COURANT OU UNE AUTRE SORTIE DE COURANT, SAUF SI LES LAMES PEUVENT ETRE INSEREES A FOND SANS EN LAISSER AUCUNE PARTIE A DECOUVERT.

**Bally MIDWAY**<sup>TM</sup>

*Invites You To Use*

**OUR TOLL FREE NUMBERS FOR  
SERVICE INFORMATION CONCERNING THIS GAME, OR ANY  
OTHER BALLY MIDWAY GAME YOU NOW HAVE ON LOCATION.**

**CALL US FOR PROMPT, COURTEOUS  
ANSWERS TO YOUR PROBLEMS.**

**VIDEO ➡ Continental U.S. 1-800-323-7182**

**PINBALL ➡ Continental U.S. 1-800-323-3555**

**Bally MIDWAY**<sup>TM</sup>

10601 West Belmont Avenue, Franklin Park, Illinois, 60131

phone (312)451-9200

© COPYRIGHT MCMLXXXIII BY BALLY/MIDWAY CO. ALL RIGHTS RESERVED.

NO PART OF THIS PUBLICATION MAY BE REPRODUCED BY ANY MECHANICAL, PHOTOGRAPHIC, OR ELECTRONIC PROCESS, OR IN THE FORM OF A PHONOGRAPHIC RECORDING, NOR MAY IT BE TRANSMITTED, OR OTHERWISE COPIED FOR PUBLIC OR PRIVATE USE, WITHOUT PERMISSION FROM THE PUBLISHER. THIS MANUAL IS FOR SERVICE USE ONLY, AND NOT FOR GENERAL DISTRIBUTION. FOR PERMISSION REQUESTS, WRITE: MIDWAY MFG. CO., 10750 W. GRAND AVE., FRANKLIN PARK, IL 60131

Printed in U.S.A.

## NFL SCORING

DESCRIPTION	POINTS AWARDED
TOUCH DOWN	7 POINTS
FIELD GOAL	3 POINTS

# I LOCATION AND SET-UP

### INSPECTION:

1. Remove the game from its shipping crate.
2. Inspect the entire outside of it for any signs of damage.
  - Any scratches?, dents?, cracks?
  - Any broken controls?
  - Any broken glass or plastic?
  - Just look it over closely and make a note of any signs of damage.

3. Remove the shipping cleats from the bottom of the cabinet.

**UPRIGHT MODELS ONLY:** In order to help prevent easy theft of your game, you may wish to remove the Caster Wheel Assemblies from the bottom of your cabinet at this time.

4. Install the four levelers, one at each corner of the cabinet. See Figure 1-1.

Level the cabinet.

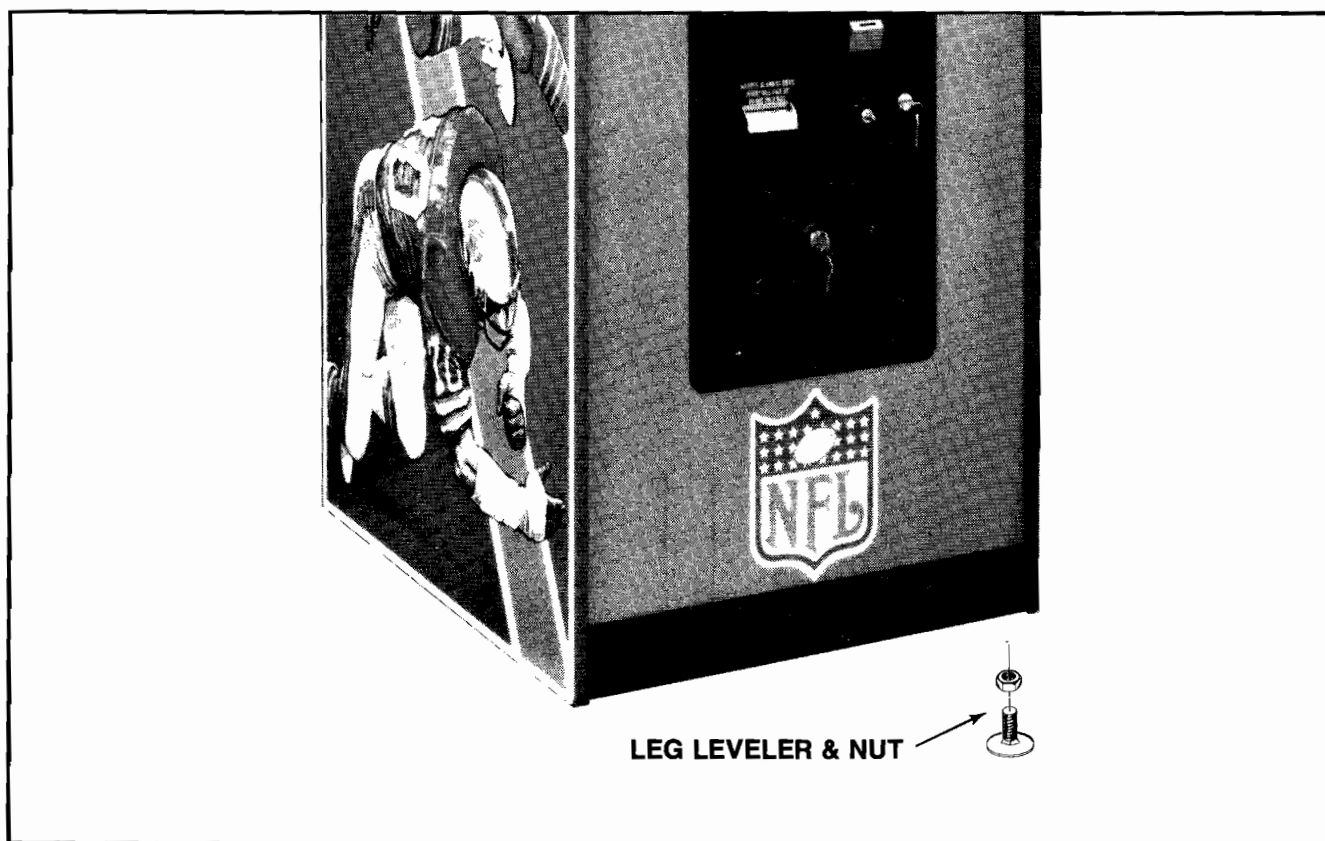

Figure 1-1 Leg Leveler Installation

5. Open the cabinet and inspect the inside of the game for any signs of damage. See Figure 1-2.

Also check to make sure all plug-in connectors on the wire harness are firmly seated.

**NOTE:** ALL connectors or plugs are keyed so they will only go together when all pins are properly lined up.

Re-plug any connectors found unplugged. **DO NOT FORCE PLUGS ONTO CONNECTORS. DO NOT FORCE PLUGS TOGETHER.** If it won't go on easily, assuming the keys are lined up, it either does not belong there or is damaged.

Make sure all printed circuit boards (P.C.B.'s) are firmly seated in their connectors. See Figure 1-2. These connectors are also keyed. The P.C.B.'s will only go in to them one way without being damaged.

Note the location of the games serial number. See Figure 1-2.

Check all major subassemblies to be sure they are mounted securely. These are called out in Figure 1-2.

Power supply.  
Control panel(s).  
T.V. monitor.  
Other P.C.B.'s and/or P.C.B. rack, etc.  
Power Chassis Assembly.  
Video Disc Player.

6. Make a note of any problems that can't be easily corrected.

7. Call your distributor and/or service man about your problem list.

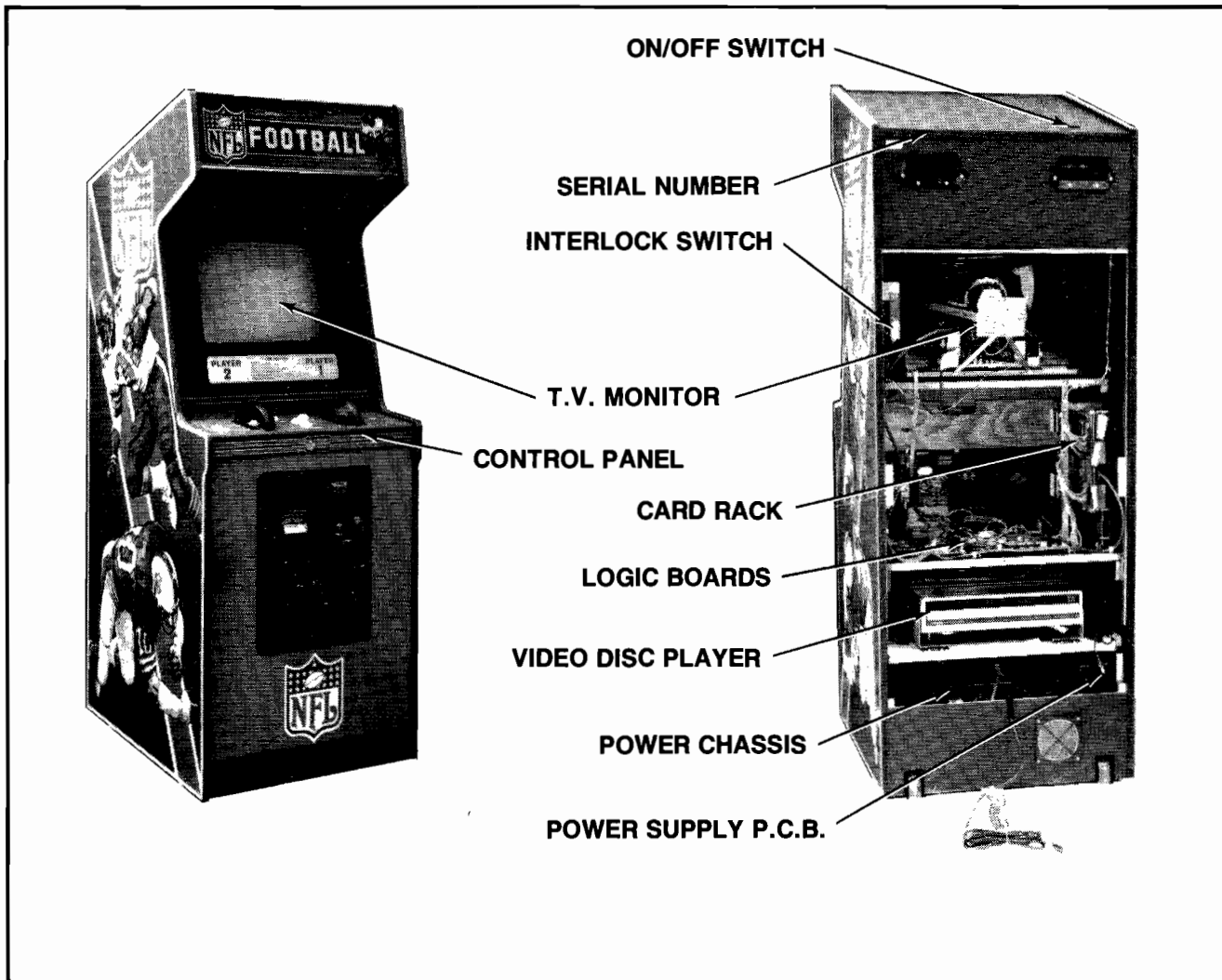

**Figure 1-2 Location of Serial No., Interlock Switch, & Major Sub-Assemblies**

## INSTALLATION:

### 1. Location Requirements:

- Power:  
Domestic 110 V at 60 Hz
- Temperature: 32° to 100°F (0° to 38°C)
- Humidity: Not over 95% relative
- Space required:  
Upright 25" x 34" (63 x 86cm)
- Game height: Upright 74" (188cm) APPROX.

### 2. Voltage Selection:

Your game is designed to work properly on the line voltage where you are located. Check your line voltage with a meter to determine what its value is. Then check the power **input** wires to the main power supply transformer on your game to be sure they are connected to taps which correspond to your line voltage value.

If the power input wires to the main power supply transformer are not connected to taps which correspond to your local line voltage, move them to the proper taps.

If the line voltage in your area falls outside the upper or lower limits of the range of inputs covered by the main power supply transformer, **DO NOT PLUG YOUR GAME IN** until you have talked with your distributor and/or service man and obtained a solution to this problem. Otherwise you could damage your game.

### 3. Interlock and power ON/OFF switches. See Figure 1-2.

- To help prevent the possibility of getting an electric shock while working inside the game cabinet, interlock switches have been installed at each cabinet access door (this **DOES NOT** include the coin door on Upright models).
- When any access door is opened, the interlock switch installed there turns off all power to the game.
- Check each interlock switch for proper operation.

After checking the line voltage in your area and determining that the input wires to the main power supply transformer of your game are connected properly - or - after obtaining a solution to your over or under voltage problem from your distributor and/or your service man, plug the game into your A.C. wall outlet.

The game ON/OFF switch is located as shown in Figure 1-2. Turn the game on and allow it to warm up a few minutes.

Slowly open each access door to the game (this does not include the coin door on Upright models).

As the door is opened approximately 1" (2.54cm) the power to the game should go off (the T.V. monitor, all the lights, and all sounds will stop).

If this does not happen, check the interlock switch by this door to see if it has broken loose from its mounting or if it is stuck in the "ON" position.

If the switch is found to be bad, turn the game off, unplug it, and replace the interlock switch.

When done, plug the game back into the wall outlet, close the access door, and turn the game back on.

After the game has warmed up, repeat the above interlock switch test.

When the interlock switch is working properly and turns the power to the game off, power may be restored to the game with the access door(s) open. Take hold of the interlock switch plunger and **gently** pull it out to its fully extended position. **THIS IS TO BE USED ONLY FOR SERVICING THE GAME.** See Figure 1-3.

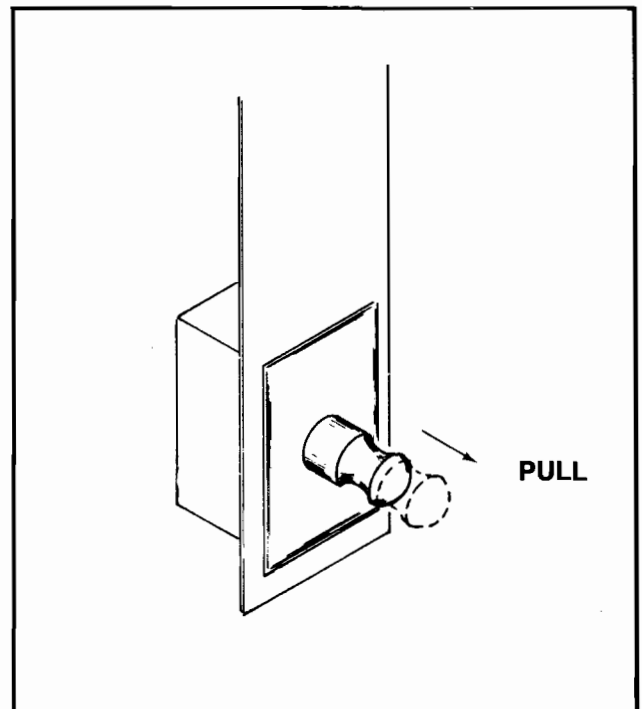

Figure 1-3 Interlock Switch Operation

#### 4. Video Disc.

The video disc provided with your game is recorded on **BOTH** sides. In the event one side should become damaged, it may be flipped over to play the other undamaged side.

Should it be determined at any time that your game will be out of service for an extended period, we **STRONGLY RECOMMEND** that the video disc be removed from the player, inserted in its jacket, and stored in a vertical position to help prevent warping.

#### **GAME VOLUME ADJUSTMENT CONTROL.** See Figure 1-4.

The game volume control pots are located on a bracket just inside the door. There are 2 pots, one for game sounds volume and one for music volume. For adjustment, they may be reached through the coin door.

To make the sounds louder, turn the pots clockwise as you face them (↻).

To make the sounds **less** loud, turn the pots counterclockwise as you face them (↺).

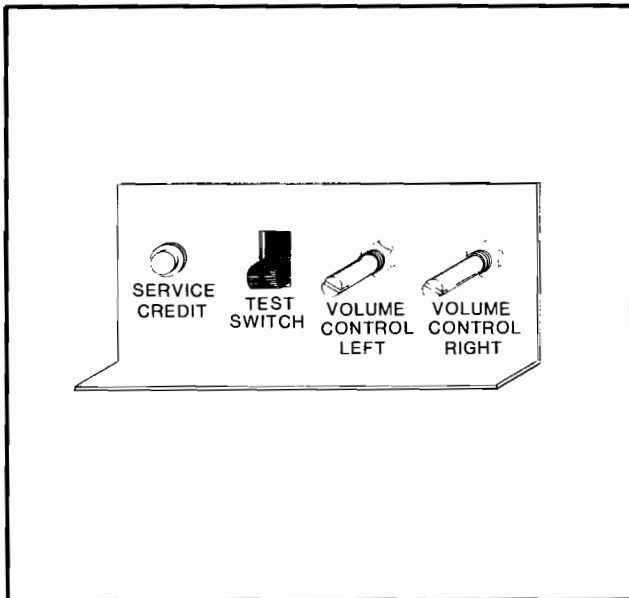

**Figure 1-4 Game Volume Adjustment Controls**

# II GAME OPERATION

## ATTRACT MODE

1. The Attract mode starts:
  - Just after power has been turned on to the game. (Self-Test switch is in the "OFF" position.)
  - After a Self-Test has been completed and there are no more credits left in the games memory.
  - No matter where the game is in the Attract mode sequence, it will immediately go to the Ready-To-Play mode display as soon as a game has been paid for.

## PLAY MODE

1. The Play mode begins when the "GAME START" push button is pressed.
2. The Play mode ends when all of your PLAYERS have been eliminated. When this happens, "GAME OVER" is written across the monitor screen.
3. After completion of game play, the game will either go to the Attract mode (if there are no more credits left in its memory) or into the Ready-To-Play mode (if there are still credits left in its memory).

## READY-TO-PLAY MODE

1. The Ready-To-Play mode starts when enough money has been accepted for a game.
2. The Ready-To-Play mode ends when the "GAME START" push button is pressed.

# III MAINTENANCE AND REPAIR

Your **NEW** game needs certain types of maintenance to keep it in good working order. **CLEAN**, well **MAINTAINED** games **attract players** and **EARN MORE PROFITS**.

## CLEANING

The most important thing you should remember is to clean the outside of the game and money acceptor mechanism(s) on a regular basis.

The outside of the game cabinet plus the metal can be cleaned with any non-abrasive household cleaner. However, the front of the T.V. monitor tube and **both sides** of all other glass and plastic on or in the game **MUST** be cleaned with anti-static cleaner **ONLY**. For cleaning the coin acceptor(s); hot soapy water may be used on the plastic ones and any household cleanser may be used on the metal ones. If you wish, special coin machine cleaners that leave no residue may be purchased from your distributor. For cleaning the bill acceptor mechanism, refer to it's instruction manual (provided with your game under separate cover).

**DO NOT** dry-wipe any of the plastic panels. This is because any dust that was on them can scratch their surfaces. If this has happened, anyone looking through this type of damaged plastic would feel he was looking at the game through a fog. This fogging damage **CAN NOT** be repaired or reversed. The **ONLY** solution is to **replace** the damaged piece of plastic.

## FUSE REPLACEMENT

This game contains several fuses located as shown in Figure 3-1.

### 1. UPRIGHT MODEL:

As viewed from the back, facing the cabinet, with the rear access door(s) removed; the fuses are located on the Power Chassis.

2. Replace fuses **ONLY** with the type and size listed in the Illustrated Parts Breakdown Section of your manual.

See the T.V. Monitor Manual (available on request from your distributor or the monitor manufacturer) and/or the T.V. Troubleshooting Section of your manual for information on these fuses.

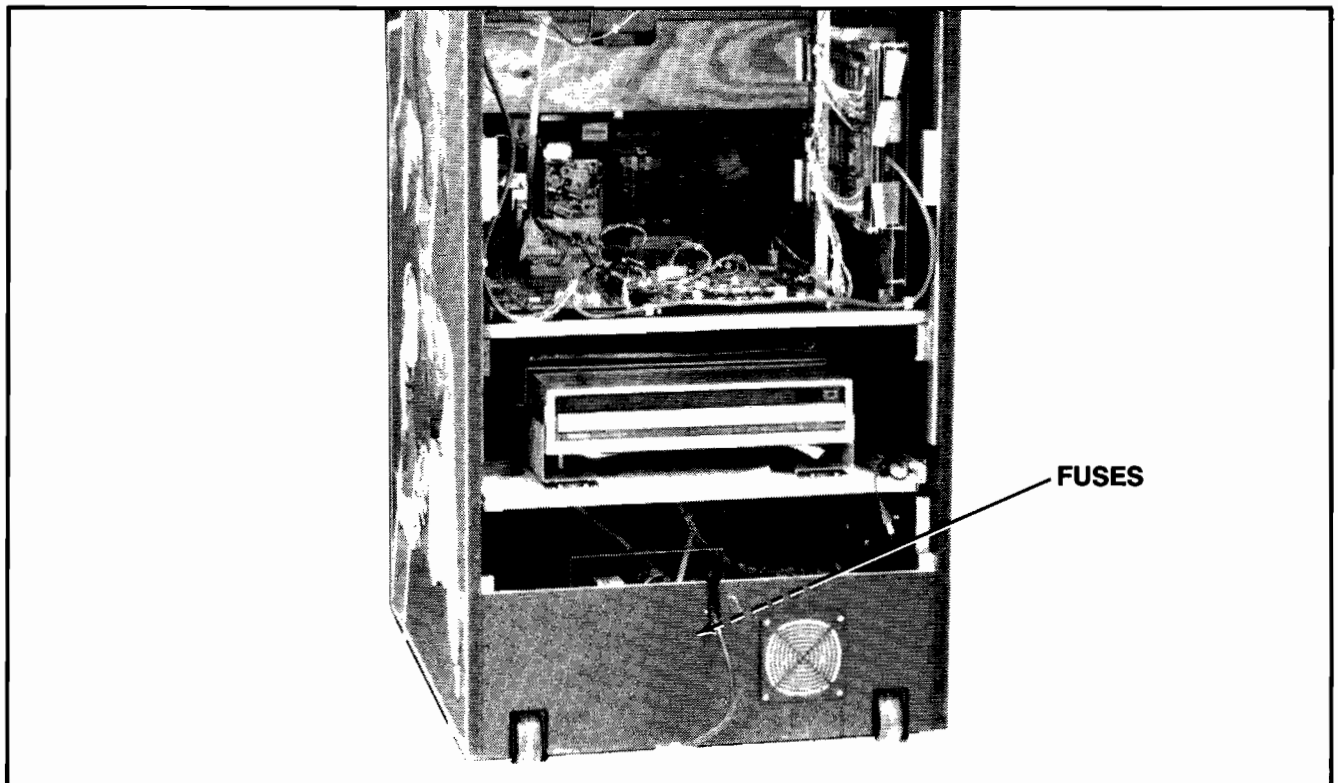

Figure 3-1 Location of Fuses

## OPENING THE CONTROL PANEL

### 1. UPRIGHT MODEL: SEE FIGURE 3-2.

- The control panel is held in place by a nylon retaining strap and three latches, one on the left side, one on the right side, and one in the center of the rear of the cabinet.

They are spring loaded to provide constant positive pressure on their latch plates.

They can be reached through the coin door **AFTER turning power to the game off.**

To release the latches, lift up and toward the front center of the control panel.

Once they are released, unhook them from their latch plates.

- To remove the control panel:

Raise it up and tilt it toward you until you can see the cable and nylon retaining strap behind it.

Cradling the control panel between yourself and the cabinet, disconnect it from its cabling and nylon retaining strap.

The control panel is now free and can be removed.

- To re-install the control panel, reverse this procedure.

## REMOVAL OF THE MAIN-DISPLAY-GLASS AND/OR THE DIFFUSER AND/OR THE T.V. BEZEL:

### 1. UPRIGHT MODEL:

**NOTE:** In order to do this, the control panel **MUST** be removed first. See the "Upright Model" procedure.

- Turn the power to the game off and remove the control panel.

- By putting your finger in the hole in the middle of the main-display-glass/diffuser support, you can lift them **BOTH** up slightly and pull them toward you about an inch. Now let them down just far enough so you can get hold of their top edges with your other hand and lift them **BOTH** out of the game. See Figure 3-3.

- To remove the T.V. bezel, loosen and remove the screws that secure it in place. The T.V. bezel is now free and can be lifted out of the game cabinet.

- To reinstall the above removed items, reverse this procedure.

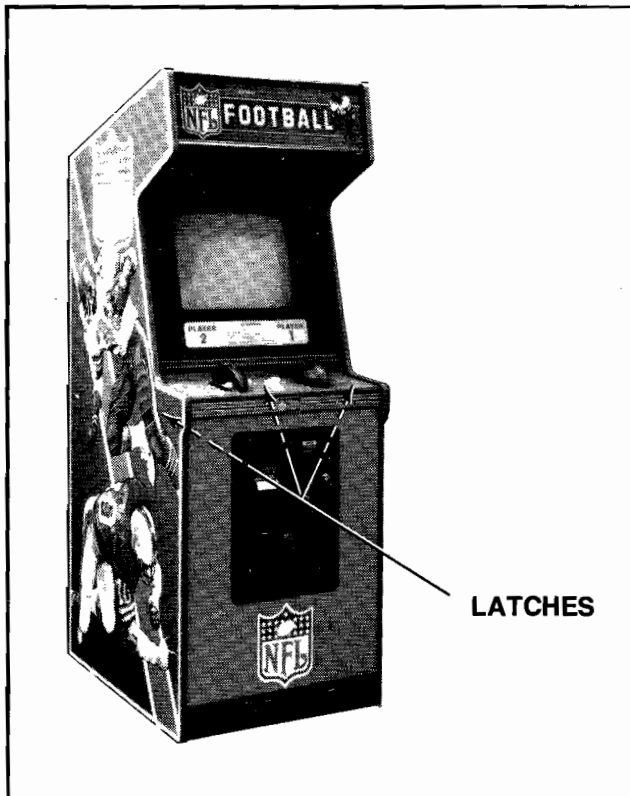

Figure 3-2 Opening the Control Panel

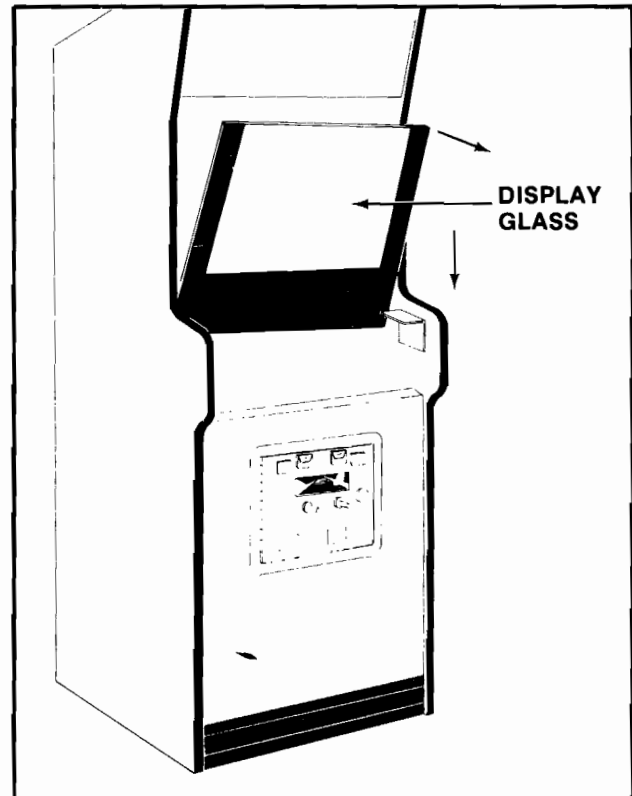

Figure 3-3 Removing the Main-Display-Glass & T.V. Bezel

## T.V. MONITOR REPLACEMENT:

**WARNING:** High voltages may exist in any television unit, even with the power disconnected. Use **EXTREME CAUTION** and do not touch electrical parts or the T.V. yoke area with your hands or with metal objects held in your hands!

In addition, **BE SURE TO USE HEAVY GLOVES** when handling the monitor. You could cut your hands on the metal T.V. chassis without such protection.

**DANGER:** The T.V. monitor **DOES NOT** contain an isolation transformer on its chassis (it is mounted instead on the floor of the cabinet). When servicing the monitor on a test bench, **YOU MUST ISOLATE THE MONITOR FROM A C VOLT-AGE WITH AN ISOLATION TRANSFORMER.**

### 1. Upright Model. See Figure 3-4.

- Turn power off to the game.
- Open the rear access door.
- Completely disconnect the T.V. monitor from all its cabling. **DON'T FORGET THE CHASSIS GROUND WIRE.**
- Before removing the T.V. monitor, the main-display-glass and T.V. bezel must be removed. See above "Upright Model" procedure.
- With the removal of only four bolts, the T.V. monitor will be loose.
- The monitor chassis rests on top of a monitor mounting shelf inside the cabinet. The moni-

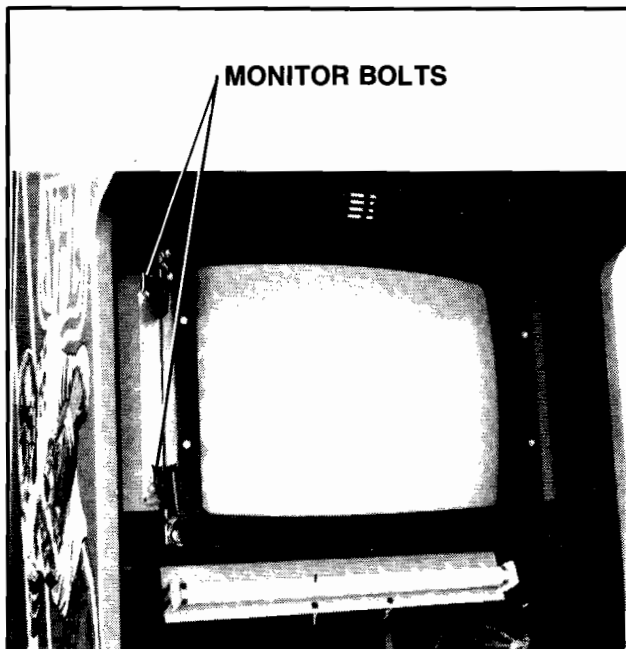

Figure 3-4 Removing the Monitor

tor is removed by sliding it out the front of the cabinet. See Figure 3-4.

- To reinstall the T.V. monitor, reverse this procedure.

## PRINTED CIRCUIT BOARD (P.C.B.) REPLACEMENT:

### 1. UPRIGHT MODEL. See Figure 3-5.

- Turn the power to the game off.
- Unlock and open the rear access door(s).
- Disconnect all cabling from the P.C. board(s) you wish to remove.
- Remove the small P.C.B. clamping devices and slide the P.C.B.(s) from their mountings.
- To separate the large P.C.B. assembly, remove the screws which secure the P.C.B.'s to their support posts and fold them over to the side.
- To reinstall the above P.C.B.(s), reverse this procedure.

**NOTE:** P.C.B.'s are all keyed and will **ONLY** fit into their connectors one way without forcing them. The plugs on the cable harness which connect it to the P.C.B.'s are also keyed and will **ONLY** go onto their connectors one way with out forcing them.

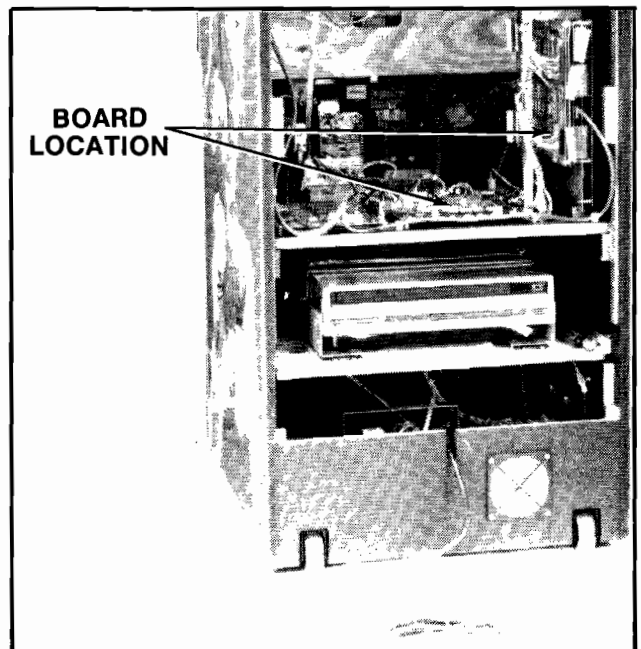

Figure 3-5 Removing the P.C.B.'s

## OPENING THE ATTRACTION PANEL:

### 1. UPRIGHT MODEL:

- Turn the power to the game off.
- Opening the attraction panel:

Remove the screws which secure the top bracket in place. (They are on its top side.) See Figure 3-6.

Remove the top bracket and slide up the attraction panel. This exposes the speakers, and the fluorescent tube assembly.

To reinstall the attraction panel, reverse this procedure.

- The fluorescent light tube may be replaced at this time. BE CAREFUL NOT TO DROP IT.

**WARNING:** If you drop a fluorescent tube and it breaks, IT WILL IMplode! Shattered glass can fly six (6) feet or more from the implosion. Use care when replacing any fluorescent tube.

- Replacing the fluorescent light tube starter. See Figure 3-7.

**Be sure the power to the game has been turned off.**

Grasp the starter (it is on the back of the mounting bracket), give it a quarter turn, and remove it from its socket.

To replace the fluorescent light tube starter, reverse this procedure.

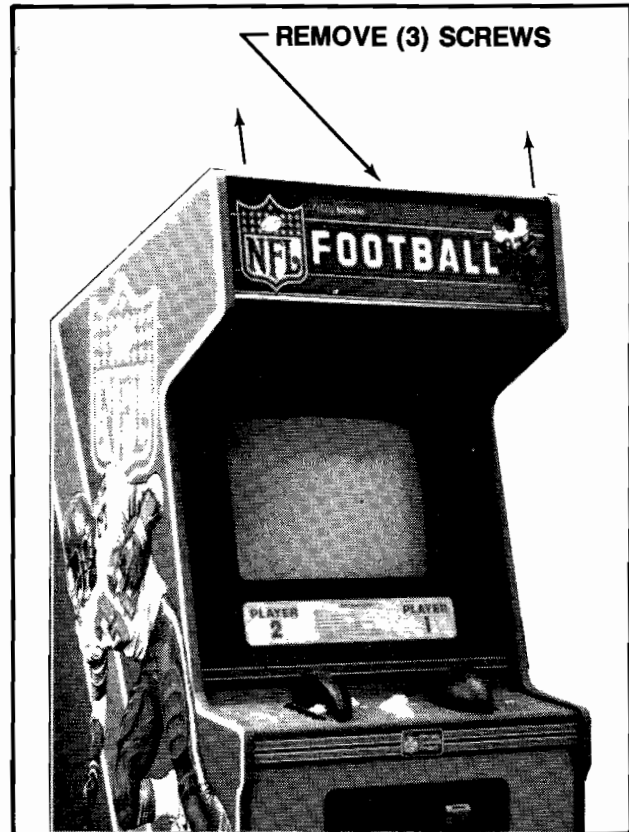

Figure 3-6 Opening the Attraction Panel

- Replacement of the fluorescent tube mounting bracket assembly. See Figure 3-8.

Disconnect it from its power cable.

Remove the screws which secure it in place and remove it from the cabinet.

To reinstall the fluorescent tube mounting bracket assembly, reverse this procedure.

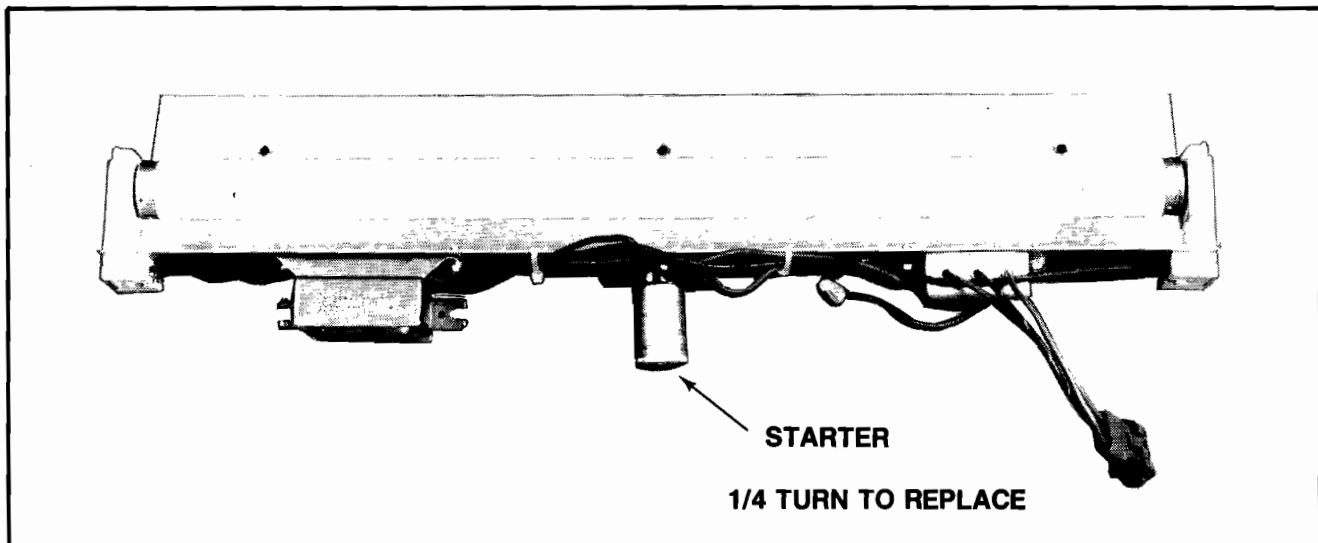
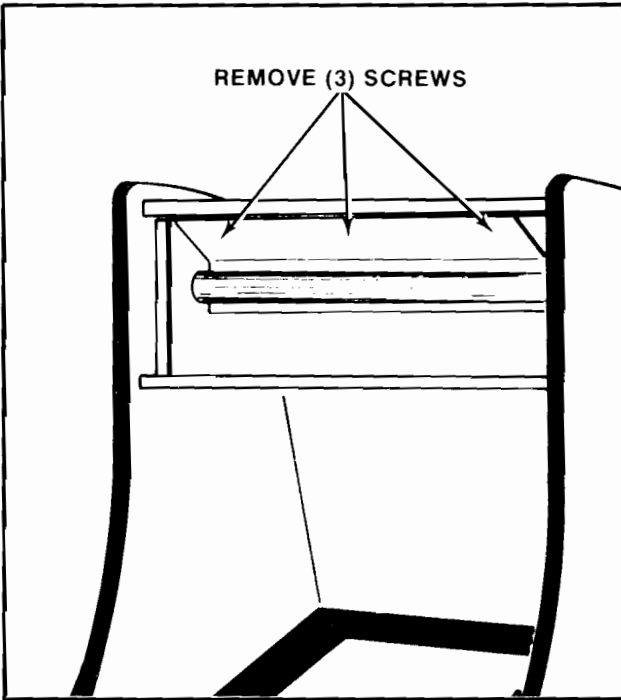

Figure 3-7 Replacing Fluorescent Tube Starter



**Figure 3-8 Replacing Fluorescent Tube Mounting Bracket & Speakers**

Removing the speaker(s):

The attraction panel **MUST** be removed first. This will enable you to reach all the necessary areas where cables **MUST** be disconnected.

Disconnect the speaker(s) from all its cabling. There is one plug at a point near each speaker.

Remove the hardware which secures the speaker(s) to the cabinet and set it aside.

The speaker(s) are now free and can be slid out through the hole in the front of the game where the attraction panel was mounted.

To reinstall the speaker(s), reverse this procedure.

## **IV. Illustrated Parts Breakdown**

NO. 0A34 - N.F.L. UPRIGHT - FRONT

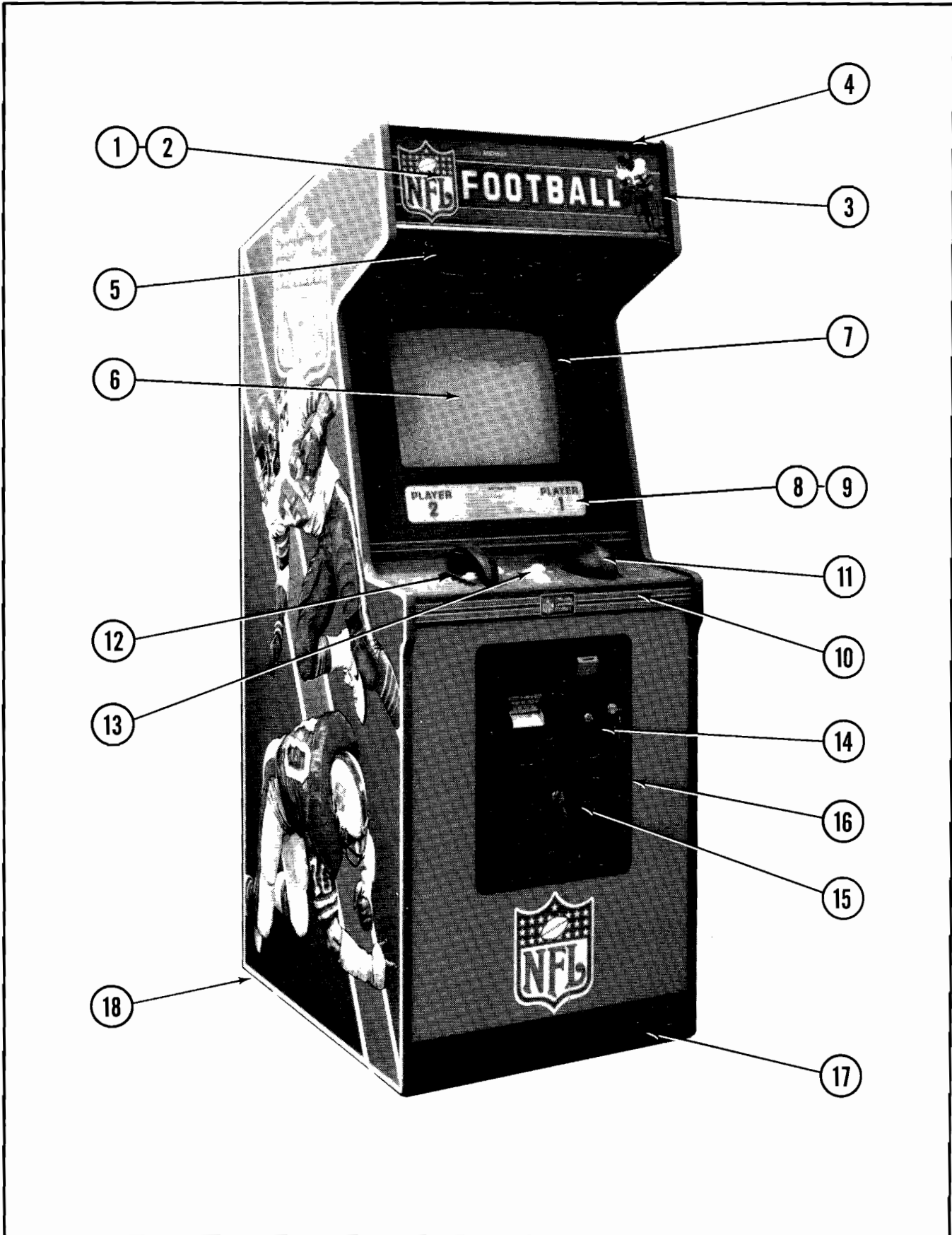

**NO. 0A34 - N.F.L. UPRIGHT - FRONT - PARTS LIST**

ORDER BY PART NUMBER ONLY

ITEM	PART NUMBER	DESCRIPTION	
1	0A34-00901-00XF	HEADER GLASS	
2	A595-00011-0000	FLUORESCENT HEADER LIGHT ASSY.	
3	0537-00903-0054	GLASS CHANNEL - 6-5/8" LG. (2 REQ'D)	
4	0574-00903-0400	HEADER RETAINING BRKT. (2 REQ'D)	
5	0017-00101-0138	#8x5/8 TORX PAN HD. TAMPER PROOF SCREW (10 REQ'D)	
	Q130-00002-0000	6"x9" SPEAKER GRILLE (2 REQ'D)	
	0017-00003-0430	6"x9" SPEAKER - 4 OHM, 10W. (2 REQ'D) OR	
	0017-00003-0461	6"x9" SPEAKER - 4 OHM, 15W. (2 REQ'D)	
	0017-00101-0127	#8-32x1-1/2 CARRIAGE BOLT (8 REQ'D)	
6	0017-00103-0061	#8-32 HEX NUT W/SEMS (8 REQ'D)	
	0017-00003-0466	19" COLOR DUAL SYNC HORIZ. MOUNT MONITOR	
7	0017-00042-0314	19" MONITOR BEZEL - INJECTION MOLDED	
8	0A34-00900-00XF	MAIN VIEWING GLASS	
9	AA34-00013-0000	MAIN VIEWING GLASS FLUOR. LIGHT ASSY.	
10	AA34-00012-0000	CONTROL SHELF PLATE ASSY.	
	0A34-00903-0000	DECORATIVE OVERLAY	
	0595-00106-0100	CONTROL SHELF MTG. BRKT. - RIGHT	
	0595-00106-0200	CONTROL SHELF MTG. BRKT. - LEFT	
	0555-00901-0000	PLASTIC LOCATING PIN (4 REQ'D)	
	0017-00009-0534	BASSICK CLAMP (3 REQ'D)	
	0017-00101-0141	#8x11/16 UNSLOT HEX HD. SCREW (8 REQ'D)	
	0A34-00904-0000	CONTROL SHELF STRAP	
	11	0A34-00902-0000	FOOTBALL SWITCH SHIELD (2 REQ'D)
		0017-00101-0656	#10-32x1/2 SLT. PAN HD. M.S. W/SEMS (6 REQ'D)
12	0017-00032-0092	SMALL LIGHTED PUSH BUTTON SWITCH (10 REQ'D)	
	0929-00905-00XF	SWITCH BEZEL (10 REQ'D)	
	0017-00104-0112	INT. WASHER (10 REQ'D)	
	0017-00103-0089	5/8-24 HEX NUT (10 REQ'D)	
13	0017-00042-0260	PUSH BUTTON ASSY. - WHITE (6 REQ'D)	
	0017-00032-0093	PUSH BUTTON SWITCH W/HOLDER (6 REQ'D)	
	0017-00103-0054	5/8-11 PAL NUT (6 REQ'D)	
14	A982-00014-0006	U.S.A. - COIN DOOR & CABLE ASSY. - \$1.00 & 50¢ (OR)	
	A982-00014-0004	U.S.A. - DOUBLE COIN DOOR & CABLE ASSY - 50¢	
15	A090-00605-0000	CASH BOX DOOR & LOCK ASSY.	
	A090-00606-0000	CASH BOX & PULL ASSY.	
	A090-00189-0000	CASH BOX ENCLOSURE	
	A090-00620-0200	CASH BOX ENCLOSURE ASSY. - (FOR \$1.00 BILL COIN DOOR)	
16	A090-00603-00XF	COIN DOOR FRAME ASSY.	
	0017-00101-0121	#6-32x5/16 PHIL. TRS. HD. SCREW (8 REQ'D)	
17	0935-00906-0700	KICK PLATE - 24-7/8" LG.	
18	0017-00102-0048	3/8-16x2" LEG LEVELERS (4 REQ'D)	
	0017-00103-0026	3/8-16 LEG LEVELER HEX NUTS (4 REQ'D)	

NO. 0A34 - N.F.L. UPRIGHT - REAR ACCESS

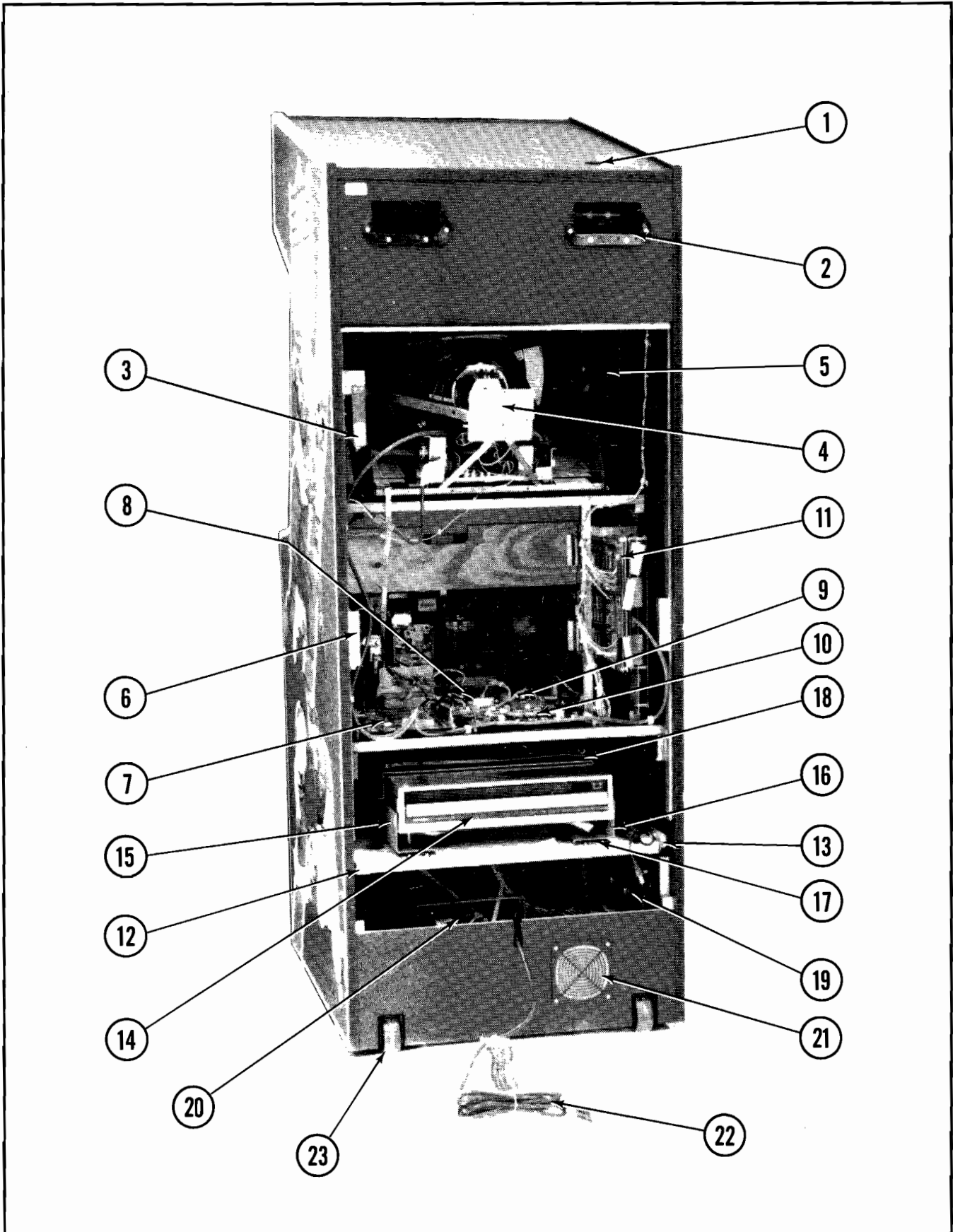

**NO. 0A34 - N.F.L. UPRIGHT - REAR ACCESS - PARTS LIST**

**ORDER BY PART NUMBER ONLY**

<b>ITEM</b>	<b>PART NUMBER</b>	<b>DESCRIPTION</b>
1	A945-00038-0000	ON-OFF SWITCH & PLATE ASSY.
2	0894-00916-0000	PLASTIC PULL & VENT (2 REQ'D)
	0017-00101-0141	#8x11/16 UNSLOT HEX HD. M.S. (8 REQ'D)
3	A088-00016-0000	INTERLOCK SWITCH & SPRING BRKT. ASSY.
	0303-00904-0000	INTERLOCK SWITCH COVER
4	AA34-00011-0000	MONITOR ASSY.
5	0A34-00100-0000	MONITOR RAIL (2 REQ'D)
	0555-00901-0000	PLASTIC LOCATING PIN (4 REQ'D)
	0017-00101-0141	#8x11/16 UNSLOT HEX HD. M.S. (10 REQ'D)
6	0017-00003-0517	N.T.S.C. RGB P.C. BOARD
7	AA34-00024-0000	I.P.U. P.C. BOARD W/SPACER ASSY.
	A084-91695-AA34	I.P.U. P.C. BOARD ASSY.
	0017-00042-0320	SPACER (4 REQ'D)
	0017-00101-0141	#8x11/16 UNSLOT. HEX HD. M.S. (4 REQ'D)
8	AA34-00022-0000	DUAL POWER AMP W/MIXER P.C.B. W/SPACER ASSY.
	A084-91648-A000	DUAL POWER AMP W/MIXER P.C.B. ASSY.
	0017-00042-0320	SPACER (4 REQ'D)
	0017-00101-0141	#8x11/16 UNSLOT. HEX HD. M.S. (4 REQ'D)
9	AA34-00021-0000	AUXILIARY POWER SUPPLY - 5V P.C. W/SPACER ASSY.
	A084-91631-B000	AUXILIARY POWER SUPPLY - 5V P.C.B. ASSY.
	0017-00042-0320	SPACER (4 REQ'D)
	0017-00101-0141	#8x11/16 UNSLOT. HEX HD. M.S. (4 REQ'D)
10	AA34-00023-0000	SQUAWK/TALK P.C. BRD. W/SPACER ASSY.
	A084-91660-AA34	SQUAWK/TALK P.C. BOARD ASSY.
	0017-00042-0320	SPACER (4 REQ'D)
	0017-00101-0141	#8x11/16 UNSLOT. HEX HD. M.S. (4 REQ'D)
11	AA34-00005-0000	CARD RACK W/BOARDS ASSY.
	A084-91657-AA34	PROG. SSI/O W/PANNING P.C. ASSY.
	A639-00060-0000	SHIELD & BARRIER ASSY.
	0017-00101-0134	#6-32x1/4 PHIL. RND. HD. SCREW (4 REQ'D)
	A084-91490-AA34	5 MHZ CPU P.C.B. ASSY.
	A358-00016-0000	SHIELD & SPACER ASSY. - INNER
	A084-91464-AA34	SUPER VIDEO/GENERATOR P.C.B. ASSY.
	A358-00017-0000	SHIELD & SPACER ASSY. - OUTER
	0017-00101-0153	#6-32x1" PHIL. RND. HD. M.S. (8 REQ'D)
12	AA34-00009-0100	BRKT. & WELD NUT ASSY. - RIGHT
13	AA34-00009-0200	BRKT. & WELD NUT ASSY. - LEFT
	0555-00901-0000	PLASTIC LOCATING PIN (4 REQ'D)
	0017-00101-0141	#8x11/16 UNSLOT HEX HD. M.S. (8 REQ'D)
14	0017-00003-0514	R.C.A. VIDEO DISC PLAYER
	0017-00003-0515	VIDEO DISC - N.F.L.
15	AA34-00010-0200	WELD STUD TO SUPPORT BRKT. ASSY. - RIGHT
16	AA34-00010-0200	WELD STUD TO SUPPORT BRKT. ASSY. - LEFT
17	0017-00041-0704	SHOCK MOUNT GROMMET (4 REQ'D)
	0A34-00104-0000	SHOCK MOUNT PLATE (4 REQ'D)
	0017-00101-0141	#8x11/16 UNSLOT HEX HD. M.S. (16 REQ'D)
	0017-00103-0019	1/4-20 LOCK NUT (4 REQ'D)
18	AA34-00019-0000	WELD STUD & CLAMPING BRKT. ASSY.
	0A34-00107-00XF	VIDEO DISC STRAP
	0017-00103-0012	#10-32 WING NUT (2 REQ'D)

**NO. 0A34 - N.F.L. UPRIGHT - REAR ACCESS - PARTS LIST**

ORDER BY PART NUMBER ONLY

ITEM	PART NUMBER	DESCRIPTION
19	AA34-00020-0000 A084-91695-AA34 0017-00042-0320 0017-00101-0141	POWER SUPPLY W/SPACER ASSY. POWER SUPPLY ASSY. SPACER (4 REQ'D) #8x11/16 UNSLOT. HEX HD. M.S. (4 REQ'D)
20	A945-00020-0000	POWER CHASSIS ASSY. - 125VA, 115V.
21	AA30-00020-0000 Q270-00010-0000 0017-00101-0076	MTG. PLATE TO FAN ASSY. FAN GRILLE/FILTER #8-32x3/4 SLT. HEX HD. EXT. WASH. M.S. (4 REQ'D)
22	A945-00019-0000	LINE CORD ASSY. - 115V
23	A961-00007-0000	CASTER ASSEMBLY (2 REQ'D)
<b>ADDITIONAL PARTS LIST</b>		
	0017-00005-0050 0017-00009-0490	BACK DOOR LOCK W/2 KEYS 5-5/8" VENT GRILLE (2 REQ'D)

**HEADER FLOURESCENT FIXTUTRE ASSY.**

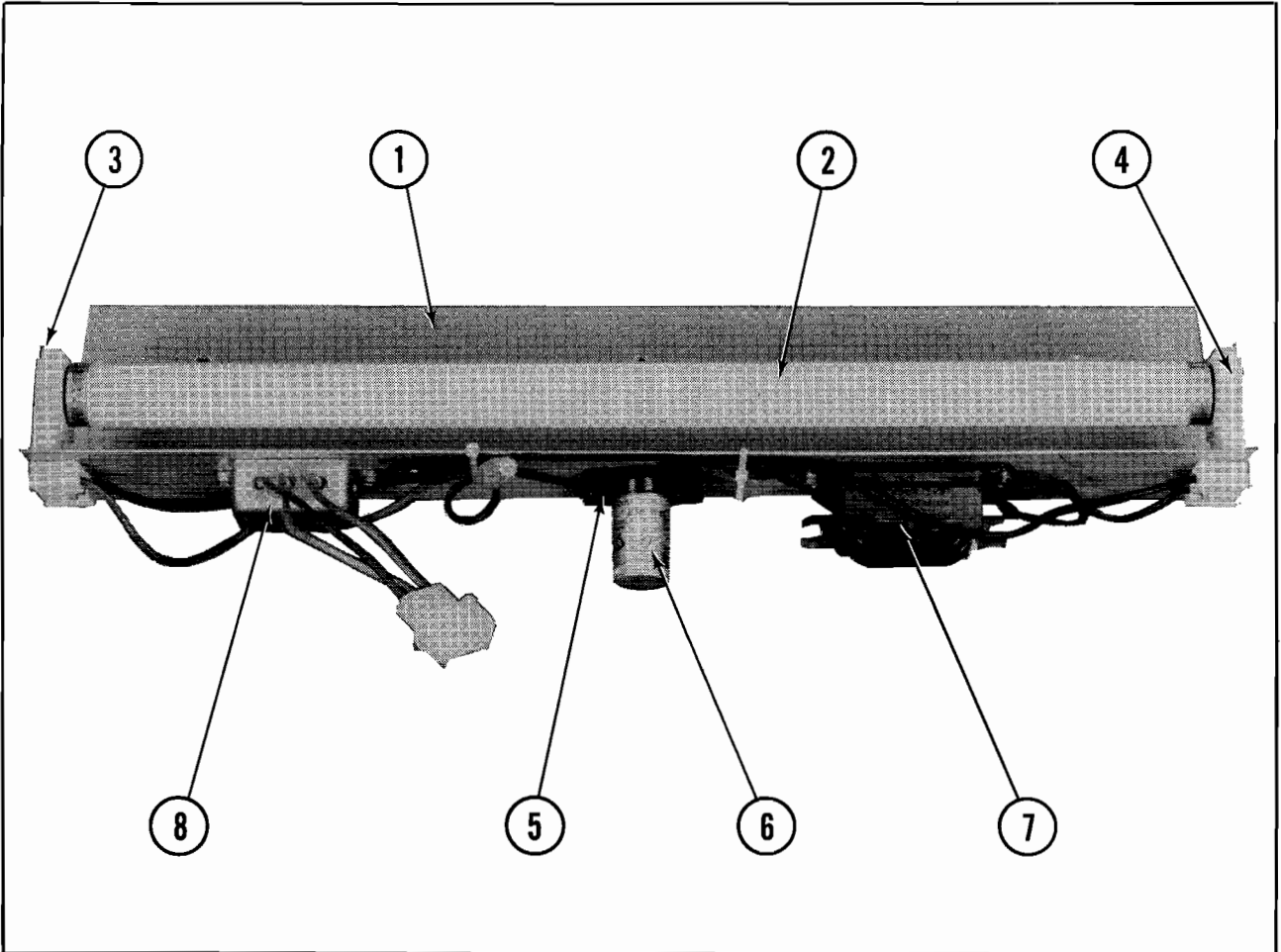

**HEADER FLOURESCENT FIXTUTRE ASSY. - PARTS LIST**

*ORDER BY PART NUMBER ONLY*

ITEM	PART NO.	DESCRIPTION
1	0595-00105-0000	FLUORESCENT BRKT.
2	0017-00003-0043	18" COOL WHITE FLUORESCENT LAMP
3	0017-00003-0445	LAMP LOCKS (2 REQ'D.)
4	0017-00031-0036	FLUORESCENT SOCKET (2 REQ'D.)
5	0017-00003-0412	FLUORESCENT STARTER HOLDER W/LEADS
	0017-00101-0573	#6-32 x 1/2 PHIL. RND. HD. M.S. (4 REQ'D.)
	0017-00104-0009	#6 EXT. WASHER (4 REQ'D.)
6	0017-00003-0019	FLUORESCENT STARTER
7	0017-00003-0026	BALLAST
	0017-00101-0598	#8-32 x 5/16 SLT. HEX HD. SCR. (4 REQ'D.)
8	A961-00042-0000	LINE FILTER ASSY.

— POWER CHASSIS ASSY. — 125VA., 115V.

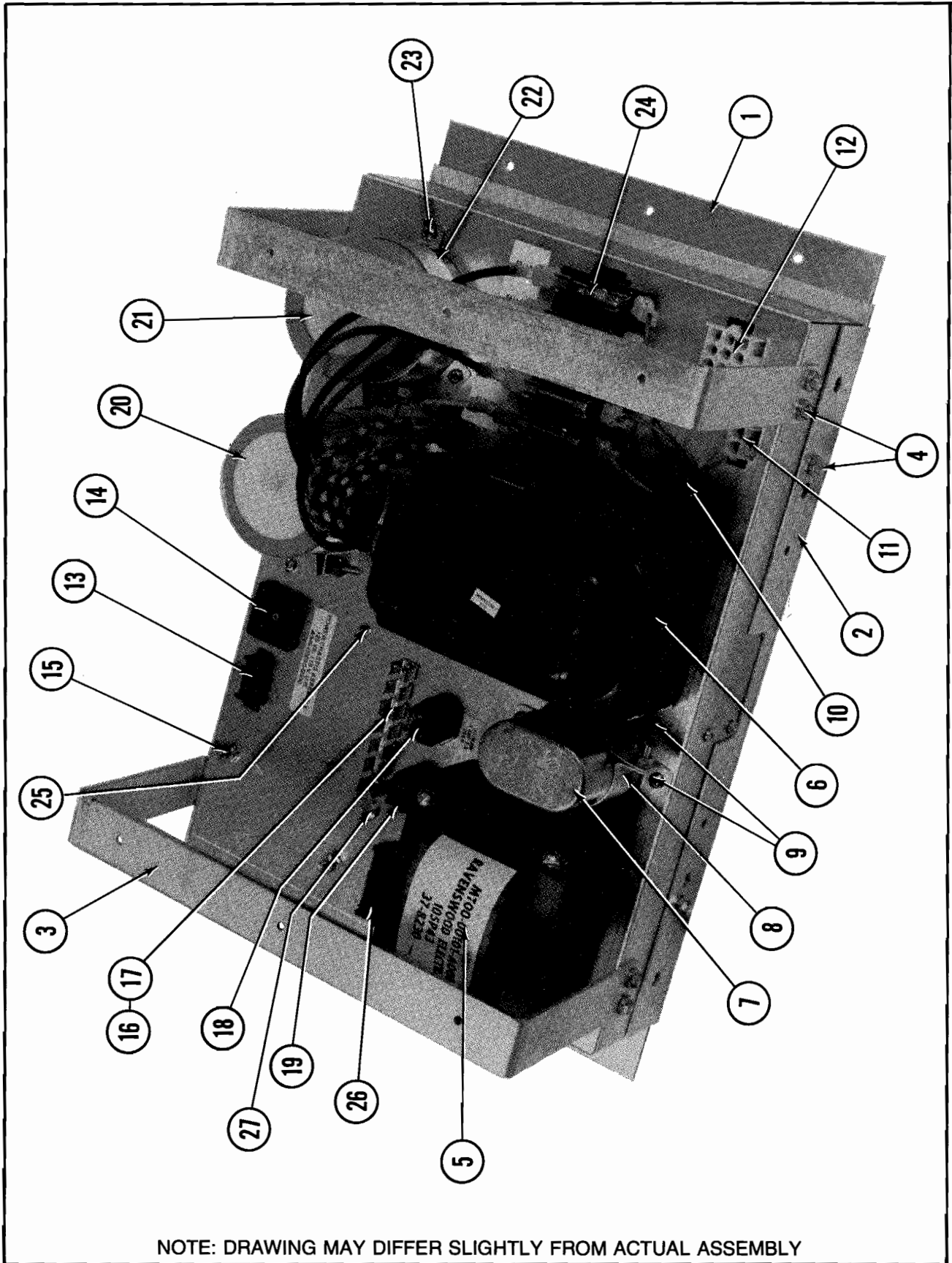

**POWER CHASSIS ASSY.—125VA., 115V.—PARTS LIST**

ORDER BY PART NUMBER ONLY

ITEM	PART NO.	DESCRIPTION
1	A945-00046-00XF	CHASSIS & PARTITION ASSY.
2	A945-00029-0100	MTG. PLATE & BARRIER ASSY.
3	0945-00107-01XF	STRAP (2 REQ'D.)
4	0017-00101-0123	#8 x 1/4 UNSLOT. HEX HD. SCR. (12 REQ'D.)
5	MT00-00101-A000	ISOLATION TRANSFORMER W/O SHIELD ASSY. — 115V., 50/60 HZ.
	0017-00103-0061	#8-32 HEX NUT W/SEMS (4 REQ'D.)
6	MT00-00099-A000	POWER TRANSFORMER ASSY. — 115V., 60 HZ.
	0017-00103-0084	#6-32 HEX NUT W/SEMS (4 REQ'D.)
7	0175-181T4-GXJK	CAPACITOR — 3.5 M.F., 440V.
8	0017-00009-0535	CLAMP
	0017-00101-0565	#6-32 x 7/16 SLT. PAN HD. SCR.
	0017-00103-0084	#6-32 HEX NUT W/SEMS
9	0017-00101-0067	#6 x 3/8 PHIL. PAN HD. SCR. (11 REQ'D.)
10	0945-00902-0000	SNAP BUSHING (3 REQ'D.)
11	0017-00021-0297	2 POSITION CONNECTOR
12	A945-00030-0100	CONNECTOR & CABLE ASSY. #1
13	A945-00030-0200	CONNECTOR & CABLE ASSY. #2
14	A945-00021-0000	CONVENIENCE OUTLET ASSY.
15	0017-00101-0573	#6-32 x 1/2 PHIL. RND. HD. SCR. (2 REQ'D.)
	0017-00103-0084	#6-32 HEX NUT W/SEMS (2 REQ'D.)
	A945-00025-0000	FILTER ASSEMBLY — 125V. — UNDER CHASSIS (NOT SEEN)
16	0017-00021-0510	TERMINAL STRIP
17	0017-00101-0140	#4-40 x 5/16 PHIL. PAN HD. SCR. (2 REQ'D.)
18	0017-00003-0263	SLO-BLO FUSE — 4A., 250V.
19	0017-00003-0005	FUSE — 2A., 250V.
	0017-00003-0444	QUICK CONN. FUSEHOLDER (2 REQ'D.) — FOR ABOVE FUSES
20	0945-00816-1902	CAPACITOR — 100,000 M.F.
21	0945-00816-1901	CAPACITOR — 55,000 M.F.
	0017-00104-0107	#10 FLAT WASHER (4 REQ'D.)
	0017-00103-0081	#10-32 HEX NUT W/SEMS (4 REQ'D.)
22	0017-00009-0422	CLAMP (2 REQ'D.)
	0017-00101-0758	#8-32 x 3/4 PHIL. RND. HD. SCREW (2 REQ'D.)
	0017-00103-0061	#8-32 HEX NUT W/SEMS (2 REQ'D.)
23	0017-00101-0067	#6 x 3/8 PHIL. PAN HD. SCR. (6 REQ'D.)
24	0945-00904-0000	5 POSITION FUSE HOLDER
	0017-00003-0263	SLO-BLO FUSE — 4A., 250V.
	0017-00003-0217	SLO-BLO FUSE — 2.5A., 250V. (2 REQ'D.)
	0017-00003-0007	SLO-BLO FUSE — 3A., 250V. (2 REQ'D.)
	0945-00903-0000	FUSE HOLDER BARRIER
	A945-00022-0000	HEATSINK & DIODE ASSY.
	0017-00101-0067	#6 x 3/8 PHIL. PAN HD. SCR. (2 REQ'D.)
25	0017-00101-0780	#6 x 1/2 PHIL. PAN HD. SCREW (2 REQ'D.)
	0017-00021-0629	5 POSITION TERMINAL STRIP — (UNDER CHASSIS)
	A945-00019-0000	LINE CORD ASSY. — 115V. (NOT SHOWN)
26	A945-00030-0500	CONNECTOR & CABLE ASSY.
27	0017-00101-0660	#10-32 x 3/4 PAN HD. SCREW
	0017-00104-0107	#10 FLAT WASHER
	0017-00103-0081	#10-32 HEX NUT W/SEMS

FRONT DOOR ASSEMBLY - U.S.A. 50¢

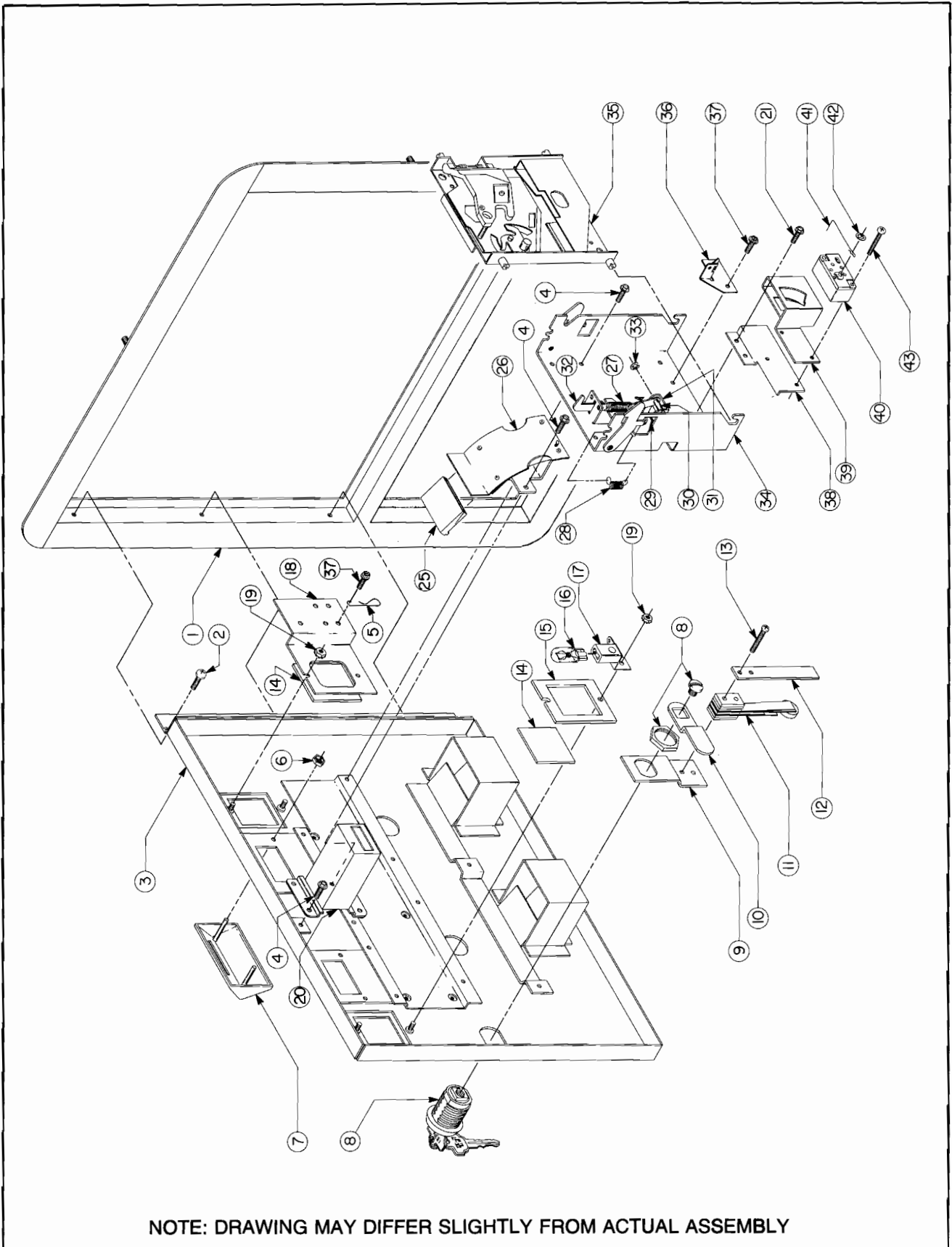

FRONT DOOR ASSEMBLY - U.S.A. 50¢ - PARTS LIST

ORDER BY PART NUMBER ONLY

ITEM	PART NO.	DESCRIPTION
1	A090-00603-00XF	DOUBLE ENTRY COIN DOOR FRAME
2	0017-00101-0121	#6-32x5/16 PHIL. TRS. HD. SCR. (3 REQ'D)
3	A090-00073-02BK	DOUBLE ENTRY COIN DOOR W/DRESS PLATE
4	0017-00101-0123	#8x1/4 UNSLOT HEX HD. SCREW (12 REQ'D)
5	0017-00007-0019	KEY HOOK
6	0017-00103-0059	PUSH NUT (4 REQ'D)
7	0090-00912-0000	COIN ENTRY PLATE - 25¢ (2 REQ'D)
8	A097-00005-0000	DOOR LOCK & KEY W/SCREW & NUT (OR)
	A097-00006-0000	DOOR LOCK & KEY W/SCREW & NUT
9	0090-00128-00XF	DOOR TILT SWITCH BRKT.
10	0017-00005-0041	DOOR CAM
11	A090-00095-0000	DOOR TILT SWITCH
12	0090-00126-03XF	SWITCH BACK-UP PLATE
13	0017-00101-0525	#5-40x9/16" PHIL. HD. M.S. (2 REQ'D)
	A090-00096-0000	DOOR TILT SWITCH & BRKT. ASSY. (ITEMS 9 & 11 THRU 13)
14	0090-00903-4800	PLEXI PLATE 2x25 CENT 1 PLAY (2 REQ'D)
15	0090-00143-00XF	COIN PLEX RETAINER
16	0017-00003-0219	12 VOLT LAMP - G.E. #194 (2 REQ'D)
17	0017-00031-0048	WEDGE SOCKET W/BRKT. (2 REQ'D)
18	A090-00100-0000	BRKT. ASSY.
19	0017-00103-0084	#6-32 HEX NUT W/SEMS (4 REQ'D)
20	A090-00089-0000	COIN METER W/DIODE
21	0017-00101-0124	#6x1/4 UNSLOT HEX HD. SCR. (4 REQ'D)
25	0090-00911-0000	INSULATOR (2 REQ'D)
26	A090-00112-0000	COIN CHUTE & INSULATOR ASSY. (2 REQ'D)
27	0010-00134-0000	SPRING
28	0010-00181-0000	SPRING
29	0017-00007-0083	1/8x1-5/8 ROLL PIN
30	0090-00129-00XF	PIVOT POST
31	0090-00167-00XF	PIVOT LEVER
32	0090-00182-00XF	REJECT LEVER
33	0017-00100-0018	E-RING
	A090-00088-0000	REJECT LEVER ASSY. (2 REQ'D) (ITEMS 30 THRU 33)
34	A090-00117-0000	COIN ACCEPTOR FRAME ASSY. (2 REQ'D)
35	0017-00005-0003	COIN ACCEPTOR W/STRING CUTTER (2 REQ'D) (OR)
	0017-00005-0211	COIN ACCEPTOR W/ANTI STRING DEVICE (2 REQ'D) (OR)
	0017-00005-0214	COIN ACCEPTOR W/STRING CUTTER (2 REQ'D)
36	A090-00064-0000	ANTI-PENNY DEVICE
37	0017-00101-0099	#6x1/4 SLT. HEX HD. M.S. (2 REQ'D)
38	0090-00162-00XF	COIN SWITCH MTG. BRKT.
39	0017-00005-0203	COIN SWITCH CHUTE
40	0017-00005-0195	COIN SWITCH
41	0010-00599-0000	COIN SWITCH WIRE
42	0017-00007-0015	PUSH-ON RING
	A090-00059-0400	COIN SWITCH & WIRE ASSY. (ITEMS 40 THRU 42)
43	0017-00101-0147	#4-40x3/4 PHIL. PAN HD. M.S. (2 REQ'D)
	A090-00077-0000	COIN GUIDE & SWITCH ASSY. (ITEMS 38 THRU 43)

**NFL  
OPTION SWITCH SETTINGS**

**SWITCH NO. 1 - AT B 3 - LOCATED ON SOUND I/O P.C. BOARD**

<b>GAME PLAY:</b>	<b>SW#1</b>	<b>SW#2</b>	<b>SW#3</b>	<b>SW#4</b>	<b>SW#5</b>	<b>SW#6</b>	<b>SW#7</b>	<b>SW#8</b>	<b>SW#9</b>	<b>SW#10</b>
**2 MINUTE GAME	ON	ON				NOT USED	NOT USED	NOT USED	NOT USED	
3 MINUTE GAME	OFF	ON								
4 MINUTE GAME	ON	OFF								
5 MINUTE GAME	OFF	OFF								
**50¢ GAME			ON							
25¢ GAME			OFF							
ATTRACTION SOUNDS OFF				ON						
**ATTRACTION SOUNDS ON				OFF						
**DISPLAY (TIME) OFF					ON					
DISPLAY (TIME) ON					OFF					
FREEZE VIDEO										ON
**NORMAL OPERATION										OFF

**SWITCH NO. 3 - AT D 14 - LOCATED ON SOUND I/O P.C. BOARD IS NOT USED**

\*\*FACTORY RECOMMENDED SETTINGS.

PART NO. MO51-00A34-A007

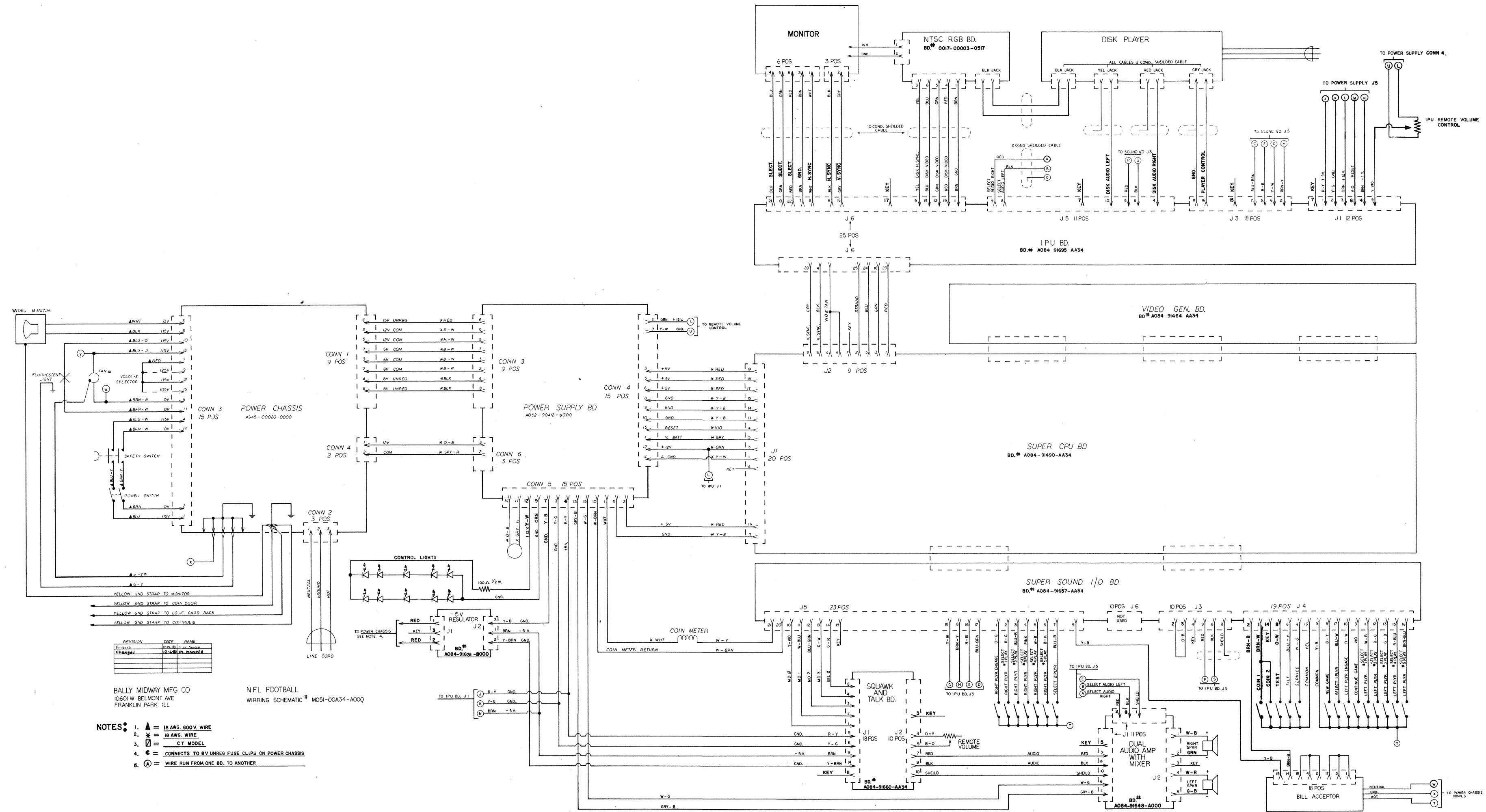

REVISION	DATE	NAME
1	12-15-83	W. M. MANN
2	12-15-83	W. M. MANN
3	12-15-83	W. M. MANN
4	12-15-83	W. M. MANN
5	12-15-83	W. M. MANN

BALLY MIDWAY MFG CO  
10601 W. BELMONT AVE  
FRANKLIN PARK, ILL.

NFL FOOTBALL  
WIRING SCHEMATIC # M051-00A34-A000

- NOTES:
- ▲ = 18 AWG. 600V. WIRE
  - \* = 18 AWG. WIRE
  - = C.T. MODEL
  - ⊕ = CONNECTS TO B.V. UNREG. FUSE CLIPS ON POWER CHASSIS
  - ⊙ = WIRE RUN FROM ONE BD. TO ANOTHER

DESIGNATION LIST

DESIGNATION NO.	DESCRIPTION	DESIGNATION NO.	DESCRIPTION
C1-C14	.01 MF	RP5	1K OHM SIP
C16-C23	.01 MF		
C25,C26	.01 MF	CR1-CR4	1N4148
C27	.1 MF		
C28	.1 MF	Q1	2N4403 PNP
C29-C38	.01 MF		
C40	1000 MF	UA1	74LS32
C41-C44	.1 MF	UA2,UA4	EPROM
C45	10 MF TANT	UA10	28 PIN SOCKET
C46	.01 MF		HM6264P-15
C47,C48	.1 MF	UA11-1,2	CA3080E
C49,C50	NOT USED	UA12	LM339
C51	.1 MF	UB1	74LS04
C52	.022 MF	UB2	74LS161
C53-C64	.01 MF	UB4,UB5	74LS138
C65	33 PF	UB6	74LS00
C66	.01 MF	UB7	74LS74
C67	47 PF 50V	UB8	74LS273
C68	.01 MF	UB9	MC14020B
		UB10	7407
		UB11	MC14572UB
R1-R3	2.7K OHM	UB12	MC4001B
R4	47 OHM	UC5	MC14572UB
R5	1K OHM	UC7	MC1488
R6-R9	2.7K OHM	UC11	MC14016B
R10,R11	100K OHM	UC12	MC14016B
R12	30K OHM	UD2	40 PIN SOCKET
R13,R14	680 OHM		Z80B PIO
R15,R16	4.7 OHM	UD4	40 PIN SOCKET
R17	20K OHM		Z80B CPU
R18	75K OHM	UD5	7406 SN
R19	91K OHM	UD6	40 PIN SOCKET
R20	75K OHM		Z80B SIO
R21	91K OHM	UD7	MC1489
R22,R23	100 OHM 1/2W	UD8	28 PIN SOCKET
R24,R25	100 OHM		Z80B CTC
R26	1.1K OHM	UC12,UD11,UD12	MC14066
R27	62K OHM		
R28,R29	1K OHM	L1-L7	FERRITE BEAD
R30,R31	12K OHM		
R32	56K OHM	Y1	7.3728 MHZ XTAL
R33	27K OHM		
R34	10K OHM	J1	10 PIN KK156
R35	2.2K OHM		STR CONN
R36	4.7K OHM	J3	18 PIN KK100
R37,R38	10K OHM		STR CONN
R39,R40	6.2K OHM	J5	11 PIN KK100
R41	22 OHM		STR CONN
R42	220 OHM	J6	25 PIN KK100
R43	1.2K OHM		STR CONN
R44	82 OHM		TEST POINTS
R46-R49	4.7K OHM		
R51-R53	100 OHM	+5V,-5V,+12, GND TEST CLIPS	

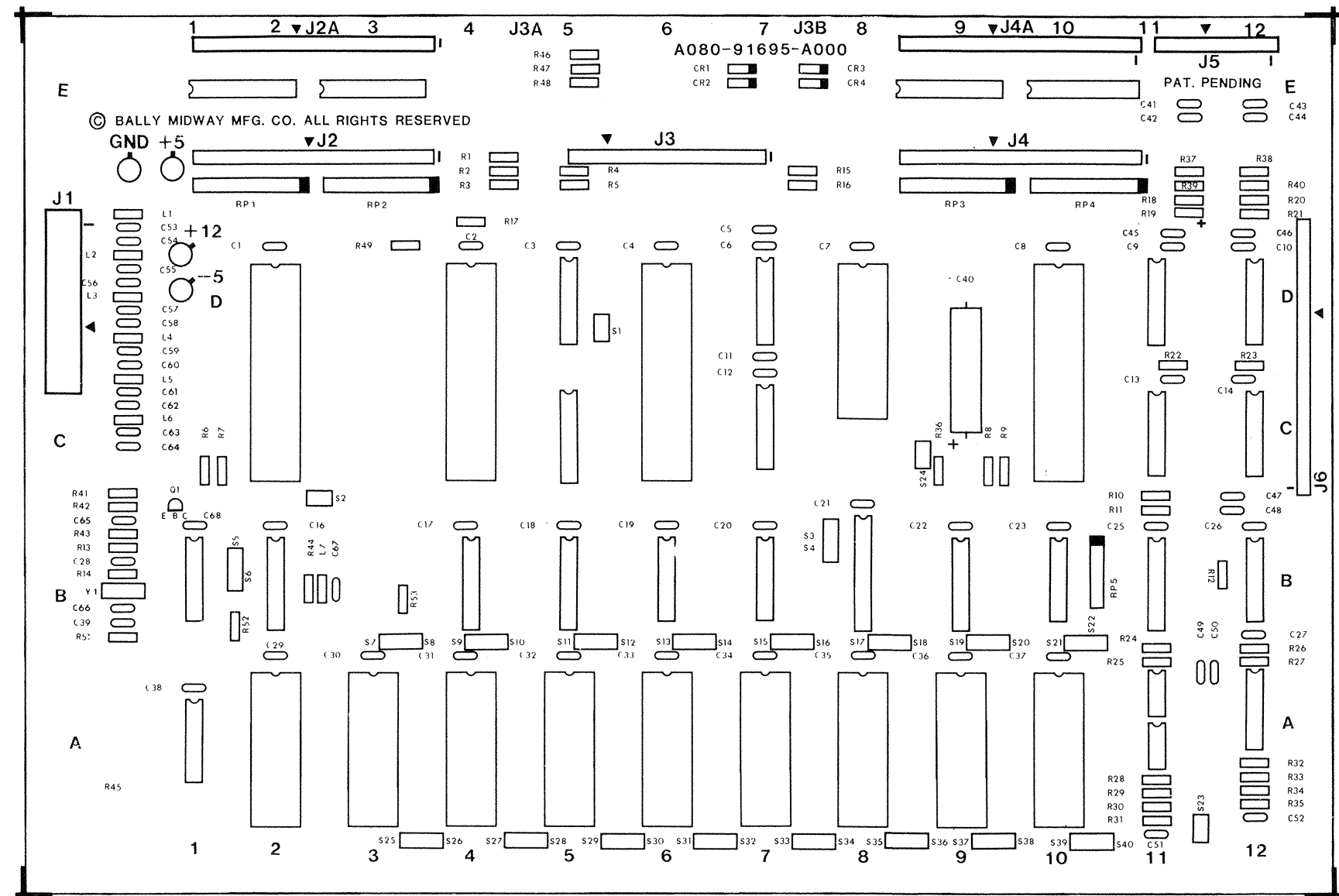

CROSS REFERENCE LIST

DESCRIPTION	QTY	DESIGNATION NO.	PART NOS.	DESCRIPTION	QTY	DESIGNATION NO.	PART NOS.
33 PF AX CER	1	C65	0A34-00800-0004	CA3080E	2	UA11-1,UA11-2	
47 PF 50V	1	C67		LM339	1	UA12	0A34-00803-0023
				MC4001B	1	UB12	0A34-00803-0013
.022 MF AX CER	1	C52	0A34-00800-0006	MC14020B	1	UB9	0A34-00803-0012
.01 MF AX CER	49	C1-C14,C16-C23, C25,C26,C29-C38, C46,C53-C64,C66, C68	0A34-00800-0002	MC14016B	1	UC11	
				MC14066	3	UC12,UD11,UD12	
.1 MF	9	C27,C41-C44,C47, C48,C51,C28	0A34-00800-0008	MC1488	1	UC7	0A34-00803-0014
10 MF AX TANT	1	C45	0A34-00800-0003	MC1489	1	UC5,UB11	0A34-00803-0015
1000 MF AX ELEC	1	C40	0175-291EX-EXBX	MC14572	2	UC7	0A34-00803-0011
				HM6264P-15 RAM	1	UA10	0A34-00803-0017
22 OHM 1/4W CRBN	1	R41		Z80B CPU	1	UD4	0A34-00803-0019
47 OHM 1/4W CRBN	1	R4		Z80B PIO	1	UD2	0A34-00803-0022
82 OHM 1/4W CRBN	1	R44		Z80B SIO	1	UD6	0A34-00803-0021
100 OHM 1/4W CRBN	3	R51-R53	100E-00005-0033	Z80B CTC	1	UD8	0A34-00803-0020
100 OHM 1/2W CRBN	2	R22,R23	100E-00006-0021	28 PIN SOCKET	5	UA2,UA4,UA5,UB8, UA10	110E-00001-0010
220 OHM 1/4W CRBN	1	R42	100E-00005-0041				
560 OHM 1/4W CRBN	2	R24,R25		10 PIN KK156	1	J1	3000-16387-1000
680 OHM 1/4W CRBN	2	R13,R14		ST CONN W/7 OMIT			
1K OHM 1/4W CRBN	3	R5,R28,R29	100E-00005-0061	18 PIN KK100	1	J3	3000-16387-1100
1.1K OHM 1/4W CRBN	1	R26	100E-00005-0062	ST CONN W/15 OMIT			
1.2K OHM 1/4W CRBN	1	R43	100E-00005-0063	11 PIN KK100	1	J5	3000-16387-1800
2.2K OHM 1/4W CRBN	1	R35	100E-00005-0069	ST CONN W/7 OMIT			
2.7K OHM 1/4W CRBN	7	R1-R3,R6-R9	100E-00005-0071	25 PIN KK100	1	J6	3000-16387-2500
3.6K OHM 1/4W CRBN	2	R39,R40		ST CONN W/17 OMIT			
4.7K OHM 1/4W CRBN	7	R15,R16,R36,R46- R49	100E-00005-0079				
				FERRITE BEAD	7	L1-L7	0017-00009-0225
10K OHM 1/4W CRBN	3	R34,R37,R38	100E-00005-0088	7.3728 MHZ CRYSTAL	1	Y1	
12K OHM 1/4W CRBN	2	R30,R31		TEST CLIPS	4		0017-00007-0131
20K OHM 1/4W CRBN	1	R17	100E-00005-0095				
27K OHM 1/4W CRBN	1	R33	100E-00005-0098				
30K OHM 1/4W CRBN	1	R12	100E-00005-0099				
56K OHM 1/4W CRBN	1	R32	100E-00005-0106				
62K OHM 1/4W CRBN	1	R27	100E-00005-0107				
75K OHM 1/4W CRBN	2	R18,R20					
91K OHM 1/4W CRBN	2	R19,R21					
100K OHM 1/4W CRBN	2	R10,R11	100E-00005-0115				
1K OHM 6 PIN SIP	1	RP5	102E-00004-0009				
1N4148	4	CR1-CR4	103E-00002-0005				
2N4403	1	Q1	104E-00002-0006				
74LS00	1	UB6	0A34-00803-0006				
74LS04	1	UB1	0A34-00803-0001				
7406	1	UD5	0A34-00803-0008				
7407	1	UB10	0A34-00803-0009				
74LS32	1	UA1	0A34-00803-0004				
74LS74	1	UB7	0A34-00803-0007				
74LS138	2	UB4,UB5	0A34-00803-0002				
74LS161	1	UB2	0A34-00803-0024				
74LS273	1	UB8	0A34-00803-0003				
EPROM	1	UA2					
EPROM	1	UA4					

\* NOTE: EPROM PART NUMBERS AT BACK OF CATALOG.

PROJECT ENG: J. JARON	HEAT TREAT	SCALE FULL	USED ON NO REQ'D I PER	REVISIONS
DATE: 01/04/84	MAT'L	ASSEMBLY DWG.		
	FINISH	IPU BOARD		
		A084-91695-AA34		
			PART NO	
			MO51 - 00114 - A100	



DESIGNATION LIST

DESIGNATION NO.	DESCRIPTION	DESIGNATION NO.	DESCRIPTION	DESIGNATION NO.	DESCRIPTION
C101-C103	10 MF 25V AX. TANT.	R173-R178	5.6K OHM 1/4W 5% CRBN.	IC14C	74LS367
C104-C127	.1 MF 50V AX. CER.	R179	24K OHM 1/4W 5% CRBN.	IC30	LM3900
C128,C129	.47 PF 50V AX. CER.	R180-R186	4.7K OHM 1/4W 5% CRBN.	IC30	MC14051
C131	10 MF 25V AX. TANT.	R187,R188	24K OHM 1/4W 5% CRBN.	IC60	74LS02
C134-C137	1 MF 20V AX. TANT.	R189-R195	4.7K OHM 1/4W 5% CRBN.	IC70-90	MC14016
C138	10 MF 25V AX. TANT.	R196	24K OHM 1/4W 5% CRBN.	IC110	74190
C139	.047 MF 100V MYLAR	R197-R202	5.6K OHM 1/4W 5% CRBN.	IC120	PROM5B2A
C140,C141	.01 MF 50V AX. CER.	R203-R208	33K OHM 1/4W 5% CRBN.	IC130	74166
C142	100 PF 50V AX. CER.	R209-R211	13K OHM 1/4W 5% CRBN.	IC130	74LS244
C143	.1 MF 50V AX. CER.	R212	27K OHM 1/4W 5% CRBN.	IC130	MC14051
C144	33 PF 50V AX. CER.	R213	27K OHM 1/4W 5% CRBN.	IC130	7407
C145-C156	.0022 MF 100V 10% MYLAR	R214-R219	33K OHM 1/4W 5% CRBN.	IC130	MC3403
C157-C159	1 MF 20V AX. TANT.	R220-R222	1 MF 20V AX. TANT.	IC130	74126
C161	330 PF 50V AX. CER.	R223	1K OHM 1/4W 5% CRBN.	IC130	74LS244
C162-C164	1 MF 20V AX. TANT.	R224	27K OHM 1/4W 5% CRBN.	IC130	74LS191
C165	330 PF 50V AX. CER.	R225,R226	4.7K OHM 1/4W 5% CRBN.	IC130	74LS191
C166-C168	10 MF 25V AX. TANT.	R227	1K OHM 1/4W 5% CRBN.	IC130	7474
C172	10 MF 25V AX. TANT.	R228	4.7K OHM 1/4W 5% CRBN.	IC130	74S04
C173	.01 MF 50V AX. CER.	R231	300 OHM 1/4W 5% CRBN.	IC130	
CP1	470 MF 16V AX. ELECT.	R232	4.7K OHM 1/4W 5% CRBN.	IC130	
CP2-CP12	.01 MF 50V AX. CER.	R233	3K OHM 1/4W 5% CRBN.	IC130	
CP13	470 MF 16V AX. ELECT.	R234,R235	4.7K OHM 1/4W 5% CRBN.	IC130	
CP14-CP33	.01 MF 50V AX. CER.	R239	100 OHM 1/4W 5% CRBN.	IC130	
CP34	10 MF 25V AX. TANT.	R301-R306	2.7K OHM 1/4W 5% CRBN.	IC130	
CP35-CP46	.01 MF 50V AX. CER.	R401	1K OHM 1/4W 5% CRBN.	IC130	
CP47	470 MF 16V AX. ELECT.	R402	4.7K OHM 1/4W 5% CRBN.	IC130	
CP48-CP51	.01 MF 50V AX. CER.	R405-R407	4.7K OHM 1/4W 5% CRBN.	IC130	
CP52,CP53	10 MF 25V AX. TANT.	RM1	4.7K OHM 10 PIN S.I.P.	IC130	
CP54	470 MF 16V AX. ELECT.	RM7	4.7K OHM 8 PIN S.I.P.	IC130	
CP201-CP204	10 MF 25V AX. TANT.	RM8	820 OHM 8 PIN S.I.P.	IC130	
R101-R107	4.7K OHM 1/4W 5% CRBN.	RM9	1.8K OHM 10 PIN S.I.P.	IC130	
R108-R131	220 OHM 1/4W 5% CRBN.	RM10	22K OHM 10 PIN S.I.P.	IC130	
R135	33K OHM 1/4W 5% CRBN.	RM14	4.7K OHM 10 PIN S.I.P.	IC130	
R138,R141	180K OHM 1/4W 5% CRBN.	D101-D103	1N4148	IC130	
R142,R143	100K OHM 1/4W 5% CRBN.	D105-D107	1N4148	IC130	
R144,R145	620K OHM 1/4W 5% CRBN.	Q101-Q103	11P110	IC130	
R146	10K OHM 1/4W 5% CRBN.	Q104	2N4403	IC130	
R147,R148	100K OHM 1/4W 5% CRBN.	IC1A	7406	IC130	
R149,R150	620K OHM 1/4W 5% CRBN.	IC3A,4A	74LS273	IC130	
R151	10K OHM 1/4W 5% CRBN.	IC5A	74LS374	IC130	
R152	1MEG. OHM 1/4W 5% CRBN.	IC6A	1K X 8 RAM	IC130	
R153	1K OHM 1/4W 5% CRBN.	IC7A	ROM/EPROM 0	IC130	
R154	1MEG. OHM 1/4W 5% CRBN.	IC8A	ROM/EPROM 1	IC130	
R155,R156	10K OHM 1/4W 5% CRBN.	IC9A	ROM/EPROM 2	IC130	
R157,R158	1.2K OHM 1/4W 5% CRBN.	IC10A	ROM/EPROM 3	IC130	
R160,R161	330 OHM 1/4W 5% CRBN.	IC11A	74LS245	IC130	
R162	220 OHM 1/4W 5% CRBN.	IC12A	2-80 CPU	IC130	
R163	1.2K OHM 1/4W 5% CRBN.	IC13A	74LS08	IC130	
R164	22 OHM 1/4W 5% CRBN.	IC2B,4B	74LS244	IC130	
R165,R166	4.7K OHM 1/4W 5% CRBN.	IC7B,8B	74LS138	IC130	

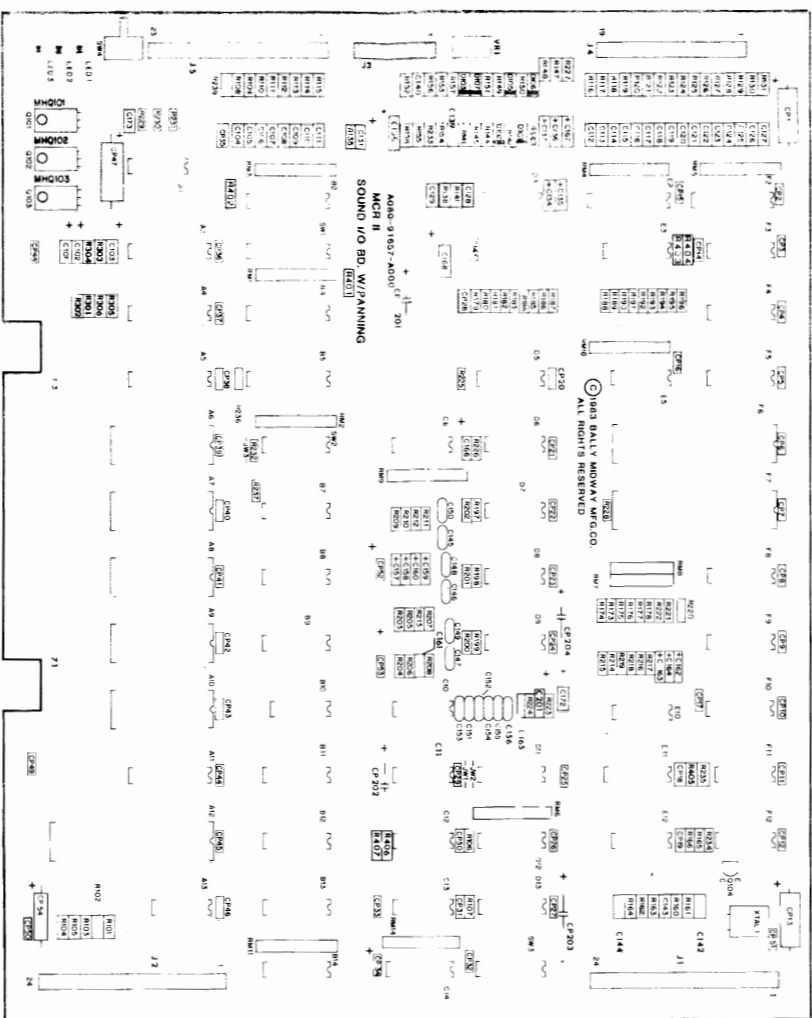

DESCRIPTION	QTY	DESIGNATION NO.	PART NOS.	DESCRIPTION	QTY	DESIGNATION NO.	PART NOS.
33 PF 50V 5% AX. CER.	1	C144	0986-00800-0300	2N4403	1	Q104	0986-00802-0500
47 PF 50V AX. CER.	2	C128,C129	0986-00800-2800	11P110	3	Q101-Q103	0986-00802-0400
100 PF 50V 5% AX. CER.	1	C142	0986-00800-1000	74LS02	1	IC 60	0986-00803-7400
150 PF 50V AX. CER.	2	C161,C165	0986-00800-1300	74LS04	1	IC 11C	0986-00803-6900
.0022 MF 100V 10% MYLAR	12	C145-C156	0986-00800-1200	74LS04	1	IC 12F	0986-00803-6600
.01 MF 50V AX. CER.	1	C139	0986-00800-2600	7406	1	IC 1A	0986-00803-7600
CP2-CP12,CP14-CP33,CP35-CP46,CP48-CP51,C140,C141,C173	25	C104-C127,C143	0986-00800-1100	7407	2	IC 5E,6C	0986-00803-5900
1 MF 20V AX. CER.	10	C134-C137,C157-C159,C162-C164	0986-00800-1400	74LS08	1	IC 13A	0986-00803-7300
10 MF 25V AX. TANT.	16	C166-C168	0986-00800-0700	74190	1	IC 13C	0986-00803-7200
470 MF 16V AX. ELECT.	4	CP1,CP13,CP47,CP54	0986-00800-2700	74LS32	1	IC 10B	0986-00803-6100
22 OHM 1/4W 5% CRBN.	1	R164	0062-06303-1XXX	7474	1	IC 11F	0986-00803-6700
100 OHM 1/4W 5% CRBN.	1	R239	0062-11003-1XXX	74126	1	IC 12E	0986-00803-6800
220 OHM 1/4W 5% CRBN.	25	R108-R131,R162	0062-13303-1XXX	74LS138	4	IC 7B,8B,12B,13B	0986-00803-6500
300 OHM 1/4W 5% CRBN.	1	R231	0062-14103-1XXX	74161	1	IC 11E	0986-00803-5100
330 OHM 1/4W 5% CRBN.	2	R160,R161	0062-14403-1XXX	74166	1	IC 13D	0986-00803-5300
1K OHM 1/4W 5% CRBN.	3	R153,R227,R401	0062-17903-1XXX	74LS174	1	IC 14B	0986-00803-7500
1.2K OHM 1/4W 5% CRBN.	3	R157,R158,R163	0062-18303-1XXX	74LS070	2	IC 11D	0986-00803-9400
2.7K OHM 1/4W 5% CRBN.	6	R301-R306	0062-19903-1XXX	74LS191	6	IC 3F-5F,8F-10F	0986-00803-5600
3K OHM 1/4W 5% CRBN.	1	R233	0062-20103-1XXX	74LS245	4	IC 2B,4B,2E,2F	0986-00803-4800
4.7K OHM 1/4W 5% CRBN.	33	R101-R107,R165,R166,R180-R186,R189-R195,R225,R226,R228,R232,R234,R235,R402,R405-R407	0062-21103-1XXX	74LS244	1	IC 11A	0986-00803-6400
5.6K OHM 1/4W 5% CRBN.	12	R173-R178,R197-R202	0062-21503-1XXX	74LS273	2	IC 3A,4A	0986-00803-4700
10K OHM 1/4W 5% CRBN.	4	R202	0062-22703-1XXX	74LS367	1	IC 14C	0986-00803-7000
13K OHM 1/4W 5% CRBN.	6	R146,R151,R155,R156	0062-23303-1XXX	74LS374	1	IC 5A	0986-00803-8500
24K OHM 1/4W 5% CRBN.	4	R209-R211,R220-R222	0062-24503-1XXX	74LS670	2	IC 9B,11B	0986-00803-6300
27K OHM 1/4W 5% CRBN.	2	R196	0062-24703-1XXX	LM3900	1	IC 6F,7F	0986-00803-8500
33K OHM 1/4W 5% CRBN.	13	R135,R203-R208,R214-R219	0062-25103-1XXX	MC3403	2	IC 3D	0986-00803-4900
100K OHM 1/4W 5% CRBN.	4	R142,R143,R147,R148	0062-27503-1XXX	MC14016	3	IC 10C,10E	0986-00803-5000
180K OHM 1/4W 5% CRBN.	2	R138,R141	0062-28703-1XXX	MC14024	1	IC 70-90	0986-00803-6200
620K OHM 1/4W 5% CRBN.	4	R144,R145,R149,R150	0062-31303-1XXX	MC14051	2	IC 12C	0986-00803-7100
1 MEG. OHM 1/4W 5% CRBN.	2	R152,R154	0062-32303-1XXX	PROM5B2-A	1	IC 3E,5D	0986-00803-5400
820 OHM 8 PIN S.I.P.	1	RM8	0986-00805-0800	RAM 1K X 8	1	IC 6A	0986-00803-8200
1.8K OHM 10 PIN S.I.P.	1	RM9	0986-00805-0600	ROM/EPROM 0	1	IC 7A	0986-00803-8000
2.7K OHM 10 PIN S.I.P.	3	RM3-RM5	0986-00805-0500	ROM/EPROM 1	1	IC 8A	EPROM/ROM
4.7K OHM 8 PIN S.I.P.	1	RM7	0986-00805-0400	ROM/EPROM 2	1	IC 9A	EPROM/ROM
4.7K OHM 10 PIN S.I.P.	2	RM1,RM14	0986-00805-0300	ROM/EPROM 3	1	IC 10A	OPTIONS KIT
22K OHM 10 PIN S.I.P.	1	RM10	0986-00805-0700	2-80(3880)	1	IC 12A	0986-00803-5500
1N4148	6	D101-D103,D105-D107	0986-00801-0200	16 PIN IC SOCKET	1	ICS 120	0986-00804-1400

KNOTE: ROM PART NUMBERS AT BACK OF CATALOG.

PROJECT ENG. C. MEDNICK	DATE: 01/04/84	USED ON	NO REQ'D I PER	REVISIONS
DO NOT SCALE	SCALE: FULL	FRANKLIN, PA. U.S.A.		
ASSEMBLY DWG.	SOUND I/O BD. W/PANNING	A084-91657-AA34		
PART NO. M051-00986	- A034			

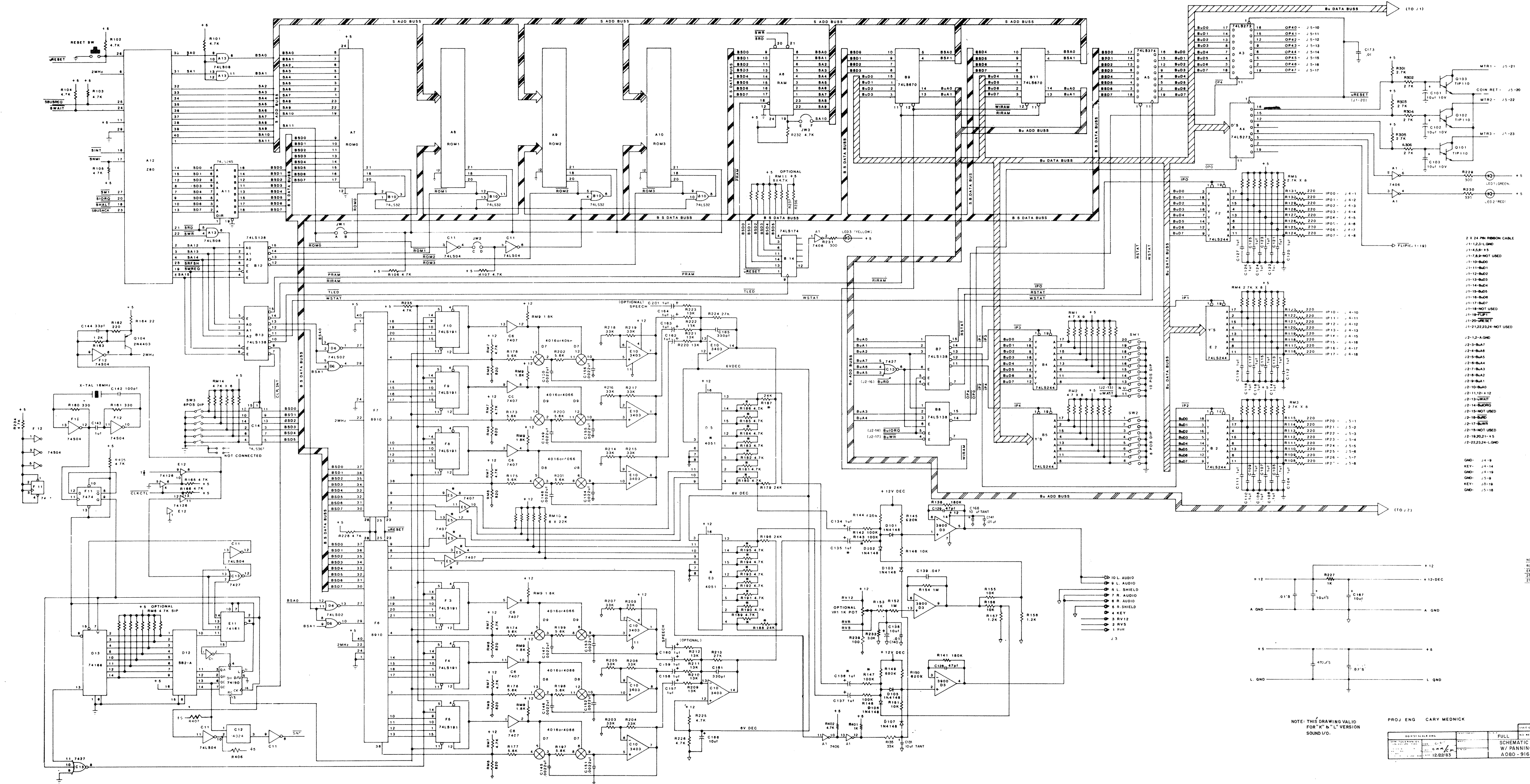

- 72 PIN TEST COMB
- 1-1 GND
  - 2-18
  - 3-1 GND
  - 4-18
  - 5-112
  - 6-1 SA0
  - 7-1 SA1
  - 8-1 SA2
  - 9-1 SA3
  - 10-1 SA4
  - 11-1 SA5
  - 12-1 SA6
  - 13-1 SA7
  - 14-1 SA8
  - 15-1 SA9
  - 16-1 SA10
  - 17-1 SA11
  - 18-1 SA12
  - 19-1 SA13
  - 20-1 SA14
  - 21-1 SA15
  - 22-1 SA16
  - 23-1 SA17
  - 24-1 SA18
  - 25-1 SA19
  - 26-1 SA20
  - 27-1 SA21
  - 28-1 SA22
  - 29-1 SA23
  - 30-1 SA24
  - 31-1 SA25
  - 32-1 SA26
  - 33-1 SA27
  - 34-1 SA28
  - 35-1 SA29
  - 36-1 SA30
  - 37-1 SA31
  - 38-1 SA32
  - 39-1 SA33
  - 40-1 SA34
  - 41-1 SA35
  - 42-1 SA36
  - 43-1 SA37
  - 44-1 SA38
  - 45-1 SA39
  - 46-1 SA40
  - 47-1 SA41
  - 48-1 SA42
  - 49-1 SA43
  - 50-1 SA44
  - 51-1 SA45
  - 52-1 SA46
  - 53-1 SA47
  - 54-1 SA48
  - 55-1 SA49
  - 56-1 SA50
  - 57-1 SA51
  - 58-1 SA52
  - 59-1 SA53
  - 60-1 SA54
  - 61-1 SA55
  - 62-1 SA56
  - 63-1 SA57
  - 64-1 SA58
  - 65-1 SA59
  - 66-1 SA60
  - 67-1 SA61
  - 68-1 SA62
  - 69-1 SA63
  - 70-1 SA64
  - 71-1 SA65
  - 72-1 SA66

NOTE: THIS DRAWING VALID FOR "K" & "L" VERSION SOUND I/O.

PROJ. ENG. CARY MEDNICK

DATE: 12/22/85

REV: 1

SCHEMATIC SOUND I/O

W/ PANNING

A080-91657-A000

MIDWAY MFG. CO.

M051-00986-A035

DESCRIPTION LIST

DESIGNATION NO.	DESCRIPTION	DESIGNATION NO.	DESCRIPTION
C1	10 MF TANT.	R54	82K 1/4W 5%
C2	.01 MF 25/50V CER	R55	10K 1/4W 5%
C3,C4	27 PF 100V AX CER	R56	2K 1/4W 5%
C5-C8	.01 MF 25/50V CER		NOT USED
C9	470 PF 50V AX CER	R57	NOT USED
C10,C11	.01 MF 25/50V CER	R58	1K 1/4W 5%
C12,C13	.1 MF 25V AX CER	R59,R60	1 MEG
C14,C15	390 PF 50V AX CER	R61	100K 1/4W 5%
C16	100 MF TANT.	R62	NOT USED
C17,C18	.01 MF 25/50V CER	R63-R67	10K 1/4W 5%
C19	1 MF 25/50V ELECT	R68	510 OHM 1/4W 5%
C20	470 PF 50V AX CER	R69,R70	NOT USED
C21	68 PF 100V AX CER	R71-R78	10K 1/4W 5%
C22	4.7 MF 25V TANT	R79	7.5K 1/4W 5%
C23	.47 MF 12/16V AX CER	R80	2K 1/4W 5%
C24,C25	1 MF 25/50V ELECT	R81	1K 1/4W 5%
C26,C27	390 PF 50V AX CER	R82	2.4K 1/4W 5%
C28	1 MF 25/50V ELECT	R83	11K 1/4W 5%
C29	.0047 MF AX CER	R84-R87	2.2K 1/4W 5%
C30	NOT USED	R88,R89	220 OHM 1/4W 5%
C31	NOT USED	R90	220K 1/4W 5%
C32	68 PF 100V AX CER	R91-R93	100K 1/4W 5%
C33	.1 MF 25V AX CER		
C34	1 MF 25/50V ELECT	RM1	4.7K 8 PIN SIP
C35	NOT USED		
C36	NOT USED		
C37	NOT USED	CR1	1N4148 DIODE
C38	NOT USED	CR2-CR4	NOT USED
C39	.1 MF 25V AX CER	CR5,CR6	1N4148 DIODE
C40	NOT USED	CR7,CR8	NOT USED
C41	.1 MF 25V AX CER	CR9	NOT USED
C42	1 MF 25/50V ELECT	CR10	1N4148 DIODE
C43	2 MF 25V ELECT	CR11	1N4148 DIODE
C44	NOT USED		
C45,C46	.1 MF 25V AX CER	LED 1	GREEN LED
C47-C50	NOT USED		
C51	10 PF 50V AX	Q1	2N3904 NPN TRANS.
		Q2	NOT USED
R1	4.7K 1/4W 5%	Q3,Q4	2N4403 PNP TRANS.
R2-R5	3.3K 1/4W 5%	Q5,Q6	2N3904 NPN TRANS.
R6	160 OHM 1/4W 5%		
R7	8.2K 1/4W 5%	U1	6802 CPU
R8	3.3K 1/4W 5%	U2-U5	EPROM KIT
R9	130K 1/4W 5%	U6	NOT USED
R10	10K 1/4W 5%	U7	6821 P.I.A.
R11	330K 1/4W 5%	U8	TMS 5200 SPEECH CHIP
R12	1K 1/4W 5%	U9	NOT USED
R13	200K 1/4W 5%	U10	AD 558
R14	1.8K 1/4W 5%	U11	6821 P.I.A.
R15	470K 1/4W 5%	U12	NOT USED
R16	180K 1/4W 5%	U13,U14	LM3900 QUAD OP-AMP
R17,R18	910K 1/4W 5%	U15	74LS14 HEX SCHMIT INV.
R19	1K 1/4W 5%	U16	4049 HEX INV.
R20	820K 1/4W 5%	U17	74LS155 DEC/DMUIT
R21	390K 1/4W 5%		
R22	200K 1/4W 5%	FB1,FB2	FERRITE BEAD
R23,R24	100K 1/4W 5%		
R25,R26	1 MEG.		
R27	1.2 MEG	J1	(17) KK156 AUTO INSERT PINS
R28	82K 1/4W 5%	J2	(9) KK156 AUTO INSERT PINS
R29	10K 1/4W 5%		DELETE 11
R30	2K 1/4W 5%		
R31	9.1K 1/4W 5%	TPI-TPI2	TEST POINTS
R32	1 MEG.		
R33	91K 1/4W 5%	JUMPER	A-G,L,N,P,R-T, JUMPER TIN 22 AWG
R34,R35	10K 1/4W 5%		V-X,Z-BB,EE(5),FF
R36	1K 1/4W 5%		
R37	NOT USED	JUMPER	H,J,K,M,Q,U,Y, ZERO OHM JUMPER
R38	200K 1/4W 5%		
R39,R40	910K 1/4W 5%		
R41	200K 1/4W 5%		
R42	1K 1/4W 5%		
R43	820K 1/4W 5%		
R44	390K 1/4W 5%		
R45	200K 1/4W 5%		
R46	100K 1/4W 5%		
R47	2.7K 1/4W 5%		
R48	2.4K 1/4W 5%		
R49	1 MEG		
R50	NOT USED		
R51	750K 1/4W 5%		
R52	NOT USED		
R53	NOT USED		

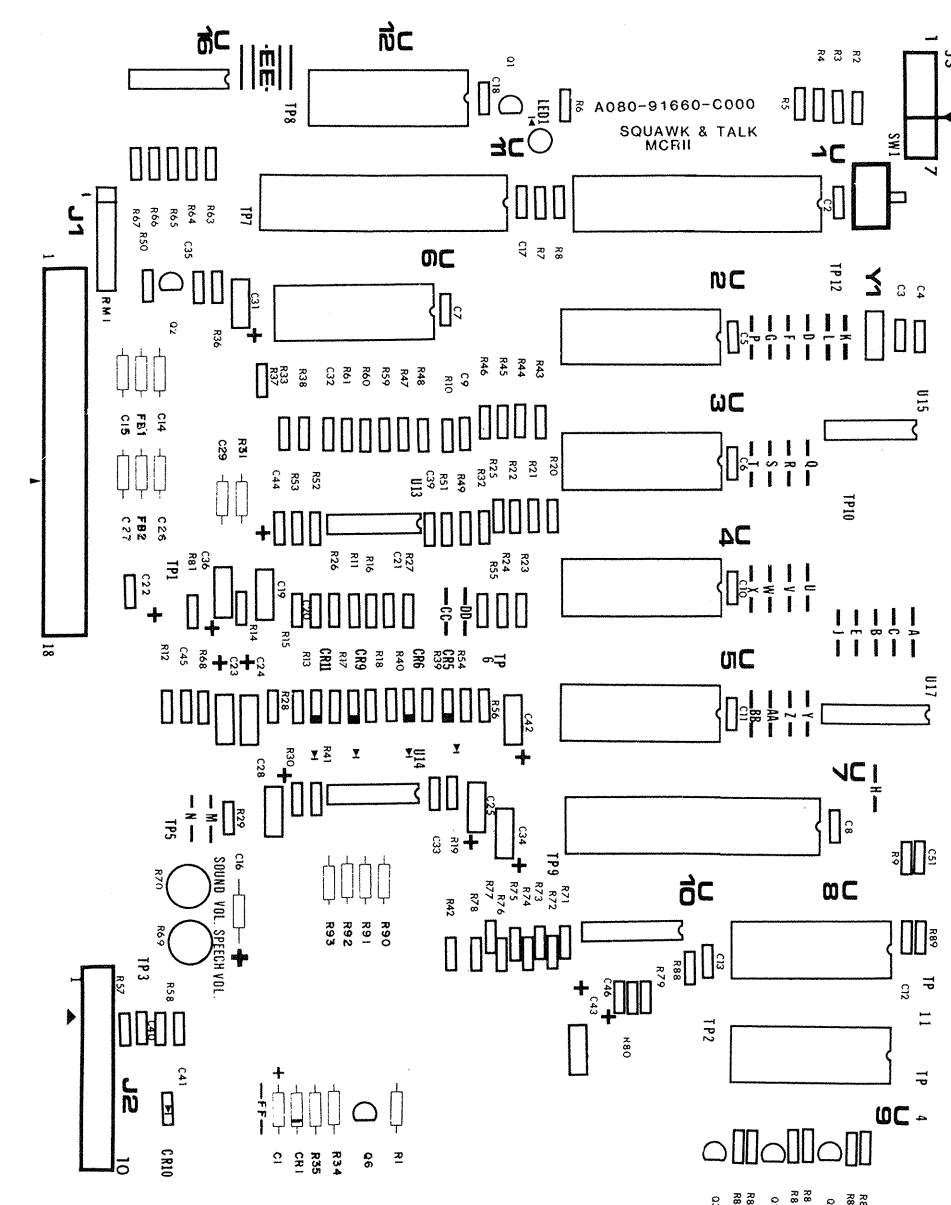

CROSS REFERENCE LIST

DESCRIPTION	QTY	DESIGNATION NO.	PART NOS.	DESCRIPTION	QTY	DESIGNATION NO.	PART NOS.
10 PF 50V AX CER	1	C51	U360-00800-0038	4.7K S.I.P.	1	RM1	0986-00804-5000
27 PF 100V AX CER	2	C3,C4	0360-00800-0009				
68 PF 100V AX CER	2	C21,C32	0360-00800-0010	1N4004 DIODE	1	CR10	0360-00801-0002
390 PF 50V AX CER	4	C14,C15,C26,C27	0360-00800-3000	1N4148 DIODE	5	CR1,CR5,CR6,CR9,CR11	0360-00801-0003
470 PF 50V AX CER	2	C9,C20	0360-00800-0002				
.0047 UF	1	C29	0986-00800-3506				
.01 MF 25/50V CER	9	C2,C5-C8,C10,C11,C17,C18	0360-00800-0005	LED, GREEN	1	LED 1	0360-00804-0015
.1 MF 25V AX CER	7	C12,C13,C33,C39,C41,C45,C46	0360-00800-0014				
.47 MF 12/16V AX CER	1	C23	0360-00800-0017	2N3904 NPN	3	Q1,Q5,Q6	0360-00802-0003
1 MF 25/50V ELECT	6	C19,C24,C25,C28,C34,C42	0360-00800-0018	2N4403 PNP	2	Q3,Q4	0360-00802-0004
2 MF 25V ELECT	1	C43	0360-00800-0019	AD559 D.A.C.	1	U10	0360-00803-0033
4.7 MF 25V TANT	1	C22	0360-00800-0008	LM3900 QUAD OP-AMP	2	U13,U14	0360-00803-0002
10 MF 20/25V TANT	1	C1	0986-00800-3505	4049 HEX INV	1	U16	0360-00803-0011
100 MF 16/20V TANT	1	C16	0986-00800-3504	74LS14 HEX SCHMIT INV.	1	U15	0360-00803-0037
160 OHM 1/4W 5%	1	R6	0062-124B3-1XXX	74LS155 DEC DMULT CHIP	1	U17	0360-00803-0034
220 OHM 1/4W 5%	2	R88,R89	0062-133B3-1XXX	TMS 5200 SPEECH	1	U8	0360-00803-1013
510 OHM 1/4W 5%	1	R68	0062-159B3-1XXX	MC 6802 CPU	1	U1	0986-00803-1012
1K OHM 1/4W 5%	6	R12,R19,R36,R42,R58,R81	0062-179B3-1XXX	MC 6821 P.I.A.	2	U7,U11	0360-00803-0017
1.8K OHM 1/4W 5%	1	R14	0062-191B3-1XXX				
2K OHM 1/4W 5%	3	R30,R56,R80	0062-193B3-1XXX	ROM/EPROM	1	IC U2	* SEE NOTE
2.2K OHM 1/4W 5%	4	R84-R87	0062-195B3-1XXX	ROM/EPROM	1	IC U3	
2.4K OHM 1/4W 5%	2	R48,R82	0062-197B3-1XXX	ROM/EPROM	1	IC U4	
2.7K OHM 1/4W 5%	1	R47	0062-199B3-1XXX	ROM/EPROM	1	IC U5	
3.3K OHM 1/4W 5%	5	R2-R5,R8	0062-203B3-1XXX	FERRITE BEAD	2	FB1,FB2	
4.7K OHM 1/4W 5%	1	R1	0062-211B3-1XXX				
7.5K OHM 1/4W 5%	1	R79	0062-221B3-1XXX	16 PIN DIP SOCKET	1	ICS U10	0360-00804-0026
8.2K OHM 1/4W 5%	1	R7	0062-223B3-1XXX	24 PIN DIP SOCKET	5	ICS U2-U6	0360-00804-0017
9.1K OHM 1/4W 5%	1	R31	0062-225B3-1XXX	28 PIN DIP SOCKET	1	ICS U8	0360-00804-0028
10K OHM 1/4W 5%	18	R10,R29,R34,R35,R55,R63-R67,R71-R78	0062-227B3-1XXX	40 PIN DIP SOCKET	3	ICS U1,U7,U11	0360-00804-0018
11K OHM 1/4W 5%	1	R83	0062-229B3-1XXX	KK156 AUTO	26	J1,J2	0017-00033-0480
82K OHM 1/4W 5%	2	R28,R54	0062-271B3-1XXX	INSERT PINS			
91K OHM 1/4W 5%	1	R35	0062-273B3-1XXX				
100K 1/4W 5%	7	R23,R24,R46,R61,R91-R93	0062-275B3-1XXX	TEST POINTS	12	TPI-TPI2	0017-00007-0131
130K OHM 1/4W 5%	1	R9	0062-282B3-1XXX	JUMPER TIN 22 AWG	25	A-G,L,N,P,R-T, V-X,Z-BB,EE(5),FF	0069-230XX-XBXX
180K OHM 1/4W 5%	1	R16	0062-287B3-1XXX				
200K OHM 1/4W 5%	5	R13,R22,R38,R41,R45	0062-289B3-1XXX	ZERO OHM JUMPER	9	H,J,K,M,Q,U,Y,CC,DD	0360-00804-0023
220K OHM 1/4W 5%	1	R90	0062-291B3-1XXX	3.58 MHZ CRYSTAL	1	Y1	0360-00804-0019
330K OHM 1/4W 5%	1	R11	0062-299B3-1XXX	P.C.B. MOUNT SWITCH	1	SW1	0017-00032-0038
390K OHM 1/4W 5%	2	R21,R44	0062-303B3-1XXX	SQUAWK & TALK P.C.B.	1		A080-91660-C000
470K OHM 1/4W 5%	1	R15	0062-307B3-1XXX				
750K OHM 1/4W 5%	1	R51	0062-317B3-1XXX				
820K OHM 1/4W 5%	2	R20,R43	0062-319B3-1XXX				
910K OHM 1/4W 5%	4	R17,R18,R39,R40	0062-321B3-1XXX				
1 MEG.	6	R25,R26,R32,R49,R59,R60	0062-323B3-1XXX				
1.2 MEG.	1	R27	0062-327B3-1XXX				

\* NOTE: ROM PART NUMBERS AT BACK OF CATALOG.

PROJECT ENG: R. KOHAN	USED ON	REVISIONS	
DO NOT SCALE THIS DRAWING	SCALE FULL	NO. REQ'D 1 PER	
DIM TOLERANCES UNLESS SPECIFIED	MAT'L	SQUAWK & TALK ASSEMBLY DWG A084-91660-AA34	
DATE 01/04/84	FINISH	PART NO. M051-00986-C036	
		Bally / MIDWAY MFG. CO. - FRANKLIN PK. ILL.	

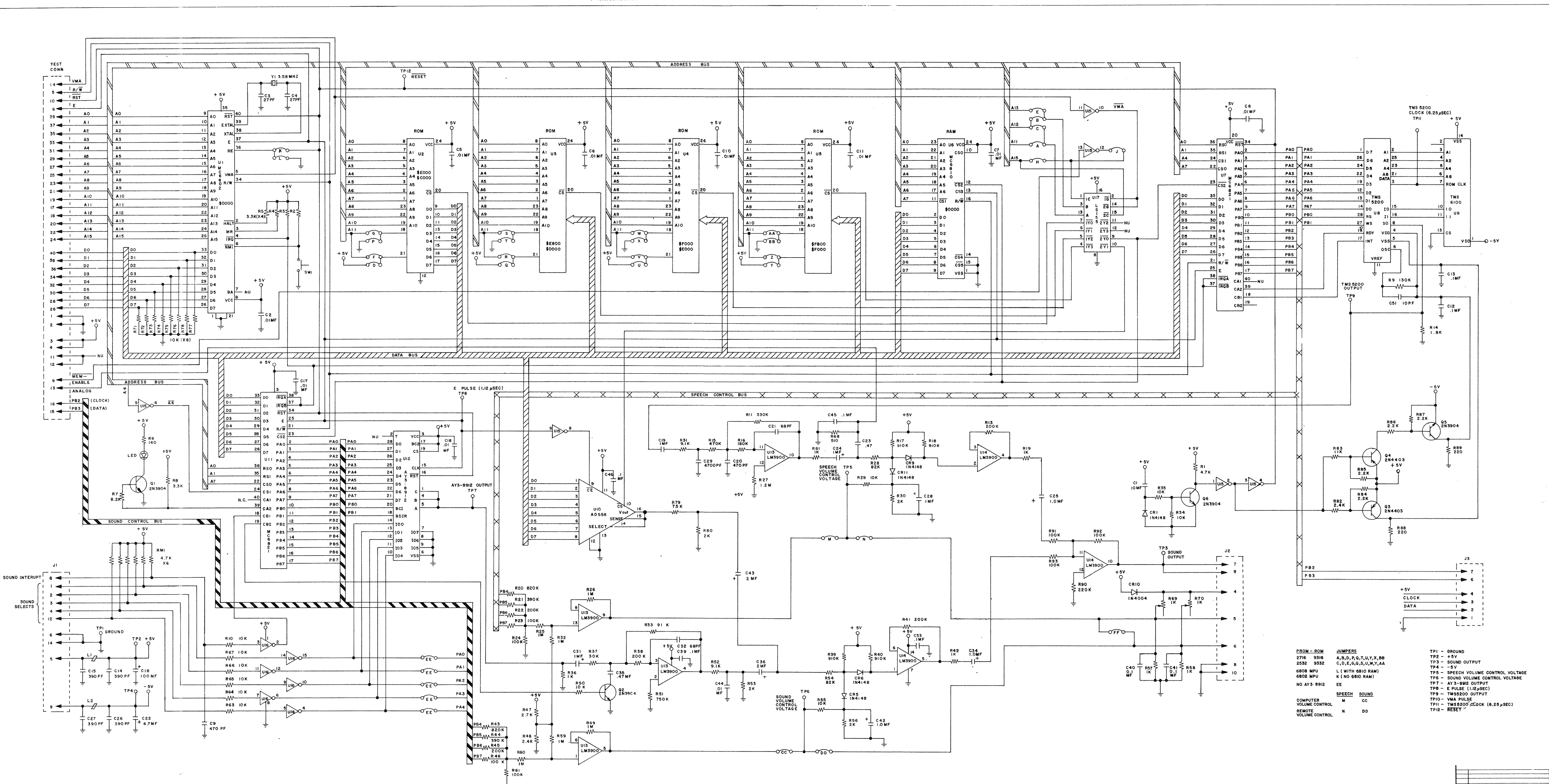

ROM - ROM JUMPER  
 2716 3016 A,B,D,P,Q,T,U,X,Y,AA  
 2532 9332 C,D,E,G,H,S,U,W,Y,AA  
 6808 MPU L (WITH 6810 RAM)  
 6802 MPU K (NO 6810 RAM)  
 NO AY3-8912 EE  
 COMPUTER SPEECH SOUND  
 VOLUME CONTROL M CC  
 REMOTE CONTROL N DD

TP1 - GROUND  
 TP2 - +5V  
 TP3 - SOUND OUTPUT  
 TP4 - -5V  
 TP5 - SPEECH VOLUME CONTROL VOLTAGE  
 TP6 - SOUND VOLUME CONTROL VOLTAGE  
 TP7 - SOUND VOLUME CONTROL VOLTAGE  
 TP8 - AY3-8912 OUTPUT  
 TP9 - PULSE (1.12µSEC)  
 TP10 - TMS2200 OUTPUT  
 TP11 - TMS2200 CLOCK (6.25µSEC)  
 TP12 - RESET

PROJECT END: B. KOWAN		REVISED ON		BY	
NO. OF SHEETS	1	NO. FULL	NO. REV. I PER	MIDWAY MFG. CO.	
DATE	10/24/84	DATE	10/24/84	PROJECT NO.	AD80-91600-000
DESIGNED BY	B. KOWAN	CHECKED BY	B. KOWAN	PART NO.	MOSI-00986-0037



DESIGNATION LIST

DESIGNATION	DESCRIPTION	DESIGNATION	DESCRIPTION
C101	.01 MF AX CER	IC 1D	7420
C301-C308	100 PF AX CER	IC 2D	93479
CP1-CP71	.01 MF AX CER	IC 3D	93479
CP72, CP86	100 MF AX ELECT.	IC 4D	7420
CP73-CP85, CP87,	10 MF 25V AX TANT.	IC 5D	93479
CP88		IC 6D	93479
CP89, CP90, CP91	.01MF AX. CER.	IC 7D	93422
		IC 8D	93422
		IC 9D	93422
R101-R111, R113-	1K OHM 1/4W	IC 10D	93422
R121		IC 12D	93422
R122, R123	560 OHM 1/4W	IC 13D	74LS245
R200	100 OHM 1/4W	IC 1E	74LS374
R201, R202	82 OHM 1/4W	IC 2E	74LS374
R203	1K OHM 1/4W	IC 3E	74LS374
RM1	82 OHM 8 PIN SIP	IC 4E	74LS374
RM 2	1K 10 PIN SIP	IC 5E	74LS374
RM 3	1K 10 PIN SIP	IC 6E	74LS374
RM 4	1K 9 PIN SIP	IC 7E	74LS240
RM 5	1K 9 PIN SIP	IC 8E	74LS00
RM 6	1K 9 PIN SIP	IC 9E	74S161
RM 7	1K 9 PIN SIP	IC 10E	74S04
IC 1A	EPROM	IC 1F	74LS74
IC 2A	EPROM	IC 2F	74LS74
IC 3A	EPROM	IC 3F	74LS157
IC 4A	EPROM	IC 4F	74S00
IC 5A	EPROM	IC 5F	74LS32
IC 6A	EPROM	IC 7F	74LS283
IC 7A	EPROM	IC 8F	74LS175
IC 8A	EPROM	IC 9F	74LS157
IC 9A	74LS86	IC 10F	74LS157
IC 10A	74LS86	IC 12F	74LS157
IC 11A	74LS174	IC 13F	74LS157
IC 12A	74LS273	IC 1G	74LS74
IC 13A	74S04	IC 3G	74S08
		IC 4G	74LS30
		IC 5G	74LS30
IC 1B	74LS194	IC 7G	74LS283
IC 2B	74LS194	IC 8G	74LS174
IC 3B	74LS194	IC 9G	74LS10
IC 4B	74LS194	IC 10G	74LS157
IC 5B	74LS194	IC 12G	74LS157
IC 6B	74LS194	IC 13G	74LS157
IC 7B	74LS194	IC 1H	74LS32
IC 8B	74LS194	IC 2H	74S86
IC 9B	74LS161	IC 3H	74LS240
IC 10B	74LS174	IC 11H	7420
IC 11B	74LS174	IC 12H	7420
IC 12B	74S283	IC 13H	74LS74
IC 13B	74S283		
IC 1C	74LS258	IC S1A-ICS8A	28 PIN SOCKET
IC 2C	74LS258	ICS D2, D3, D5-D10	22 PIN SOCKET
IC 3C	74LS258	ICS D12	24 PIN SOCKET
IC 4C	74LS258		
IC 5C	74LS00		
IC 6C	74LS04	J5, J6, J7	KK100 RT. ANGLE 24 PIN CONN.
IC 7C	74LS74		
IC 8C	74LS30		
IC 9C	74LS169	JW 1, JW2	JUMPER WIRE
IC 10C	74LS169		
IC 11C	74LS169	MCR III SUPER VIDEO GEN.	A082-91464-L000
IC 12C	74LS169		
IC 13C	74S133		

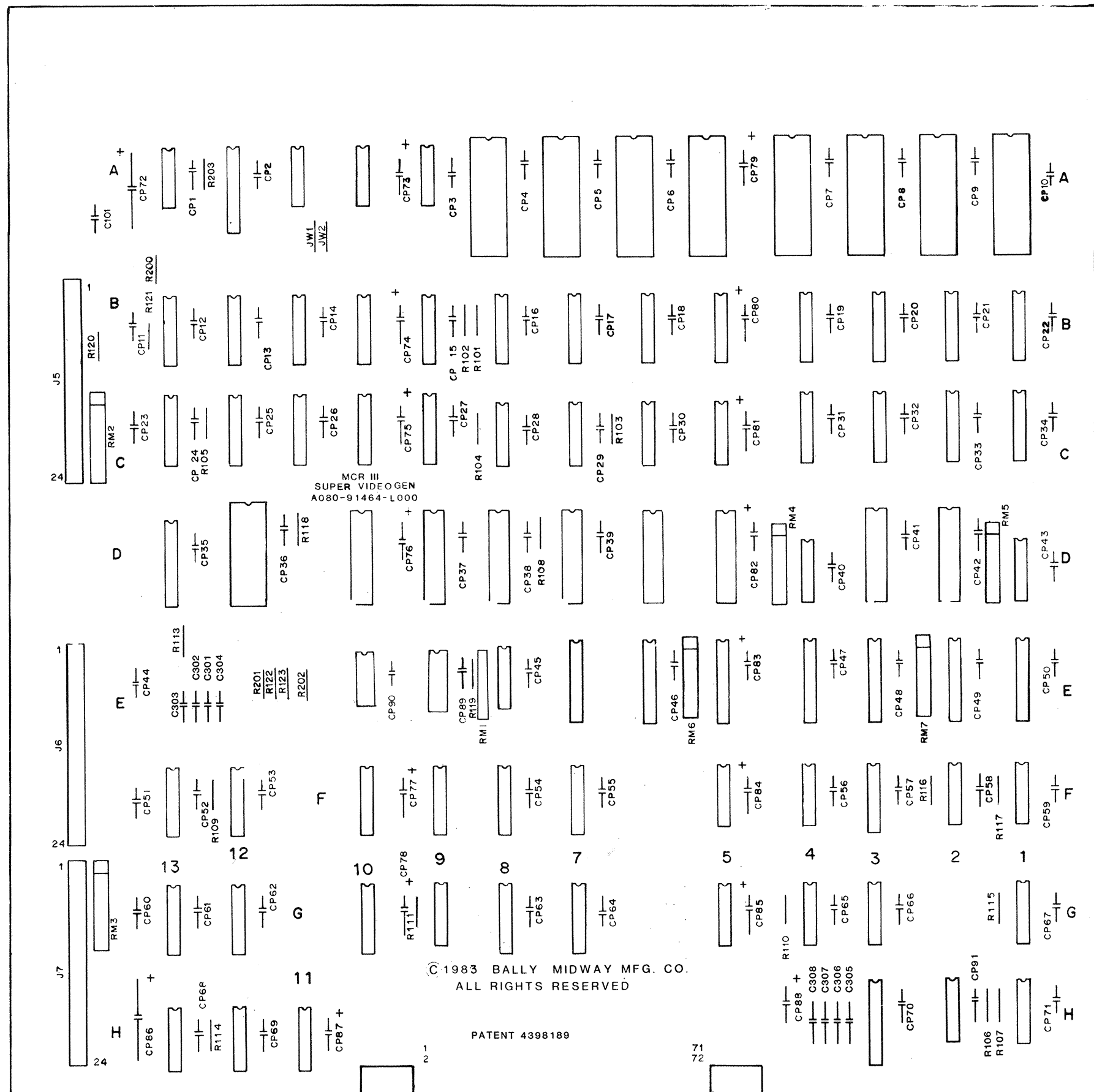

© 1983 BALLY MIDWAY MFG. CO.  
ALL RIGHTS RESERVED

PATENT 4398189

CROSS REFERENCE LIST

DESCRIPTION	QTY	DESIGNATION NO.	PART NOS.
CAP 100PF	8	C301-C308	0986-00800-1000
CAP .01MF	75	C101, CP1-CP71,	0986-00800-2500
		CP89, CP90, CP91	
CAP 10MF	15	CP73-CP85, CP87,	0986-00800-2400
		CP88	
CAP 100MF	2	CP72, CP86	0986-00800-1800
82 OHM 1/4 W RES.	2	R201, R202	100E-00005-0031
100 OHM 1/4 W RES.	1	R203	100E-00005-0033
1K OHM 1/4 W RES.	21	R101-R111, R113-	100E-00005-0061
		R121, R203	
560 OHM 1/4 W RES.	2	R122, R123	100E-00005-0054
8 PIN SIP	82 OHM	RM1	102E-00004-0035
9 PIN SIP	1K OHM	RM4-RM7	102E-00004-0011
10 PIN SIP	1K OHM	RM2, RM3	102E-00004-0013
74S00	1	4F	0304-00803-0047
74LS00	2	5C, 8E	0304-00803-0010
74S04	2	13A, 10E	0304-00803-0011
74LS04	1	6C	0304-00803-0012
74LS10	1	3G	0304-00803-0037
74LS10	1	9G	0304-00803-0014
7420	4	10, 4D, 11H, 12H	0304-00803-0015
74LS30	3	8C, 4G, 5G	0304-00803-0016
74LS32	2	5F, 1H	0304-00803-0017
74LS74	5	7C, 1F, 2F, 1G, 13H	0304-00803-0018
74S86	1	2H	0304-00803-0049
74LS86	2	9A, 10A	0304-00803-0019
74S133	1	13C	0304-00803-0020
74LS157	8	3F, 9F, 10F, 12F, 13F,	0304-00803-0021
		10G, 12G, 13G	
74S161	1	9E	0304-00803-0038
74LS161	1	9B	0304-00803-0022
74LS169	4	9C-12C	0304-00803-0023
74LS174	4	11A, 10B, 11B, 8G	0304-00803-0024
74LS175	1	8F	0304-00803-0025
74LS194	8	1B-8B	0304-00803-0026
74LS240	2	7E, 3H	0304-00803-0050
74LS245	1	13D	0304-00803-0027
74LS258	4	1C-4C,	0304-00803-0028
74LS273	1	12A	0304-00803-0029
74S283	2	12B, 13B	0304-00803-0039
74LS283	2	7F, 7G	0304-00803-0030
74LS374	6	1E-6E	0304-00803-0031
93422	4	7D-10D	0304-00803-0032
93479	4	2D, 3D, 5D, 6D	0304-00803-0033
STAT. RAM	1	12D	0304-00803-0034
EPROM KIT	8	IC1A-8A	SEE NOTE
28 PIN SOCKET	8	ICS 1A-8A	0986-00804-0300
22 PIN SOCKET	8	ICS 2D, 3D, 5D, 6D,	0986-00804-0700
		7D-10D	
24 PIN SOCKET	1	ICS 12D	0986-00804-1600
KK100 RT. ANGLE	3	J5, J6, J7	0986-00804-4700
24 PIN CONN.			
JUMPER WIRE	2	JW1, JW2	0986-00805-0200
MCR III SUPER VIDEO GEN.			A082-91464-L000

NOTE: ROM PART NUMBERS  
AT BACK OF CATALOG.

PROJECT ENG: R. PLOUSSARD		USED ON		REVISIONS	
DO NOT SCALE DWG.		HEAT TREAT	SCALE	FULL NO. REQ'D 1 PER	
DIM. TOLERANCES UNLESS SPECIFIED		MAT'L.	SUPER VIDEO GEN. MCR III		
CONCENTRICITY ± .003		FINISH	ASSY DWG		
FRACTIONAL ± .004			A082-91464-L000		
DECIMAL ± .002		DATE 12/19/83	PART NO. M051-00304-L005		
HOLE DIA ± .002					





DESIGNATION LIST

DESIGNATION NO.	DESCRIPTION
C1,C2	4.7 MF 25V RD TANT.
C3,C4	22 MF 6V RD TANT.
C5,C6	470 MF 6V AX ELECT.
C7-C10	.1 MF 50V AX CR.
C11-C14	4.7 MF 25V RD TANT
CP1	220 MF 25V AX ELECT.
CP2,CP3	.1 MF 50V AX CR.
R1,R2	2.7K OHM 1/4W 5% CRBN.
R3,R4	27 OHM 1/4W 5% CRBN.
R5-R8	1 OHM 1/2W 5% CRBN.
R9,R10	2.7K OHM 1/4W 5%
U1,U2	MB3730
J1	.045 SQ. PIN
J2	.045 SQ. PIN
HSU1,U2	HEATSINK ASSY
MH1-MH4	1/4" SPACER FOR #8 SCREW
DUAL PWR AMP W/MXR	A080-91648-A000

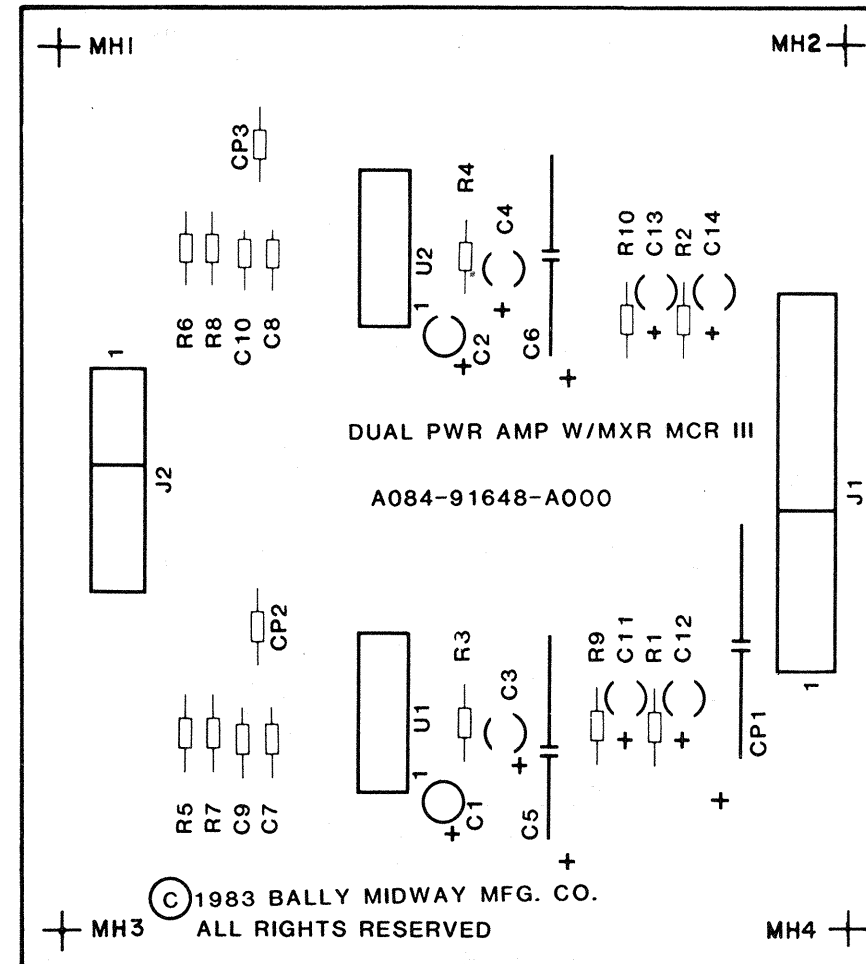

CROSS REFERENCE LIST

DESCRIPTION	QTY	DESIGNATION NO.	PART NOS.
.1 MF 50V AX CR.	6	C7-C10,CP2,CP3	0986-00800-1100
4.7 MF 25V RD TANT.	6	C1,C2,C11-C14	0986-00800-3100
22 MF 6V RD TANT	2	C3,C4	0986-00800-1600
220 MF 25V AX ELECT.	1	CP1	0986-00800-3200
470 MF 6V AX ELECT.	2	C5,C6	0986-00800-1700
1 OHM 1/2W 5%	4	R5-R8	0062-02603-1XXX
27 OHM 1/4W 5%	2	R3,R4	0062-068B3-1XXX
2.7K 1/4W 5%	4	R1,R2,R9,R10	0062-199B3-1XXX
MB3730	2	U1,U2	0066-188XX-XX4X
.045 SQ. PIN	5	J2	0017-00033-0480
.045 SQ. PIN	10	J1	0017-00033-0480
HEATSINK ASSY	2	HSU1,HSU2	A986-00010-0000
1/4" SPACER FOR #8 SCREW	4	MH1-MH4	0017-00042-0320
DUAL PWR AMP W/MXR	1		A080-91648-A000

REVISIONS	

PROJECT ENG: C. MEDNICK		USED ON MCR III		Bally / MIDWAY MFG. CO. FRANKLIN PK. ILL.	
DO NOT SCALE DWG.		HEAT TREAT	SCALE FULL	NO. REQ'D 1 PER	
DIM TOLERANCES UNLESS SPECIFIED		DRN. RLW	MAT'L.	ASSEMBLY DWG.	
CONVERTIBILITY TO FACTORY		CKD.	FINISH	DUAL POWER AMP W/MIXER MCR III	
DECIMAL		DATE 07/05/83		PART NO. M051 - 00304 - A012	
HOLE DIA + .002 000				A080-91648-A000	

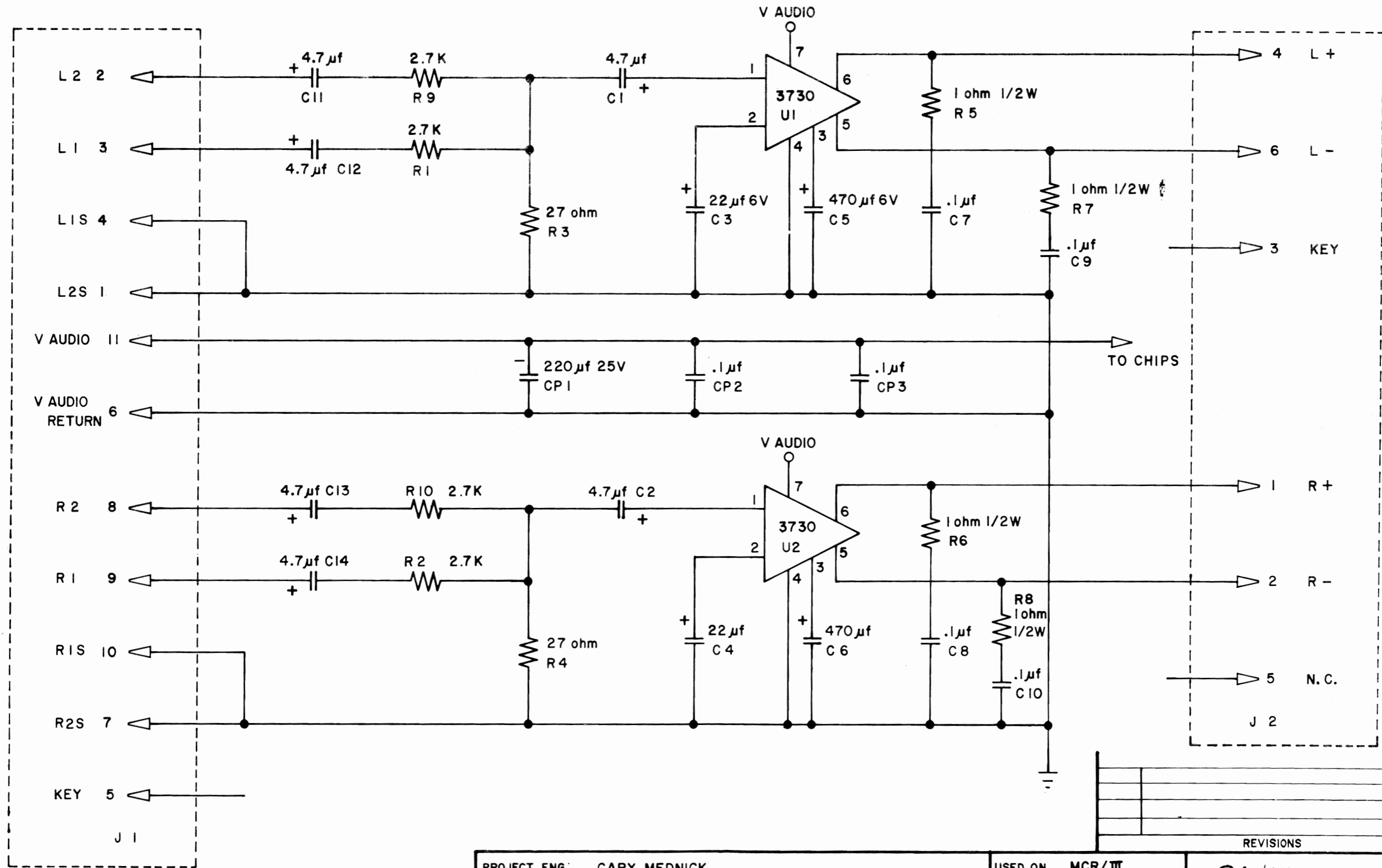

REVISIONS	

PROJECT ENG: CARY MEDNICK		USED ON MCR/III		<i>Bally</i> / MIDWAY MFG. CO. FRANKLIN PK ILL
DO NOT SCALE DWG		HEAT TREAT	SCALE	
DIM TOLERANCES UNLESS SPECIFIED		NO. REQ'D   PER		PART NO. M051 - 00304 - A013
CONCENTRICITY TYP. .005	DRM. / L L	SHEMATIC DRAWING		
FRACTIONAL .164	CKD.	DUAL PWR AMP W/MXR MCR III		
DECIMAL .005	DATE 6/30/83	A084-91648-A000		
HOLE DIA. + .002 .000				

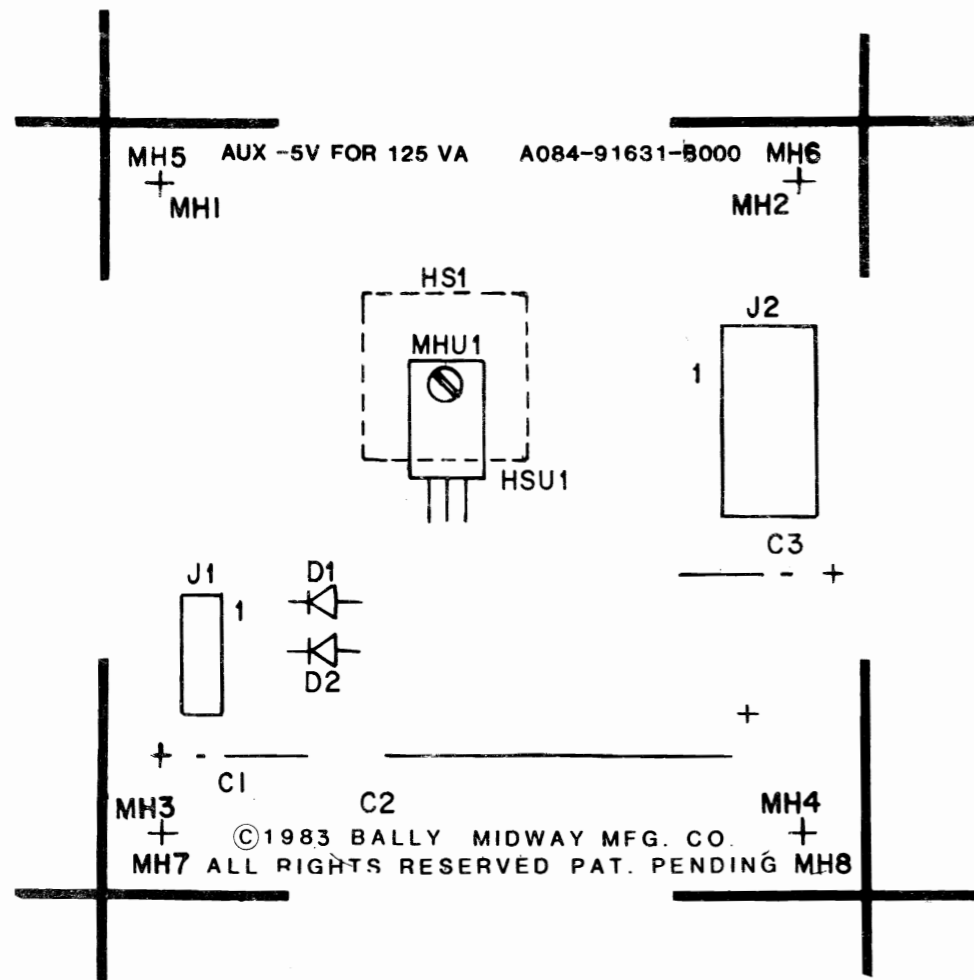

DESIGNATION LIST

DESIGNATION NO.	DESCRIPTION
C1	2.2 MF TANT.
C2	2200 MF 25V ELECT.
C3	.1 MF CER.
D1, D2	1N4004 DIODE
HSU1	79M05 VOLTAGE REGULATOR
HS1	HEATSINK, CLIP ON
MHU1	(1) SCREW (1) NUT (1) WASHER
J1	KK156 4 PIN CONN.
J2	AMPHENOL 3 PIN CONNECTOR
MH1-4	SPACER
A080-91631-B000	AUX.-5V FOR 125VA P.C. BOARD

CROSS REFERENCE LIST

DESCRIPTION	QTY	DESIGNATION NO.	PART NOS.
0.1 MF CER.	1	C3	0945-00816-1905
2.2 MF TANT.	1	C1	0945-00816-1904
2200 MF ELECT.	1	C2	0945-00816-1903
1N4004 DIODE	2	D1, D2	0636-00801-0300
79M05 VOLTAGE REGULATOR	1	HSU1	0945-00813-0601
HEATSINK, CLIP ON	1	HS1	0068-065XX-ABAX
SCREW	1	MHU1	0017-00101-0518
NUT	1		0017-00103-0003
WASHER	1		0017-00104-0003
KK156 4 PIN CONN. OMIT PIN 3	3	J1	0017-00033-0480
AMPHENOL 3 PIN CONNECTOR	1	J2	0017-00021-0443
SPACER	4	MH1-MH4	0017-00042-0328
AUX.-5V FOR 125VA P.C. BOARD	1		A080-91631-B000

REVISIONS	USED ON PROF. PAC.		NO. REQ'D 1 PER		SCALE FULL		HEAT TREAT		MATERIAL		FINISH	
	MIDWAY MFG. CO.		FRANKLIN PK. ILL.		ASSEMBLY DWG.		AUX. -5V FOR 125VA		A084 - 91631 - B000		DATE 05/18/83	
PART NO.			M051 - 00114 - A074			PROJECT ENG: J. JARON						
DO NOT SCALE DWG.												
DIM. TOLERANCES UNLESS SPECIFIED												
CONCENTRICITY ± .005												
DECIMAL ± .002												
HOLE DIA ± .002												

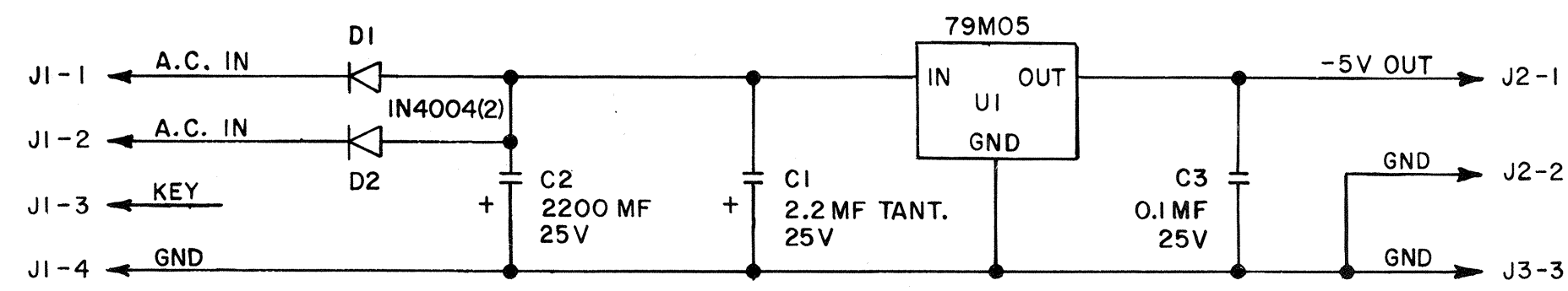

PROJECT ENG: J. JARON		USED ON PROF. PAC		REVISIONS	
DO NOT SCALE DWG.		HEAT TREAT	SCALE FULL	NO. REQ'D 1 PER	
DIM TOLERANCES UNLESS SPECIFIED		MAT'L.	SCHEMATIC DWG.		PART NO. M051 - 00114 - A075
DATE 05/18/83		FINISH	AUX -5V FOR I25VA A084 - 91631 - B000		

*Bally* / MIDWAY MFG. CO.  
FRANKLIN PK. ILL.

DESIGNATION LIST

DESIGNATION #	DESCRIPTION	DESIGNATION #	DESCRIPTION
C101	4700uf AX. ELECT.		
C102	470uf AX. ELECT.		
C103	.1uf AX. CER.	D101	A15F
C104	.1uf AX. CER.	D102	A15F
C105	47pf AX. CER.	D103	A15F
C106	470uf AX. ELECT.	D104	A15F
C107	100uf RD. TANT.	D105	A15F
C108	1uf RD. TANT.	D106	1N4001
C109	4.7uf RD. TANT.	D201	1N4148
C110	.1uf AX. CER.	D202	1N4148
C111	.1uf AX. CER.	D203	1N4148
C201	.01uf MYLAR	D204	1N4001
C202	.033uf MYLAR	D205	1N4001
C203	.01uf MYLAR		
C204	.047uf MYLAR		
C205	820pf AX. CER.		
C206	.01uf AX. CER.		
C207	0.082uf MYLAR		
		Q102	2N2905
		Q105	2N2905
		Q201	2N4401
CP1	.1uf AX. CER.	U1	LM305 REG.
		U2	LM305 REG.
		U3	LM3900
		U4	4N28
		U6	555
R101	.18ohm 5W W/RES. SPACER		
R102	68ohm 1/2W 5%		
R104	10ohm 5W W/RES. SPACER	L101	22uH INDUCTOR
R105	27ohm 1/4W 5%		
R106	270ohm 1/4W 5%	B101	BATTERY 3.6VDC 60DEG-C
R107	6.2K 1/4W 5%		
		F1	3 BA S BLO FUSE
R109	1K 1/4W 5%		
R110	.16ohm 15W W/RES. SPACER	FC1A,1B	FUSE CLIP
R111	6.8ohm 1/2W 5%		
R112	68ohm 1/2W 5%	FE1,2	FERRITE BEAD
R113	1.2K 1/4W 5%		
R114	47ohm 1/4W 5%	TW1	TIE WRAP
R115	160ohm 1/4W 5%		
		J3	9PIN P.C. MOUNT CONN.(MALE)
		J4	15PIN P.C. MOUNT CONN.(FEMALE)
		J5	15PIN P.C. MOUNT CONN.(MALE)
		J6	3PIN P.C. MOUNT CONN.(MALE)
		LB1	FUSE TAG
		LB2	SYSTEM TAG
		HSA1	HEAT SINK ASS'Y 1
		MHSA1	MOUNTING HARD WARE(HEAT SINK)
			2 SCREW
			4 WASHER
			2 HEXNUT
		JW1-5	JUMPER WIRE
		FBMH1,2	FERRITE BEAD MOUNTING HARDWARE
VR101,102	100ohm POT		

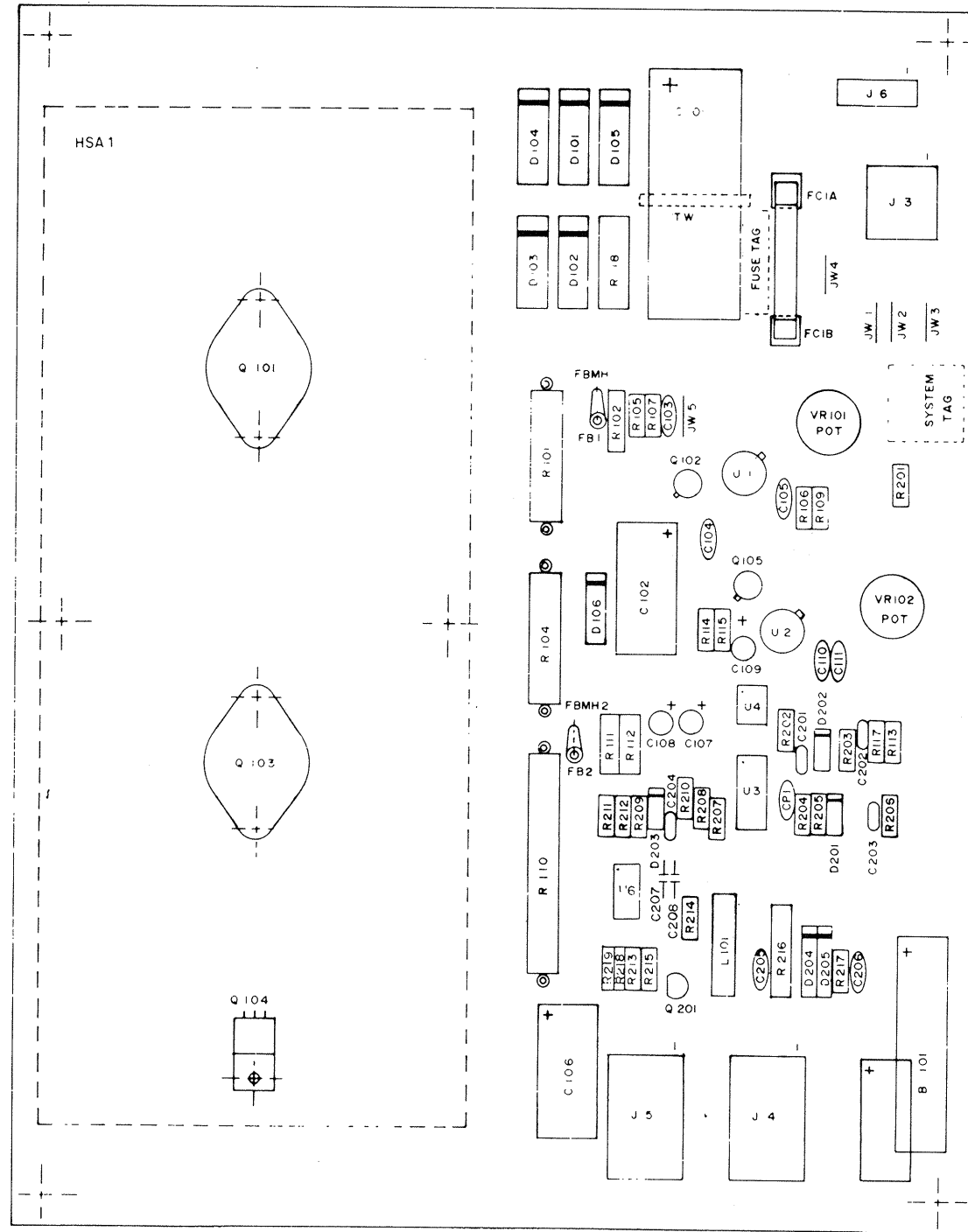

DESCRIPTION	Q'ty	DESIGNATION #	PART #
47pf AX. CER.	1	C105	0945-00811-0100
820pf AX. CER.	1	C205	0945-00816-0400
.01uf AX. CER.	2	C206,208	0945-00816-0100
.01uf MYLAR	2	C201,203	0945-00316-0200
.033uf MYLAR	1	C202	0945-00816-0500
.047uf MYLAR	1	C204	0945-00816-0300
0.082uf AX. CER.	1	C207	0945-00816-1900
.1uf AX. CER.	5	C103,104,110,111,CP1	0945-00811-0200
1uf RAD. TANT.	1	C108	0945-00811-0300
4.7uf RAD. TANT.	1	C109	0945-00811-0400
100uf HAD. TANT.	1	C107	0945-00811-0500
470uf AX. ELECT.	2	C102,106	0945-00816-0600
470uf AX. ELECT.	1	C101	0945-00811-0700
.16ohm 15W 5%	1	R110	0945-00815-0100
.18ohm 5W 5%	1	R101	0945-00815-0200
6.8ohm 1/2W 5%	1	R111	0062-04703-1XXX
10ohm 5W 5%	1	R104	0945-00812-0100
27ohm 1/4W 5%	1	R105	0062-068B3-1XXX
47ohm 1/4W 5%	1	R114	0062-086B3-1XXX
68ohm 1/2W 5%	3	R102,112,219	0062-098D3-1XXX
82ohm 1W 10%	1	R216	0062-104F5-1XXX
150ohm 2W 5%	1	R118	0945-00812-0200
160ohm 1/4W 5%	1	R115	0062-124B3-1XXX
270ohm 1/4W 5%	3	R106,201,217	0062-138B3-1XXX
560ohm 1/4W 5%	1	R117	0062-162B3-1XXX
1K 1/4W 5%	1	R109	0062-179B3-1XXX
1.2K 1/4W 5%	3	R113,202,215	0062-183B3-1XXX
3.9K 1/4W 5%	1	R214	0062-207B3-1XXX
6.2K 1/4W 5%	1	R107	0062-217B3-1XXX
33K 1/4W 5%	1	R207	0062-251B3-1XXX
75K 1/4W 5%	2	R211,212	0062-269B3-1XXX
100K 1/4W 5%	1	R206	0062-275B3-1XXX
110K 1/4W 5%	1	R218	0062-277B3-1XXX
220K 1/4W 5%	1	R213	0062-291B3-1XXX
1M 1/4W 5%	1	R209	0062-323B3-1XXX
1.1M 1/4W 5%	1	R203	0062-325B3-1XXX
1.2M 1/4W 5%	1	R210	0062-327B3-1XXX
2M 1/4W 5%	1	R209	0062-337B3-1XXX
3.3M 1/4W 5%	1	R204	0062-347B3-1XXX
10M 1/4W 5%	1	R205	0062-371B3-1XXX
100ohm POT	2	VR101,102	0945-00814-0000

CROSS REFERENCE LIST

DESCRIPTION	Q'ty	DESIGNATION #	PART #
LM305 REG.	2	U1,2	0945-00813-0100
555	1	U6	0929-00810-4500
LM3900	1	U3	0945-00813-0200
4N28	1	U4	0945-00813-0300
A15F RECTIFIER	5	D101-105	0945-00804-0200
1N4001	3	D106,204,205	0945-00804-0300
1N4148	3	D201-203	0945-00804-0500
2N2905	2	Q102,105	0945-00808-0300
2N4401	1	Q201	0945-00804-0400
BATTERY 3.6VDC 60DEG-C	1	B101	0017-00003-0377
FUSE 3/8A S-BLO	1	F1	0945-00808-0400
FUSE CLIP	2	FC1A,1B	0017-00003-0214
TIE WRAP	1	TW1	0945-00814-0300
FERRITE BEAD	2	FB1,2	0017-00009-0225
FERRITE MOUNTING HDW.	2	FBMH1,2	0017-00033-0139
22uH INDUCTOR	1	L101	0945-00814-0200
FUSE TAG	1		M051-00945-A004
SYSTEM TAG	1		M051-00945-A009
P.C.B.	1		A080-90412-U000
HEAT SINK ASS'Y	1	HSA1	A945-00008-0000
(SEE HS ASS'Y DRAWING "XX NOTE")			
4-40 X10 SLT RND	2	MH HSA 1A,2A	0017-00101-00727
4-40 HEX NUT	2	MH HSA 1E,2E	0017-00103-0002
WSH 4-120-.250-018	4	MH HSA 1B,1D	0017-00104-0071
		MH HSA 2B,2D	
3PIN P.C. MOUNT CONN. (MALE)	1	J6	0017-00021-0443
9PIN P.C. MOUNT CONN. (MALE)	1	J3	0017-00021-0425
15PIN P.C. MOUNT CONN. (FEMALE)	1	J4	0017-00021-0441
15PIN P.C. MOUNT CONN. (MALE)	1	J5	0017-00021-0440
22AWG T & R BARE 2.5"	5	JW1-5	0151-00087-0000

PROJ. ENG.: L. DEKKER		USED ON: SATAN'S HOLLOW		MIDWAY MFG. CO.	
NO. OF REV.	DATE	NO. OF REV.	DATE	NO. OF REV.	DATE
1	5/17/82	1		1	
ASSEMBLY DRAWING 125VA PWRSPY			PART NO. M051-00945-D006		
A082-90412-D000					

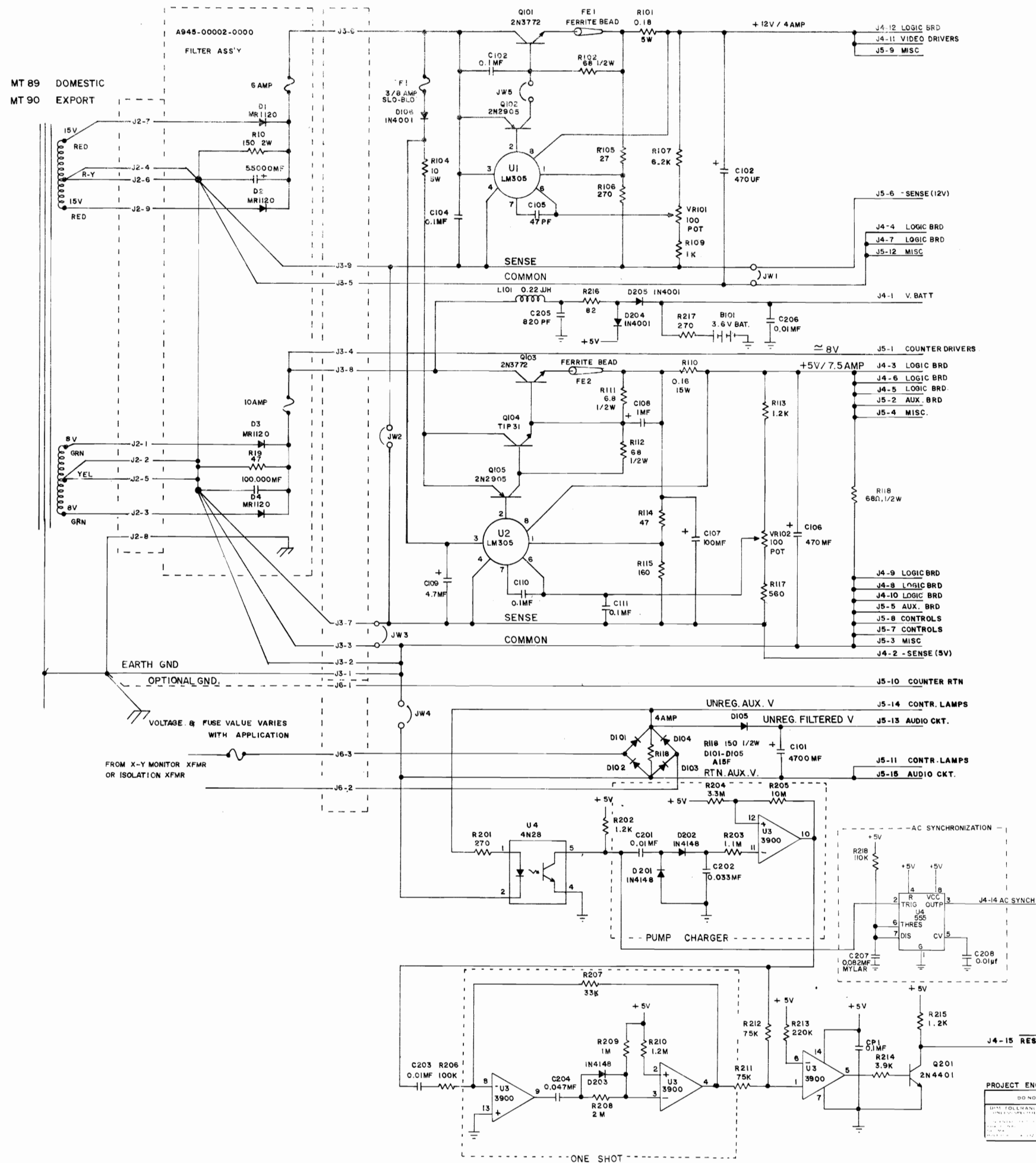

PROJECT ENG. L. DEKKER		SATEM FOLLOW		MIDWAY MFG. CO.	
DO NOT SCALE DWG		FULL		FRANKLIN PR. ILL.	
DATE	5/3/82	W/CKT SUPPORT	POWER SUPPLY 125VA		
5/3/82		A082-90412-0000		M051-00945-D007	